

## IMPORTANT SAFETY INSTRUCTIONS LED DOWNLIGHT INSTALLATION

**READ AND FOLLOW ALL SAFETY INSTRUCTIONS. SAVE THESE INSTRUCTIONS AND DELIVER THEM TO THE OWNER AFTER THE INSTALLATION IS FULLY COMPLETED**

- To reduce the risk of death, personal injury or property damage from fire, electric shock, falling components and cuts and abrasions please read all warnings and instructions included with and on the fixture box and attached product labels.
- Before installing, servicing, or performing any maintenance upon these products please follow these general precautions.
- As the LED components are all low voltage they do not require a qualified licensed electrician to install them. However a duly qualified licensed electrician will be required to install the GPO outlet into which the 3-point-plug that the LED Driver will be connected to.
- All wiring procedures to comply with Australian Wiring Rules AS/NZ3000
- Any maintenance should be performed by persons familiar with the LED light system's constructions. Regular maintenance is recommended.
- Regular Cleaning – It will be necessary to occasionally clean the outside of the lens. The frequency of cleaning will depend on the ambient dirt level based on the dustiness of the surrounding environment. A warm solution using a mild non-abrasive household detergent should be used. Then rinsed with clean water and wiped dry.
- These instructions do not purport to cover all details or to provide every possible contingency concerning, installation, operations and maintenance. Should any further information be required please contact Delta Panels Pty Ltd at [info@deltapanel.com](mailto:info@deltapanel.com)



### DO NOT INSTALL DAMAGED PRODUCT

- This lighting system has been pre-tested and packed properly so that no parts should be damaged during transit.
- Please inspect to confirm all parts are received in good working order.
- Any parts damaged or broken during or after assembly should be replaced.



### WARNING RISK OF ELECTRIC SHOCK

- Disconnect or turn off power before installation or servicing.
- Do not operate the LED driver if the light is not connected



## CAUTION RISK OF INJURY

- Wear the required PPE (Gloves & Safety Glasses) at all times when installing, servicing or performing maintenance.
- Avoid direct eye contact with the light when it is operating.



## WARNING RISK OF BURN

- Allow the light to cool before handling
- Do not touch the enclosure or light source
- Do not exceed the maximum wattage marked on the product's labels



## CAUTION RISK OF FIRE

- Keep combustible and other materials that can burn away from the lamp/lens
- If installing into the ceiling of an Delta Insulated Panel it's recommended to allow an airspace gap of 10mm from the back of the light to the Expanded Polystyrene Fire Retardant (EPS-FR) core. This is to allow for convection or conduction cooling
- The maximum operating temperature must not exceed 85°C, do not operate at a temperature higher than this.
- Be careful that no sharp edge is remaining after the cut-out cavity is made, especially if going into steel skinned panels.



## CAUTION RISK OF PRODUCT DAMAGE

- Never connect components under load.
- Do not mount or install any product in a manner that can cut the outer jacket or damage the wire insulation.
- If connecting to a dimmer ensure that the dimmer is compatible with the information specifically recommended for the LED lighting system.
- Do not install any component that has any visible damage to the cables or connectors.
- Never install the LED lighting system in places where they will be exposed to direct rain, high humidity, extreme temperature changes or restricted ventilation.
- There are no user serviceable parts inside the unit. Do not rewire, reconfigure or modify the unit in any way.

**FAILURE TO FOLLOW ANY OF THESE INSTRUCTIONS COULD VOID THE PRODUCT WARRANTY**

## PRODUCT COMPONENTS

### DLP120 Light set consists of:-

- 2 x DeltaLowProfile Recess Light
- 2 x 6 metre lead
- 2 x 3 metre extension lead
- 2 x Trimac dimmable drivers with 1 metre power connection lead

### DLP170 Light set consists of:-

- 1 x DeltaLowProfile Recess Light
- 1 x 6 metre lead
- 1 x 3 metre extension lead
- 1 x Trimac dimmable driver with 1 metre power connection lead



## PRODUCT SPECIFICATION

### DELTALOWPROFILE™ VOLTAGE DRIVER SPECIFICATIONS

		DLDR12 - Trimac Dimmer	
INPUT VOLTAGE	200-240 VAC, 47-63Hz		
OUTPUT VOLTAGE	DLP120	18-25 VDC, 300mA +/-10mA	
	DLP170	30-45 VDC, 300mA +/-10mA	
Finish	Aluminium Weatherproof Case		
Dimmable Range	Down to 10%		
WARRANTY	3 year limited warranty		

## PRODUCT DIMENSIONS

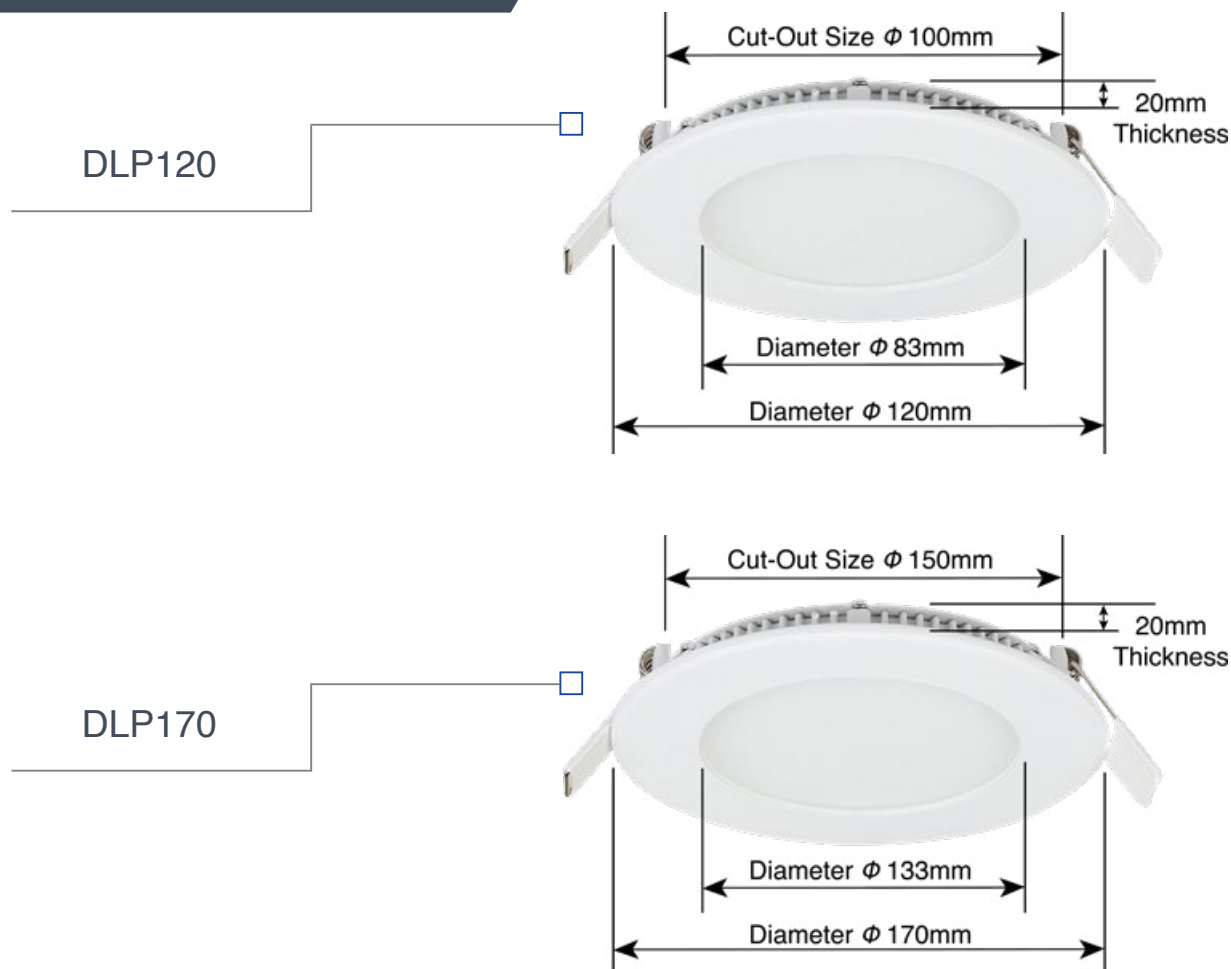

## RECOMMENDED INSTALLATION STEPS INTO AN INSULATED STRUCTURAL PANEL

### STEP 1 - DETERMINE THE WIRING LAYOUT

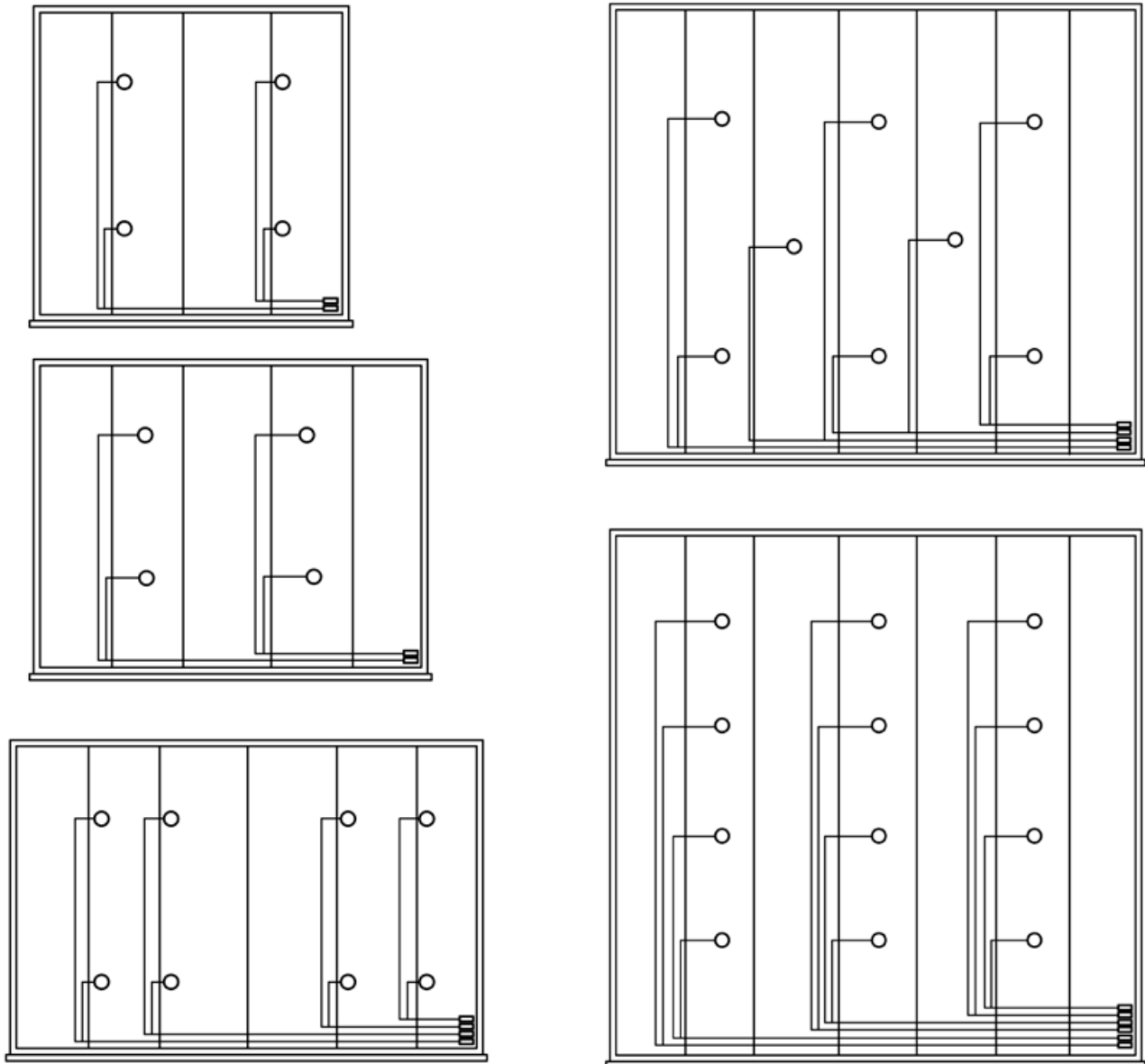

### STEP 2 - ENSURE POWER IS DISCONNECTED

- Ensure that there is no live power in the work area, especially where the recess holes are going to be cut.
- Make sure that the power supply is switched off to the GPO which will power the Led Driver.

## STEP 3 - CUT OUT THE REQUIRED CEILING HOLE

- Refer to the template size on the product information provided.
- Prior to cutting the hole, double check that the size for the product you are going to install.
- Remove all insulation in the hole area to a depth of 30mm
- Remove all insulation from where the light will sit to ensure there is a 10mm air flow gap from the edge of the light fitting.
- Ensure that this discarded insulation is collected and properly disposed of.

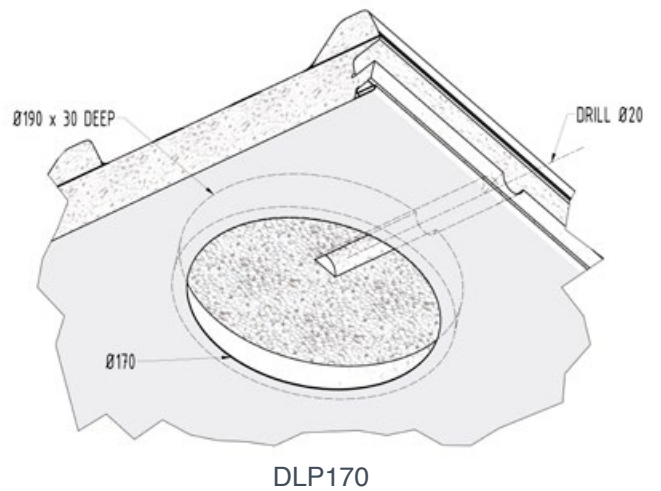
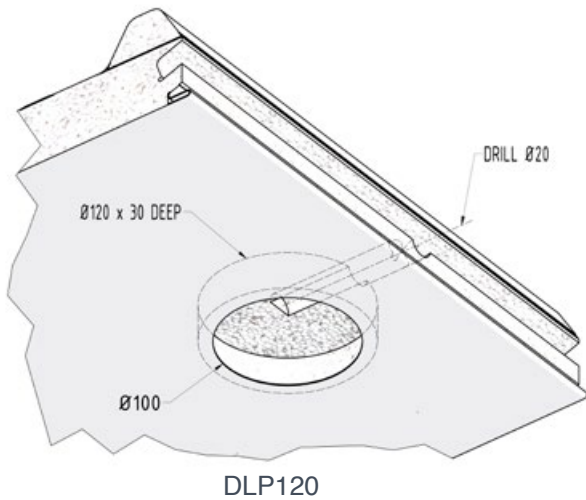

## STEP 4 - Drill Cable Slots

- A 20mm hole is required to be drilled through the EPS core from the edge of the panel to the recessed light hole.
- The insulated cable is fed through this hole.

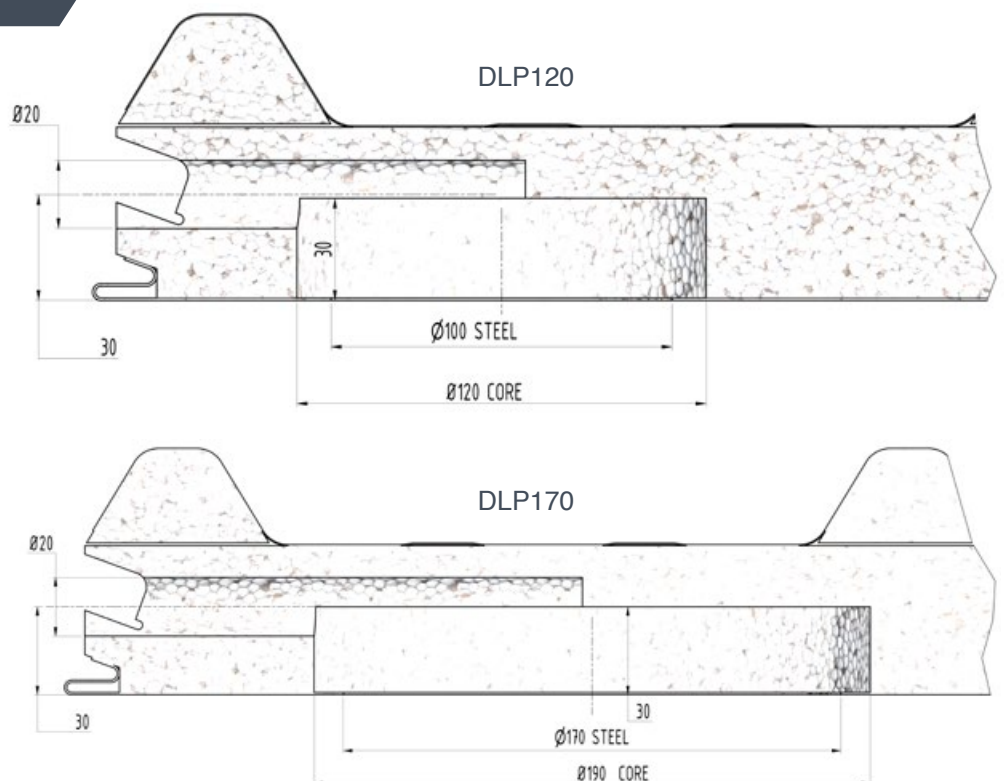

## STEP 5 - MOUNT THE LED DRIVER

- Mount the LED driver at the fixing points on the back of the product case.
- It's recommended that the LED driver is mounted in the roof cavity in an easy to access location.
- For a Stand Alone structure where it is not possible to mount the LED driver in the roof cavity it is recommended to place the device behind the rear barge capping.

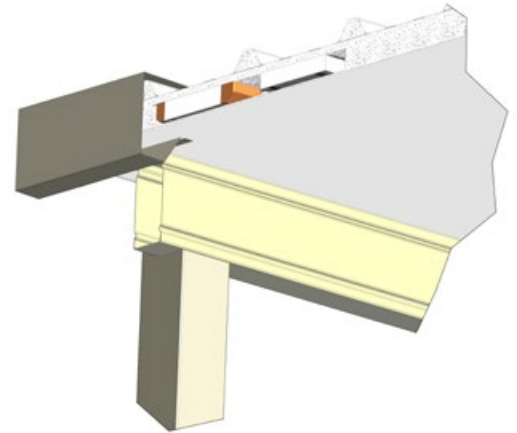

STAND ALONE MOUNTING OF LED DRIVER

## STEP 6 - DETERMINE THE REQUIRED CABLE LENGTH

- Measure the distance from the position of the LED light to the LED driver and determined the length of cable required.
- The LED Light assembly comes with a both 6 metre and a 3 metre cable and can be configured to reach 9 metres.



## STEP 7 - CONNECT CABLE TO THE LED DRIVER

- Once the required cable length is determined and the cable combination is created, attach the cable to the LED driver by the Thread-Lock Cable Joiner.



## STEP 8 - RUN THE CABLE AND CONNECT TO THE LIGHT

- After connecting the cable to the LED Driver run the cable along the cable recess track on the edge of the Panel.
- Make a track from the cable recess track to the light cut-out recess and then pull the cable through to the cut-out recess
- Connect the light and the cable by the Thread-Lock Cable Joiner.



## STEP 9 - MOUNT THE LED LIGHT FIXTURE

- Mount the spring on the back of the light, be careful not place your hands underneath the spring clips to avoid any hand injuries.
- Ensure that the light is correctly seated in the recess, that the spring clips are fully engaged and are securely holding the LED light.



## STEP 10 - CONNECT THE LED DRIVER TO MAINS POWER

- Turn on the mains power to the GPO that the 3-prong-plug for the LED driver will be connected to.
- Plug the power lead into the GPO.

## STEP 11 - TURN ON THE LED LIGHT

- Turn on the power to the LED light.



## TROUBLE SHOOTING

- If the light does not turn on within 5 seconds, or if the light is functioning irregularly turn off the power source.
- Carefully remove the LED light and double check all connections and wiring.
- Replace individual components to isolate any faulty part.
- Have a qualified licensed electrician verify that the line voltage is correct.
- Should any further information be required please contact Delta Panels Pty Ltd at [info@deltapanel.com](mailto:info@deltapanel.com)



## WARNINGS

- Do not use any other driver except the one provided as part of the LED Lighting kit.
- Do not connect multiple LED light modules to a single driver.
- Do not open the LED Light Module or the LED Driver Module. There are no serviceable parts inside.
- Do not change parts or perform any modifications on any parts of the LED light fixture kit.
- Do not operate the LED driver if the LED light is not connected.

**FAILURE TO FOLLOW ANY OF THESE INSTRUCTIONS COULD VOID THE PRODUCT WARRANTY**