

# 3CH 12-36V 6A Constant Voltage Power Repeater



## Summary

- Used with various LED PWM constant voltage controller, expand output power of the controller to control more lamps.
- A controller can connect unlimited number of LED power repeaters in series or in parallel, and achieve the synchronous control effects.

## Technical Parameters

- Input voltage: 12-36VDC
- Load current: 3CH, 6A/CH
- Output power: 3 x (72-216)W
- Working temperature: -30°C~55°C
- Product size: L175×W45×H27mm
- Net weight: 110g

## Dimension

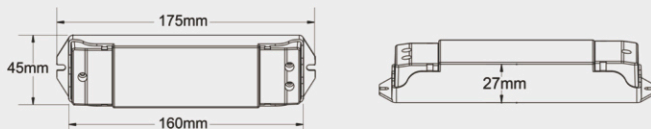

## Interface Specification



## Wiring Diagram

### • Series connection

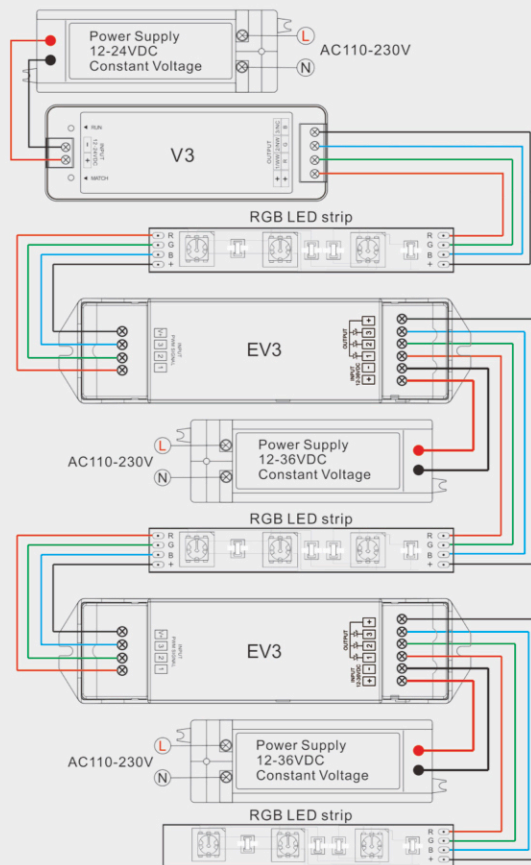

### Parallel connection

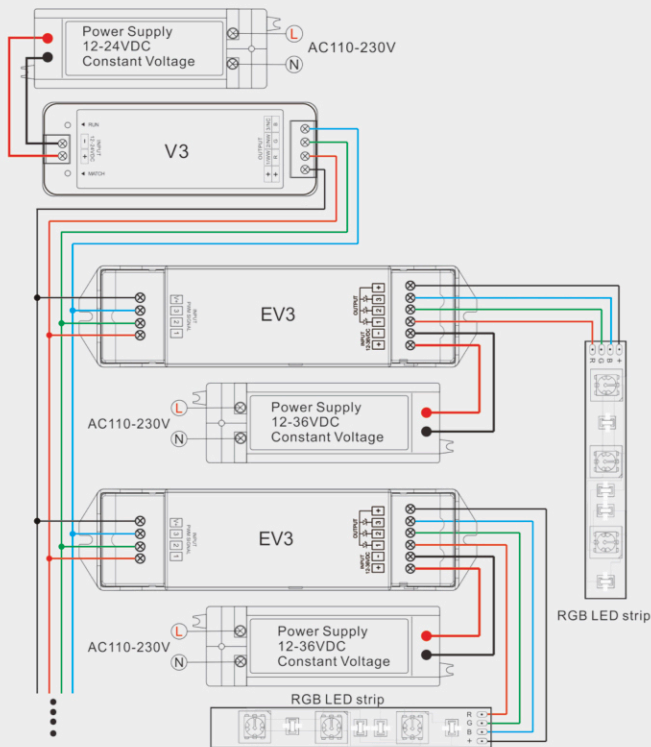

#### LED power supply voltage and power select :

12V lamp, Input 12V power supply, can load 0~216W,

24V lamp, Input 24V power supply, can load 0~432W,

36V lamp, Input 36V power supply, can load 0~648W,

The power supply power must larger than load power 20%.

### Malfunctions analysis & troubleshooting

Malfunctions	Causes	Troubleshooting
No light	1. No power. 2. Wrong connection or insecure.	1. Check the power. 2. Check the connection.
Wrong color	1. Wrong connection.	1. Reconnect wires.
Uneven intensity between front and rear, with voltage drop	1. Output cable is too long. 2. Wire diameter is too small. 3. Overload beyond power supply capability. 4. Overload beyond controller capability.	1. Reduce cable or loop supply. 2. Change wider wire. 3. Replace higher power supply. 4. Add power repeater.

### Safety & Warnings

1. The product shall be installed and serviced by a qualified person.
2. This product is non-waterproof. Please avoid the sun and rain.
3. Good heat dissipation will prolong the working life of the controller, Please ensure good ventilation.
4. Please check if the output voltage of any power supplies used comply with the working voltage of the product.
5. Ensure all wire connections and polarities are correct and secure before applying power to avoid any damages to the LED lights.
6. If a fault occurs please return the product to your supplier. Do not attempt to fix this product by yourself.

### Warranty Agreement

#### 1. 5-year warranty:

- The warranty is for free repair or replacement and covers manufacturing faults only.
- Do not include fees of on site maintenance and consumable parts.

#### 2. Limited Warranty

- Artificial damage caused by improper use, such as use inappropriate power supply, improper accessories, improper installation, did not follow the instructions, error using or negligence.
- Any damages caused by force majeure, such as natural disaster, abnormal voltage.
- The normal use of products caused by aging, wear and tear, but it does not affect the normal use.