



HANDLING & INSTALLATION MANUAL

DELTA PANELS™ ROOFING SYSTEMS

- *Delta Trim™*
- *Delta Orb™*
- *Delta CorroCorro™*
- *Delta Trim Trim™*
- *Delta Trim Corro™*



DELTATM PANELS



CONTENTS

1	Introduction	4
2	Delta Panel Profiles	5
3	Safety.....	10
4	Tools & Equipment	11
5	Delivery Receipts & Storage	12
6	Handling of the Panels	14
7	Framing Alignment	16
8	Installation - Panel Preparation	17
9	Installation - Panel Cutting	19
10	Installation - Cleaning	20
11	Installation - Touch-up	20
12	Installation - Fasteners, Flashings, Foam Infills Strips and Sealants	21
13	Installation - Panel Layout	24
14	Installation - Connection Details	31
15	Installation - Flashings	43
16	Installation - Services & Accessories	105
17	Reference Library	114

1. INTRODUCTION

This manual should be used as a general guide only and is intended to be used in conjunction with the project's installation drawings. The installation drawings should identify the applicable roof conditions, specify the components to be used and the required arrangements of the components. Specific building design and construction conditions may require variations from the information in this guide.

Delta Panels does not guarantee and is not liable for the quality of the installation. Delta Panels is not responsible for anything that may be attributable to improper installation, the negligence of other parties or from materials supplied by a third party.

Project Manager as used throughout this manual refers to the project's owner and/or his representatives, such as the project's architect, design engineer and general contractor.

These parties are responsible for determining the following.

- Selection of a competent Installer who is qualified and experienced in the proper installation of insulated building panels and their related flashing requirements.
- That the Installer has reviewed and understands the project's installation drawings and this guide prior to installation.
- The Panels and related components are installed in accordance with the project's installation drawings and the applicable sections of this guide.
- The Panels are suitable for the purposes intended.
- The Project's structural framing is properly designed and in satisfactory condition to accept the installation and design loads imposed by the panels.
- That the Panels and associated components are installed in compliance with the applicable building codes, engineering certifications, service conditions and good engineering and construction practices.

2. DELTA PANELS PROFILES

This Handling & Installation Guide covers the following Delta Panels™ Insulated roofing products.

DeltaTrim™

Standard Thickness (mm)	50, 75, 100, 125, 150, 175, 200
Core Material Options	SL Grade Polystyrene - Fire Retardant Grade PIR - Polyisocyanurate - Factory Mutual Approved TPC - Thermosetting Phenolic Composite MW - Mineral Wool DC - Dual Core
Effective Sheet Coverage	1000mm

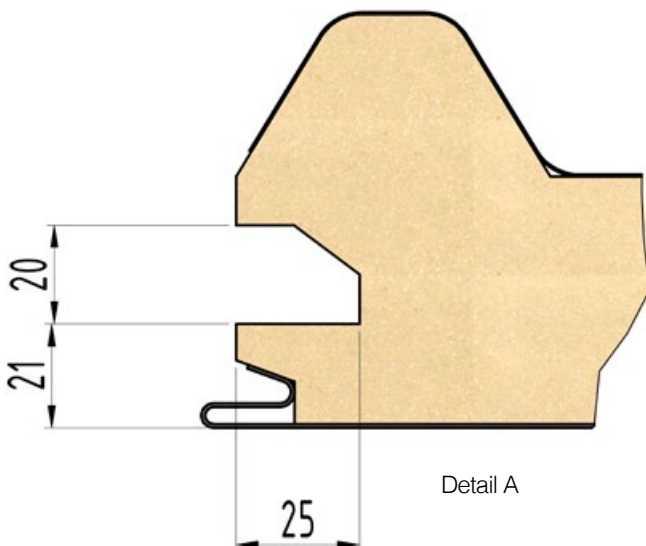
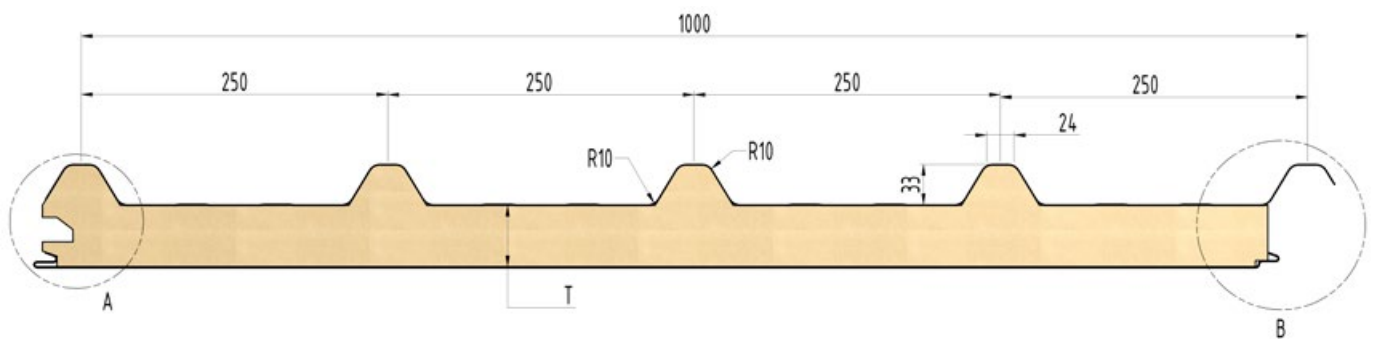
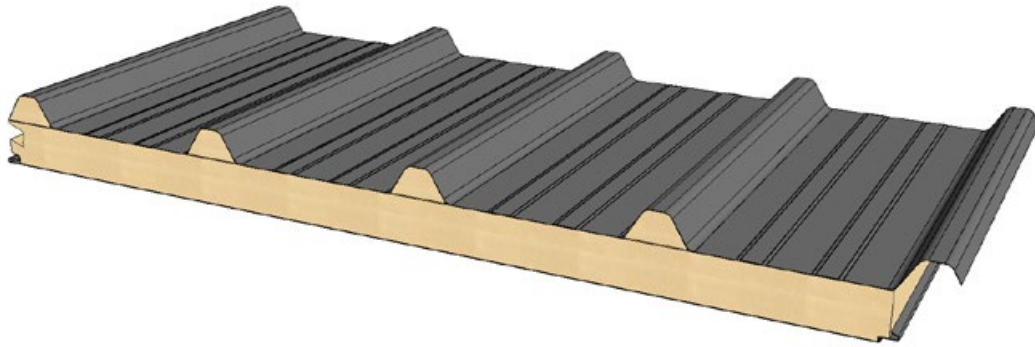

Detail A

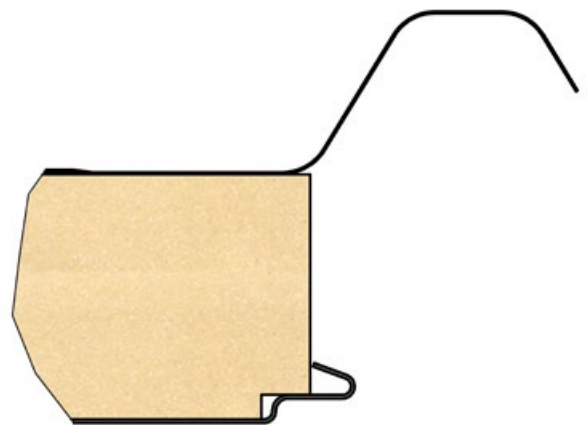

Detail B

2. DELTA PANELS PROFILES

This Handling & Installation Guide covers the following Delta Panels™ Insulated roofing products.

DeltaOrb™

Standard Thickness (mm)	50, 75, 100, 125, 150, 200
Core Material Options	SL Grade Polystyrene - Fire Retardant Grade PIR - Polyisocyanurate - Factory Mutual Approved TPC - Thermosetting Phenolic Composite MW - Mineral Wool DC - Dual Core
Effective Sheet Coverage	1000mm

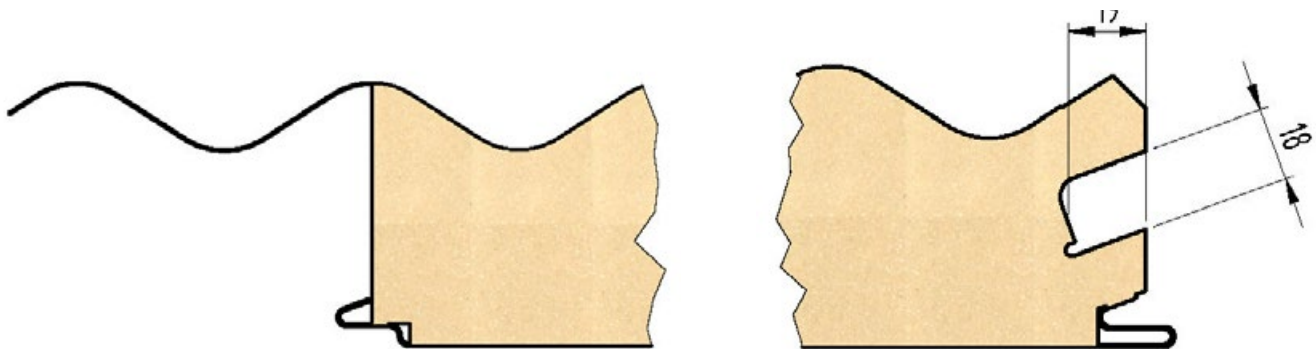
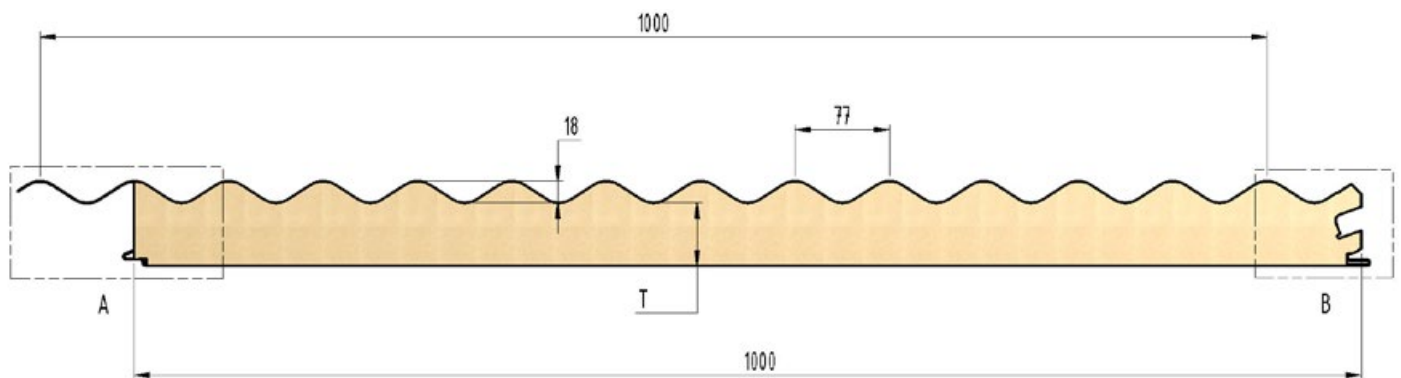
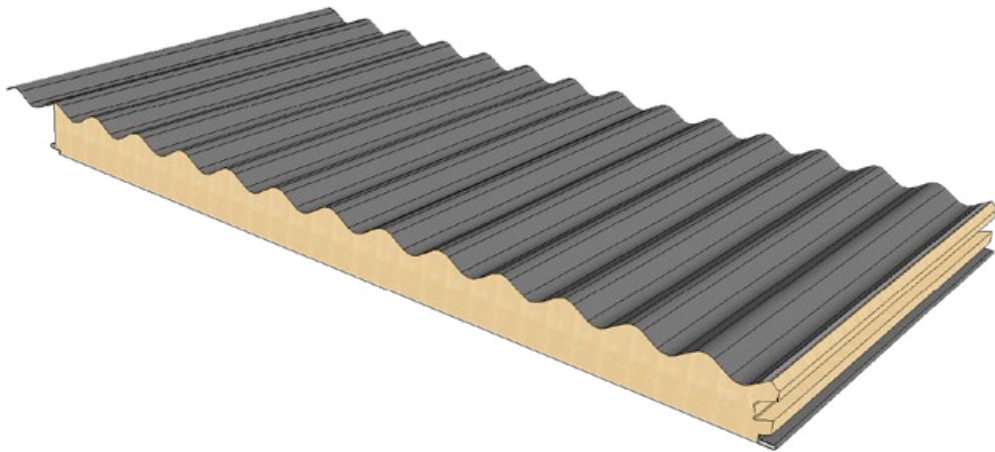

Detail A

Detail B

2. DELTA PANELS PROFILES

This Handling & Installation Guide covers the following Delta Panels™ Insulated roofing products.

DeltaCorroCorro™

Standard Thickness (mm)	75, 100, 125, 150, 175, 200, 225, 250
Core Material Options	SL Grade Polystyrene - Fire Retardant Grade PIR - Polyisocyanurate - Factory Mutual Approved TPC - Thermosetting Phenolic Composite MW - Mineral Wool DC - Dual Core
Effective Sheet Coverage	1000mm

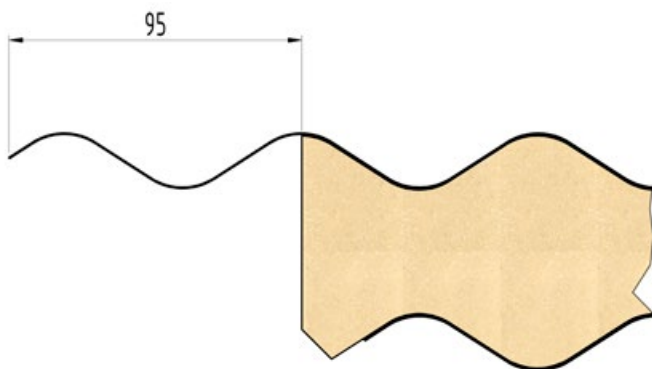
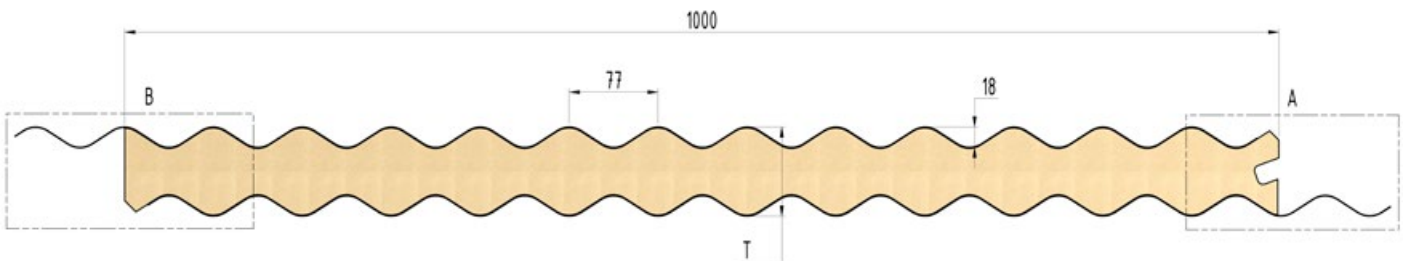
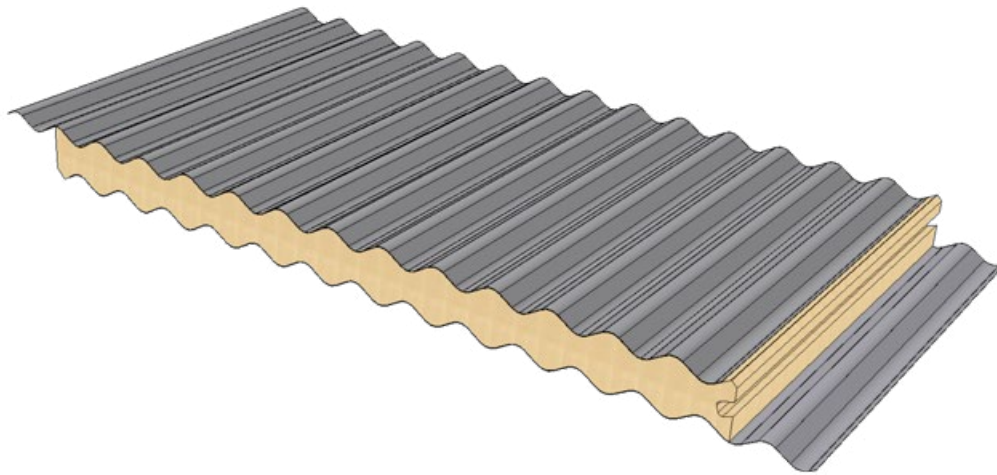

Detail B

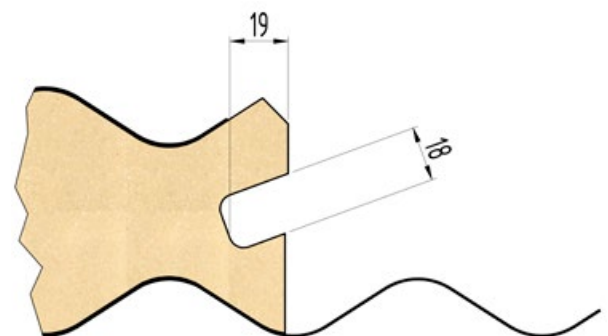

Detail A

2. DELTA PANELS PROFILES

This Handling & Installation Guide covers the following Delta Panels™ Insulated roofing products.

DeltaTrimTrim™

Standard Thickness (mm)	75, 100, 125, 150, 175, 200
Core Material Options	SL Grade Polystyrene - Fire Retardant Grade PIR - Polyisocyanurate TPC - Thermosetting Phenolic Composite
Effective Sheet Coverage	1000mm

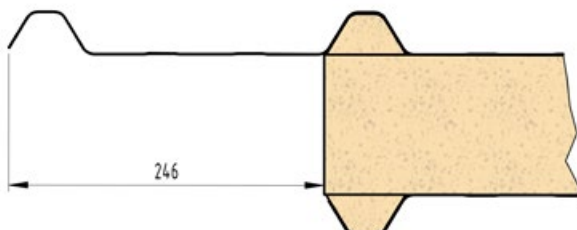
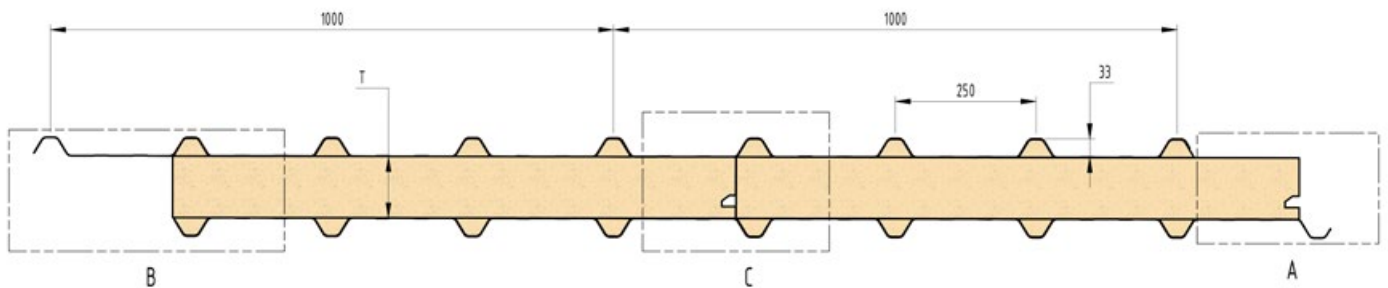
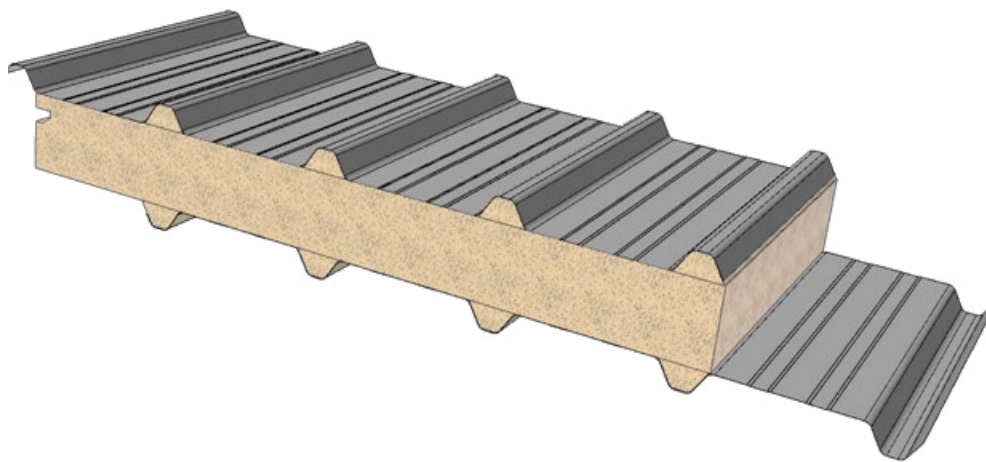

Detail B

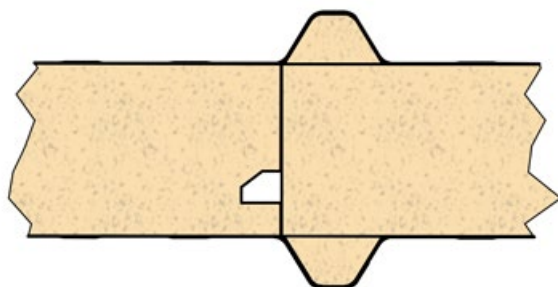

Detail C

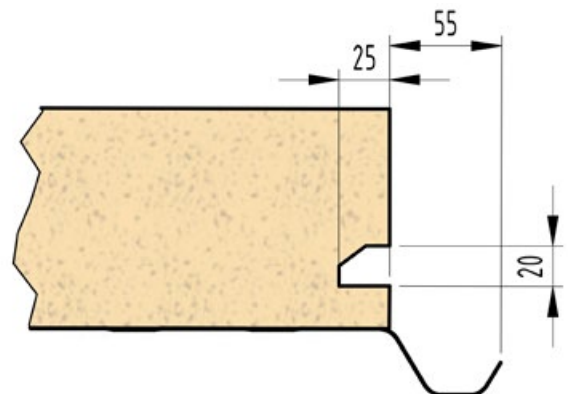

Detail A

2. DELTA PANELS PROFILES

This Handling & Installation Guide covers the following Delta Panels™ Insulated roofing products.

DeltaTrimCorro™

Standard Thickness (mm)	75, 100, 125, 150, 175, 200
Core Material Options	SL Grade Polystyrene - Fire Retardant Grade PIR - Polyisocyanurate TPC - Thermosetting Phenolic Composite
Effective Sheet Coverage	1000mm

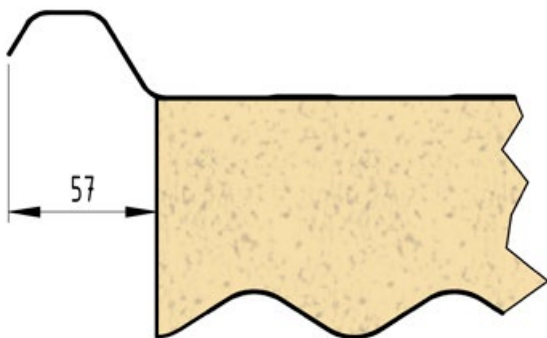
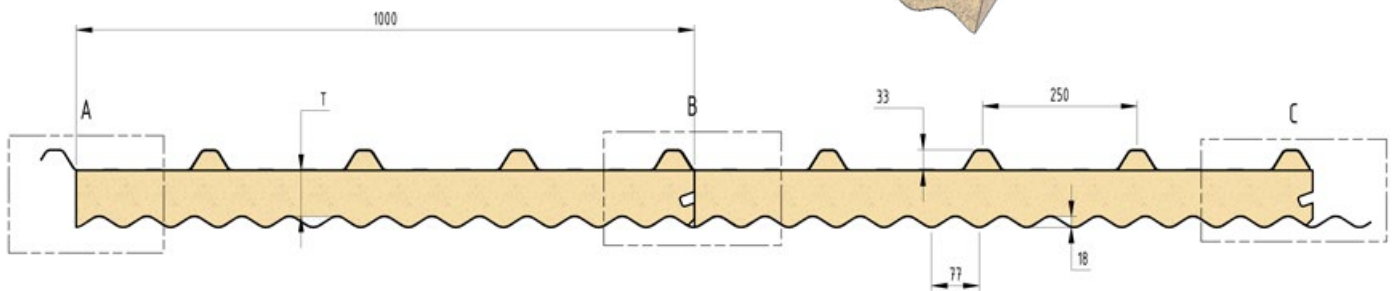
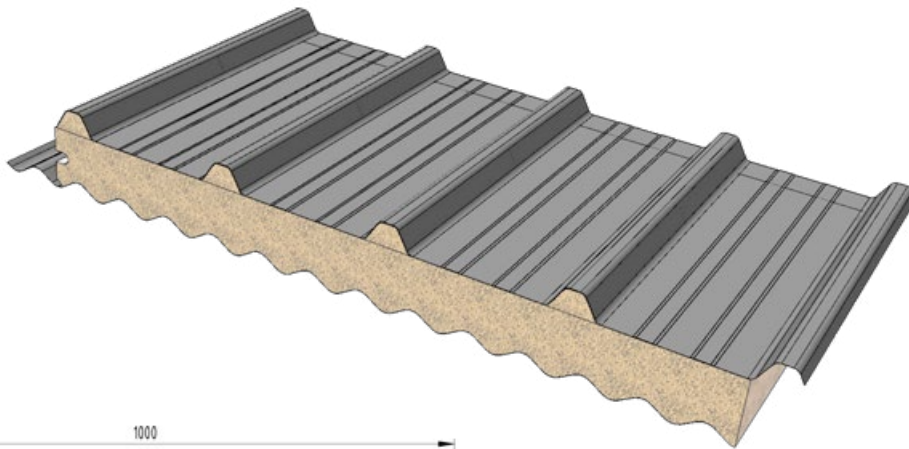

Detail A

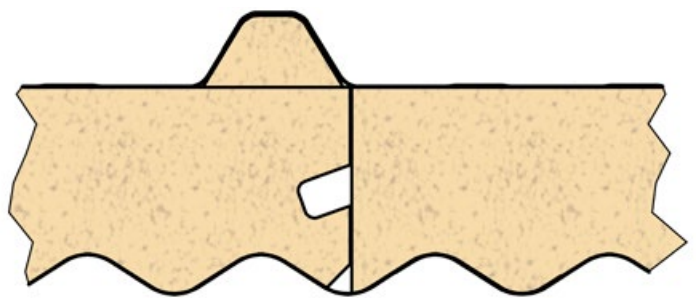

Detail B

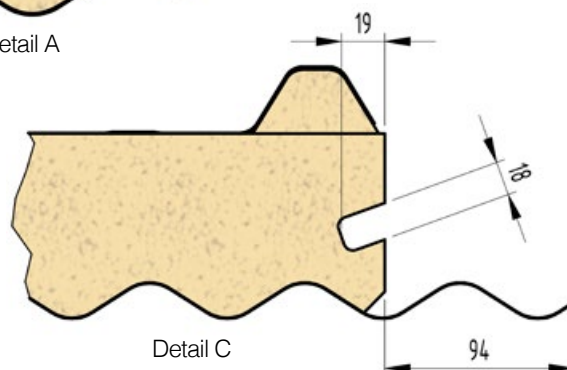

Detail C

3. SAFETY

Safety

The installation of roofing panels on any building structure requires careful planning to ensure all work can be carried out in a safe manner.

The establishment of a detailed Safe Work Method (SWM) as well as all onsite safety procedures are the responsibility of the Project Manager. The detailed Safe Work Method (SWM) must include the roles and responsibilities of all persons involved in the project. It must clearly outline what safety equipment is required, how it is to be utilized for each stage of the project and must comply with all aspects of the current Workplace Health and Safety Act. If the installer determines that they cannot install the panels in accordance with the installation drawings contained in this guide in conjunction with the Safe Work Method (SWM) requirements, it is their responsibility to determine appropriate alternative procedures, in conjunction with the Project Manager

Safety Data Sheets (MSDS)

Prior to the commencement of any installation, the panel installation contractor must read and familiarize themselves with the Safety Data Sheets (MSDS) applicable to the panel type being used. Current versions of Delta Panels Safety Data Sheets for Expanded Polystyrene - Fire Retardant Grade (EPS-FR), Polyisocyanurate (PIR), Thermosetting Phenolic Composite (TPC) and Mineral Wool (MW) panels are available upon request or online at www.deltapanel.com

General Safety Reminder.

- Hooks, wire cables and hardware used as tie-offs should be covered so that they do not scratch panel and trim surfaces.
- Use an approved and safe walking platform in high traffic areas to prevent damage to roof panels.
- Do not use panels as working platforms. Unsecured panels can slide or collapse under the weight of workers and equipment. Do not stand on the end of unsupported cantilevered panels, as this may result in panel collapse.
- Avoid point loads (concentrated loads in small areas). Heavy equipment, ladders and platform feet may cause panel damage that could result in collapse.
- Rain, dew, ice or sand can create unsafe footing on roof panels. Exercise caution and use nonslip footwear and/or working platforms.
- Do not install panels in high winds or other unsafe working conditions.
- Secure all loose panels with banding or tie-downs to prevent blowing off the roof. Use roof clamps as necessary to hold panels in place until fastening is complete.
- Use extreme caution on high pitched roofs - use adequate safety measures to prevent materials, equipment and workers from sliding off.
- Avoid panel and lifting equipment contact with electrical power lines, equipment and services.
- Verify that the roof structure is complete and properly aligned, with all connections and bracing in place and secured.

4. TOOLS & EQUIPMENT

List of Recommended Tools and Equipment

- All suitable Personal Protective Equipment(PPE) , including suitable protective gloves, footwear, headwear and eye protection
- Installation of temporary Safety Mesh (if deemed necessary under the SWM)
- Fall Restraints as defined by AS/NZS 1891.4:2009 (if deemed necessary under the SWM)
- Sufficient Sun Protection (hat, sunscreen etc)*
- Electric Leads with earth leakage device.
- Turn-Up / Turn-Down Tool or Wide Mouth Vice-grip Pliers
- Drill or Screw Gun, Drill Bits, Tek-Head Bits
- Electric Saw with appropriate metal blade or Nibblers
- Tin Snips
- Pop Rivet Tool
- Tape Measure
- Sharp thin-bladed Knife or Box Cutter
- Adjustable Carpenter's Square
- String / Chalk Line
- Marking Pen
- Spirit Level
- Old Blankets or equivalent
- Stable, fit-for-purpose Working Platform
- Plastic Paint Scraper
- Safety Harness
- Hard Hats
- Appropriate Footwear
- Scissor Lifts, Scaffold and/or Ladders

** sunscreen can cause paint deterioration if it comes into contact with the surface of the panel*

5. DELIVERY RECEIVALS & STORAGE

Receiving Panel Packs

- The panels are carefully packed to protect them during transport.
- They are a ready-to-install, finished product and special care should be taken when unloading and handling them to avoid permanent damage to the panels. Particularly the underside ceiling.
- Ensure that adequate lifting equipment (ie crane or forklift) is available prior to the delivery truck arriving
- Ensure that a suitable level location is available to store the off-loaded panels in.
- When unloading the truck, the packs of panels will have attached stickers indicating the correct lifting points.



- For packs of panels under 8 meters a forklift may be used.
- For longer packs a forklift with spreader lifting lugs is recommended.



5. DELIVERY RECEIVALS & STORAGE



- For longer packs the panel packs will need to be craned off the delivery vehicle
- If the panels exceed 8 meters a spreader bar is required to ensure that the slings do not cause any damage to the packs.
- The packs of panels should be stored correctly on the site in an area that will eliminate any chance of damage occurring to the packs
- The Delivery Docket will clearly state the quantity, description and type of panels delivered along with any associated components. It is the owners responsibility to cross check the delivery docket with the actual goods received at the time the goods are received.

Onsite Storage

- The panels should not be unpacked until it is time to install them, in the meantime they should be stored in an area away from traffic to eliminate the possibility of damage.
- Panels exposed to direct sunlight can result in Thermal Bowing which can prevent proper engagement during installation. Store the panels in a shaded area or leave the panels fully packaged until required for installation.
- All protective packaging when removed should be disposed of correctly
- Be aware that there is protective film on the steel surfaces, of the panels if this film is left exposed to sunlight for a period of time it may become difficult to remove. It is advised to keep the original packaging shroud over the top of the panel packs to eliminate sun exposure
- Keep panels a safe distance from other on site trades that are welding, cutting or painting.
- No other materials are to be stored or stacked on top of the panel pack.

6. HANDLING OF THE PANELS

Insulated roofing panels are used in a wide variety of different construction, applications, varying from household patios and awnings through to major commercial and industrial roofing projects. Depending upon the actual application and the working condition of the construction site, panels can be moved into their installation position by various means.

For larger commercial and industrial projects panel installation time is typically reduced when using lifting equipment. However the equipment must be designed to cater for the panel lengths, weights and profiles to be lifted. It is therefore important to verify the requirements of your specific project with the company supplying the lifting equipment.

Manual Lifting

- The use of safety gloves along with wrist protection is advisable when handling metal panels
- When lifting the panels off the pack always lift the panels vertically.
- Do not slide them across each other or twist sideways.
- Always lift from the underside, never lift using the top sheet.

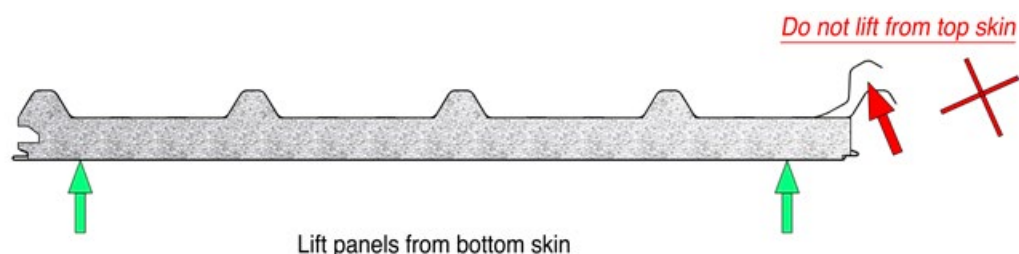

- Care must be taken to avoid damage to the corners and overlaps.
- When relocating long panels always carry them on their edge, with one worker at either end, plus an additional worker at 3.5 metre intervals.
- When placing panels down, always place them down vertically & onto a non-abrasive, flat & stable support.
- Never drag panels, always lift and carry them to protect the panel surfaces from scratching.

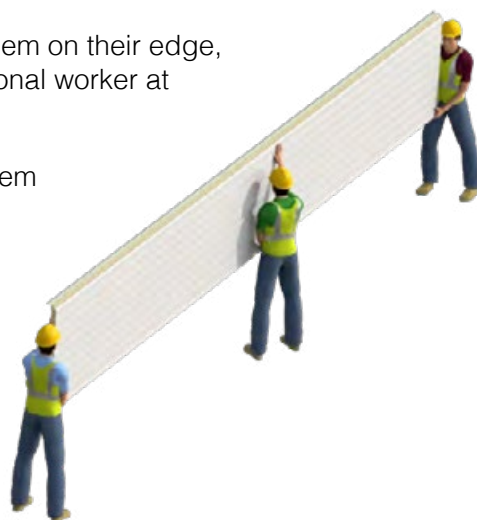

6. HANDLING OF THE PANELS

Crane and Sling

- A crane can be used to lift either an entire pack of panels onto the roof or place individual panels into their final fixing position
- When lifting an entire pack of panels it is important to verify that the building structure will support the weight of the pack, prior to placing on the roof. Verify the exact location(s) where any bundles are allowed to be placed.
- Care must be taken to correctly align the sling to the marked lifting points
- Panel bundles placed on roof must be secured to roof framing members. Panels in opened bundles must be secured to prevent sliding off the roof.
- Set the packs onto the roof in the proper orientation for the erection sequence
- A spreader bar must be used to ensure that the load is evenly disturbed.
- A spreader bar must be used to ensure that the lifting straps do not squeeze in on the panels causing any deformation to the panel's edges and delamination of the skins
- Protective blocks are to be used under the slings to ensure that the steel skins are not deformed or crushed during the lifting process.

Packs under 1800 kgs and less than 10 meters

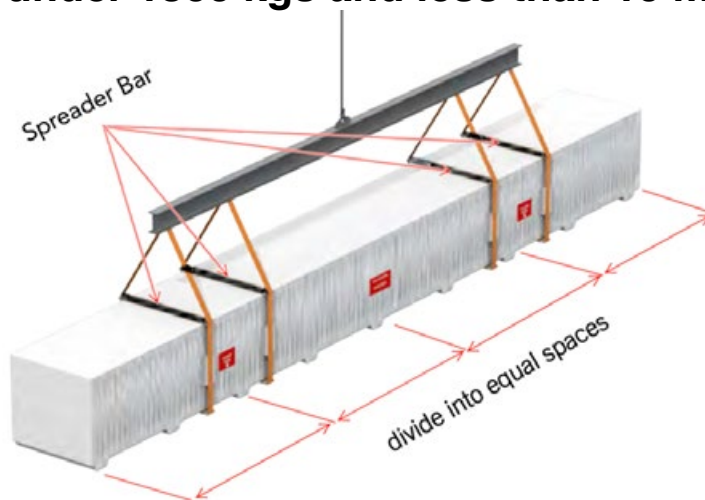

Packs over 1800 kgs and/or over 10 metres

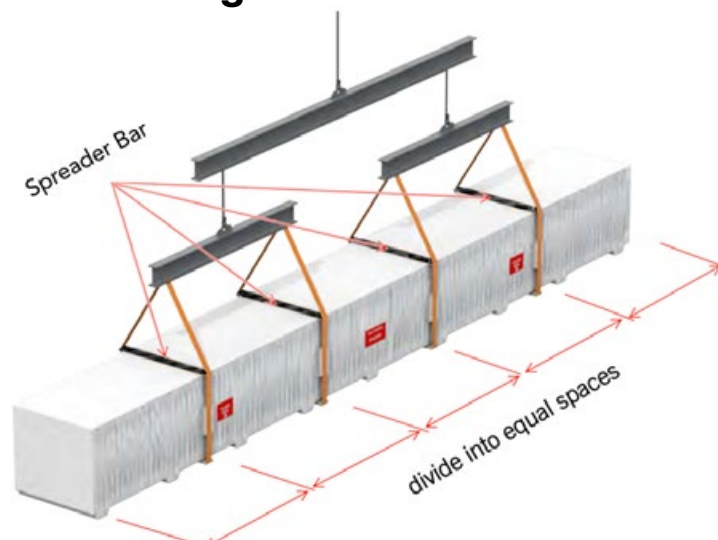

6. HANDLING OF THE PANELS

Vacuum Lifting

Individual panels can be lifted up onto the roof using a vacuum lifter (clad-boy) with outriggers. An alternative method is the use of slings.

The vacuum lifting equipment must be designed to cater for the panels lengths, weights and the profile of the top sheet.



7. FRAMING ALIGNMENT

It is important that any dimensional differences between the actual building framework and the drawings is resolved prior to the installation of the panels. Improper framing alignment can cause difficulty with panel engagement resulting in rippling or buckling of the panel faces.

- Framing alignment should be checked before panels are installed.
- Compare structural and panel installation drawings to ensure roof supports are in correct location.
- Carry out an on-site measurement of the support spacing and overall building dimensions.
- All supports not in alignment must be corrected by the responsible party before panel installation begins.

8. INSTALLATION - PANEL PREPARATION

It is essential that the ends of the panels are properly treated for weather proof protection. That is, they are either turned up (at the receiver channel or ridge cap end) and turned down (at the gutter fascia end).

8.1 - Prepare Ends

Run a sharp knife or box cutter between the roof panel and the insulation core to cut the glue bond. You will need to go to a depth of at least 30mm.



8.2 - Turn up End

Turn up all roof pans at the top end of the panel to full rib height using your Turn-up/Turn-down Tool or Wide Mouth Vice-grips as illustrated.



8.3 - Trim Overlap

Trim both the overlay rib at the top end and the underlay rib at the gutter end using tin snips. This is to allow the panel to lap properly once turned up at the top end and to stop capillary action drawing water back along the underlay leg at the gutter end.



8. INSTALLATION - PANEL PREPARATION

8.4 - Remove Underneath Protective Film

Turn the panel over on the trestles and remove any left over insulation core from the gutter cutback end of the panel to a depth of at least 30mm.



8.5 - Remove Plastic Film

Peel back the clear plastic protective coating from the underside/ceiling face of the panel approximately 100mm at top end to fit into the receiver channel. Peel back sufficient clear plastic protective coating to clear supporting beam at the gutter end. Clear plastic protective coating should be completely removed from each panel after each panel is fitted.



8.6 - Turn Down

Turn the panel back over and turn down all roof pans at the gutter end approximately 20° using Turn-Up/Turn-Down Tool or Vice-grips.



9. INSTALLATION - PANEL CUTTING

Equipment Recommendations

- Personnel cutting panels should always wear safety glasses, gloves and long sleeve shirts.
- Panel cutting should take place prior to installation when possible.
- Use care when using saws to avoid panel delamination; make sure the blade is sharp and let the saw cut at its own pace - do not force.
- Use the following cutting tools to avoid panel damage:
 - Circular Saw with metal cutting blade or panel thumper blade
 - Nibblers
 - Panel saw



- The use of abrasive saws/grinder blades will damage the paint finish and metal facings
- For small penetrations, cut each panel face with a portable router, then cut the foam with a serrated knife. Metal flashings may be cut with power snips, nibblers or hand snips.



Cutting Recommendations

- Place the panel on padded sawhorses.
- Clean any surface grim and debris off panel face to be cut with clean rag.
- Mark cut line with chalk or washable felt tip marker.
- Masking tape may be applied on both sides of cut line to minimize panel scratching.
- Recheck measurements and cut with appropriate tool.
- Remove burrs at cut edges with deburring tool.



10. INSTALLATION - CLEANING

- Metal shavings from cutting and drilling should be removed as panels are erected using a soft bristle brush or clean cotton rag.
- For general cleaning, use a low pressure power wash with plain water. If necessary, use carwash soap or a 5% solution of mild laundry detergent. Use a clean cotton rag, sponge or soft bristle brush as required. Rinse thoroughly.
- Sealants, grease, tar and wax can be removed from panels and trim by using WD-40. Apply to a clean cotton rag, and avoid smearing over a large area. Then follow up with general cleaning instructions as above.
- For rust stains, remove the source (typically metal filings), then clean the affected area using one of the following methods: soap and water, or citrus oil based cleaning fluids.
- Concrete/mortar splatter must be washed off immediately with a high pressure wash and mild detergent.
- Do not use solvents, wire brushes, steel wool, or any other abrasive method to clean the painted surface of panels

11. INSTALLATION - TOUCH UP

- Touch-up paint is for minor scratches only.
- Colour coded touch-up pens can also be used for small scratches.



- Test all touch up colours on an off-cut piece of panel to ensure that the paint colour is a correct match prior to applying to the finished roof section
- Clean affected area with a clean cloth, and apply touch up to the scratch.
- Allow 30-45 minutes for tack free and 24 hours for complete drying.

12. INSTALLATION - FASTENERS, FLASHINGS, FOAM INFILLS STRIPS AND SEALANTS

Screw Types

Main Fasteners with Cyclone Plate and Washer

Metal Tek - Fixing

Fixing into Steel Beams up to 12.5mm

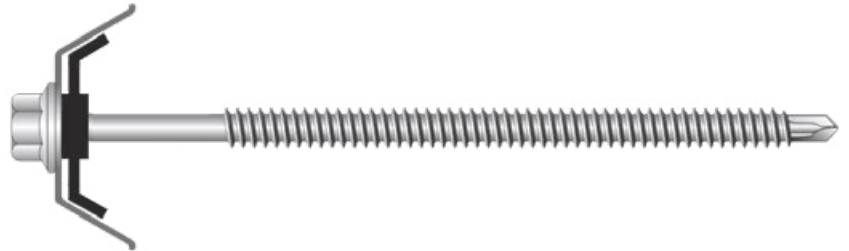

T17 - Fixing

Fixing into Timber Beams

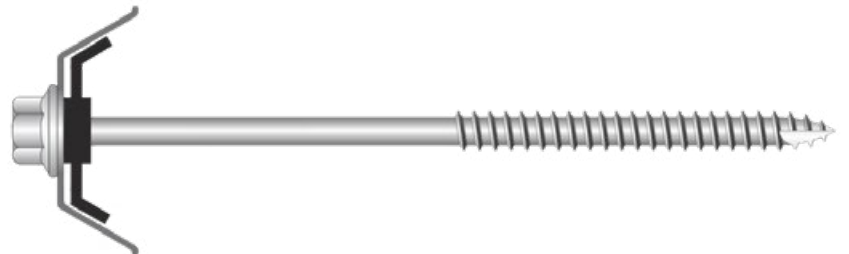

Secondary Fasteners

Tek M13 x 25mm



Tek M10 x 16mm



Dome Rivet 73 AS 4.3



Spacings for Secondary Fixings:

Top-Skin Overlap - DeltaTrim™, DeltaOrb™, DeltaCorroCorro™, DeltaTrimTrim™ & DeltaTrimCorro™	
Stitching Spacings	No. of fixings required
300mm centres	1 x M13 x 25mm Tek Screw with Neo Washer
Flashings & Rainwater Goods	
Fixing Spacings	No. of fixings required
300mm centres	For G300 1.2mm Structural Flashings : - 1 x M13 x 25mm Tek Screw with Neo Washer
400mm centres	For G300 0.55mm Flashings : - 1 x Dome Rivet 73 AS 4.3, or 1 x M10 x 16mm Tek Screw with Neo Washer

12. INSTALLATION - FASTENERS, FLASHINGS, FOAM INFILLS STRIPS AND SEALANTS

Screw Selection Tables

DeltaTrim™					
Minimum Class 3 - must be HEX Head	Steel Beam	Timber Beam	Minimum Class 3 - must be HEX Head	Steel Beam	Timber Beam
50mm	135mm	125mm	150mm	230mm	230mm
75mm	150mm	150mm	175mm	260mm	265mm
100mm	175mm	175mm	200mm	260mm	300mm
125mm	200mm	200mm			

DeltaOrb™					
Minimum Class 3 - must be HEX Head	Steel Beam	Timber Beam	Minimum Class 3 - must be HEX Head	Steel Beam	Timber Beam
50mm	115mm	125mm	150mm	200mm	230mm
75mm	135mm	150mm	175mm	230mm	265mm
100mm	150mm	175mm	200mm	260mm	300mm
125mm	175mm	200mm			

DeltaCorroCorro™					
Minimum Class 3 - must be HEX Head	Steel Beam	Timber Beam	Minimum Class 3 - must be HEX Head	Steel Beam	Timber Beam
75mm	115mm	125mm	175mm	200mm	230mm
100mm	135mm	150mm	200mm	230mm	265mm
125mm	150mm	175mm	225mm	260mm	265mm
150mm	175mm	200mm	250mm	300mm	300mm

DeltaTrimTrim™					
Minimum Class 3 - must be HEX Head	Steel Beam	Timber Beam	Minimum Class 3 - must be HEX Head	Steel Beam	Timber Beam
75mm	200mm	200mm	150mm	260mm	265mm
100mm	230mm	230mm	175mm	300mm	300mm
125mm	230mm	230mm	200mm	300mm	300mm

DeltaTrimCorro™					
Minimum Class 3 - must be HEX Head	Steel Beam	Timber Beam	Minimum Class 3 - must be HEX Head	Steel Beam	Timber Beam
75mm	175mm	175mm	150mm	260mm	265mm
100mm	200mm	200mm	175mm	300mm	300mm
125mm	230mm	230mm	200mm	300mm	300mm

12. INSTALLATION - FASTENERS, FLASHINGS, FOAM INFILLS STRIPS AND SEALANTS

COMPONENTS:

Flashings

Flashings unless otherwise noted are to be made from 0.55mm steel and installed to AS 1562.1:2018. Aluminium can be used but referral to IPCA for cold storage compliance is advised.

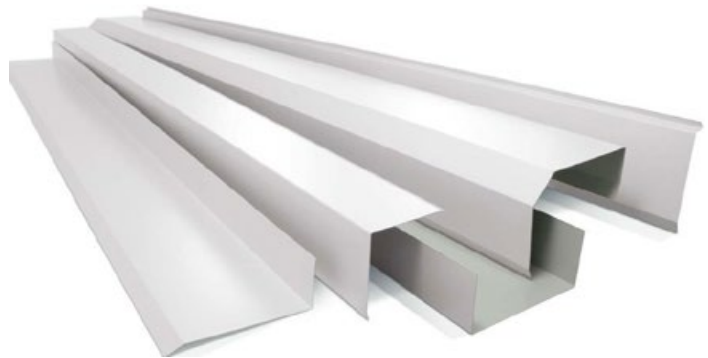

Foam Infill Strips



Butyl Rubber Adhesive Tape for Metal Roofing



Sealant for Metal Roofing

The sealant should be of neutral cure and meet the recommendations as outlined in BlueScope TB-9 Sealants for Exterior Finishes.



13. INSTALLATION - PANEL LAYOUT

Depending from which way the prevailing weather originates, the panels should be orientated so that the overlaps of the top skins face away from the direction of the prevailing weather.

When defining the panel layout the starting point is based on looking from the gutter end towards the ridge.

Delta Panels insulated roofing products are designed to be able to be installed from either right to left or alternatively left to right.

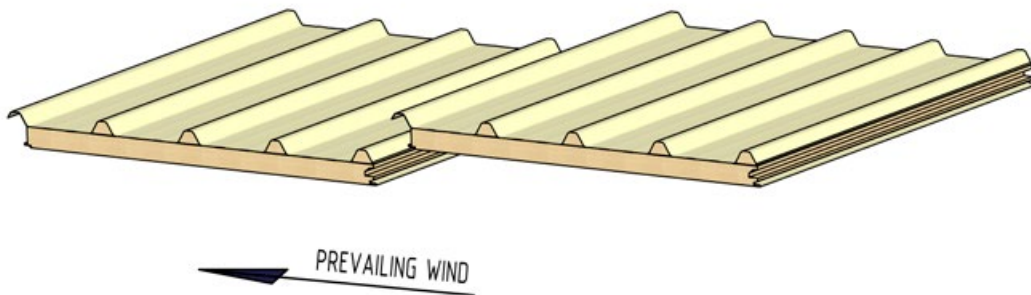

When ordering a roof panel the length designated is always that of the top skin NOT the length of the cut-backed bottom skin. A right hand cut-back would be defined as a panels starting on the right hand side of the roof with the subsequent panels being laid from right to left.

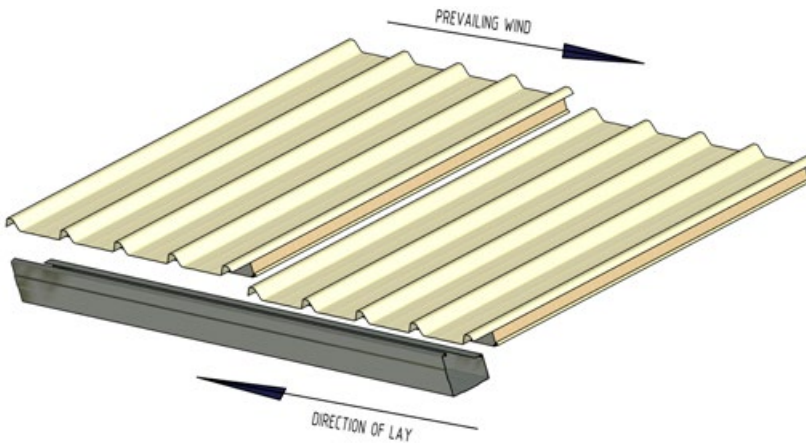

Right Hand Cut-Back

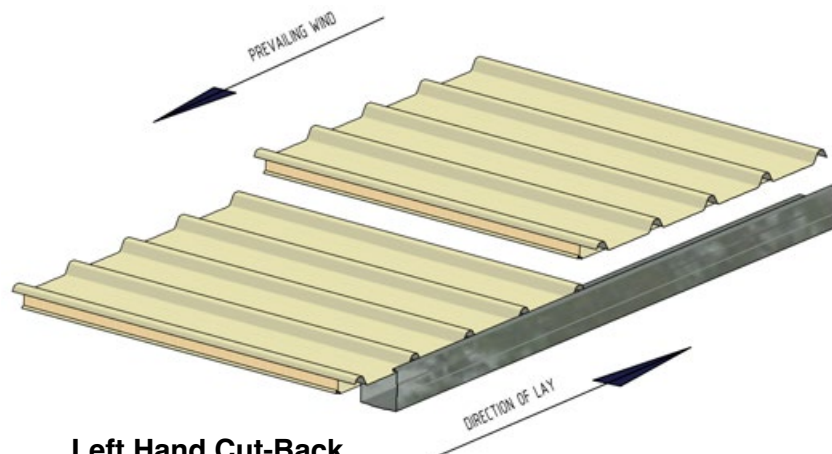

Left Hand Cut-Back

13. INSTALLATION - PANEL LAYOUT

13.1 - Installing the First Panel

- Fixing Details - Refer to Section 14 - Connection Details for the appropriate standard panel connection for the type of panel being used on the project.
- Fastening Information - Refer to Section 12, Screw Selection Table for the correct fastener.
- Factory Mutual - If the project is being constructed to conform to a Factory Mutual certification, please refer to the Factory Mutual web site for the Delta Panels approved fastener systems.

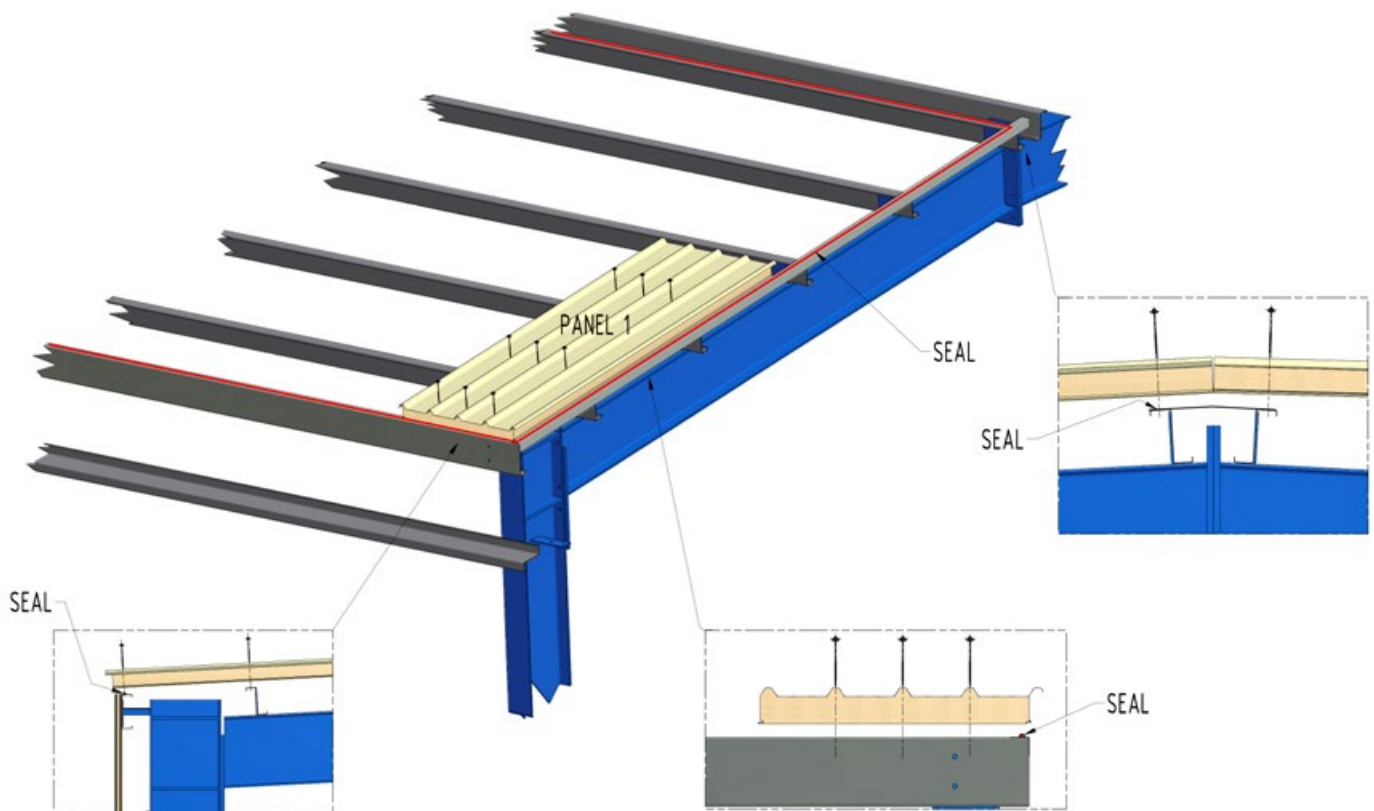

13. INSTALLATION - PANEL LAYOUT

13.2 - End Lap Joint Procedure

- Fixing Details - Refer to Section 14 - Connection Details which shows two options for the end-lap joints or the step joint.
- Fastening Information - Refer to Section 12, Screw Selection Table for the correct fastener and end lap stitching screw.
- Factory Mutual - If the project is being constructed to conform to a Factory Mutual certification, please refer to the Factory Mutual web site for the Delta Panels approved fastener systems

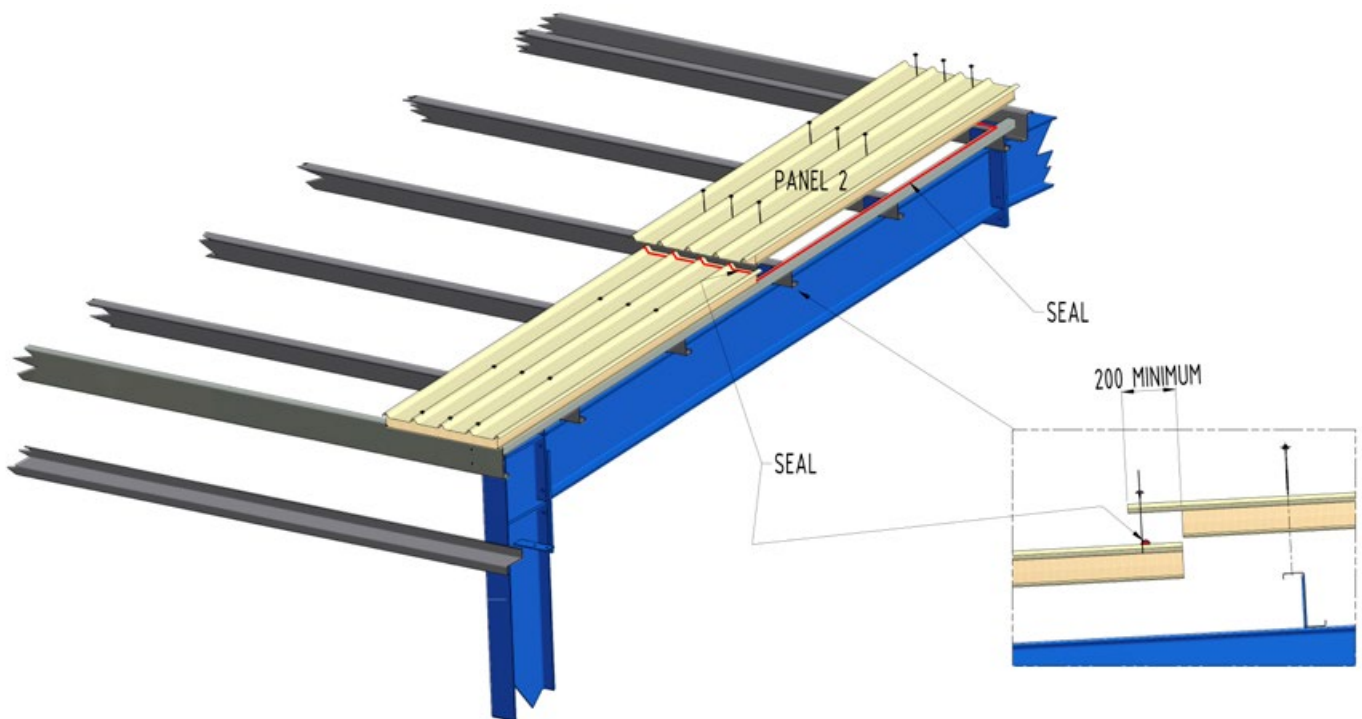

13. INSTALLATION - PANEL LAYOUT

13.3 - Direction of Installation, with Purlin fixings

- Fixing Details - Refer to Section 14 - Connection Details which shows the correct process for thermal stress cut & fixings.
- Panel to Panel joining - Refer to Section 14 - Connection Details for the appropriate panel to panel connection for the type of panel being used on this project.
- Fastening Information - Refer to Section 12, Screw Selection Table for the correct fastener and stitching screw for both end laps and panel to panel overlap.
- Factory Mutual - If the project is being constructed to conform to a Factory Mutual certification, please refer to the Factory Mutual web site for the Delta Panels approved fastener systems.

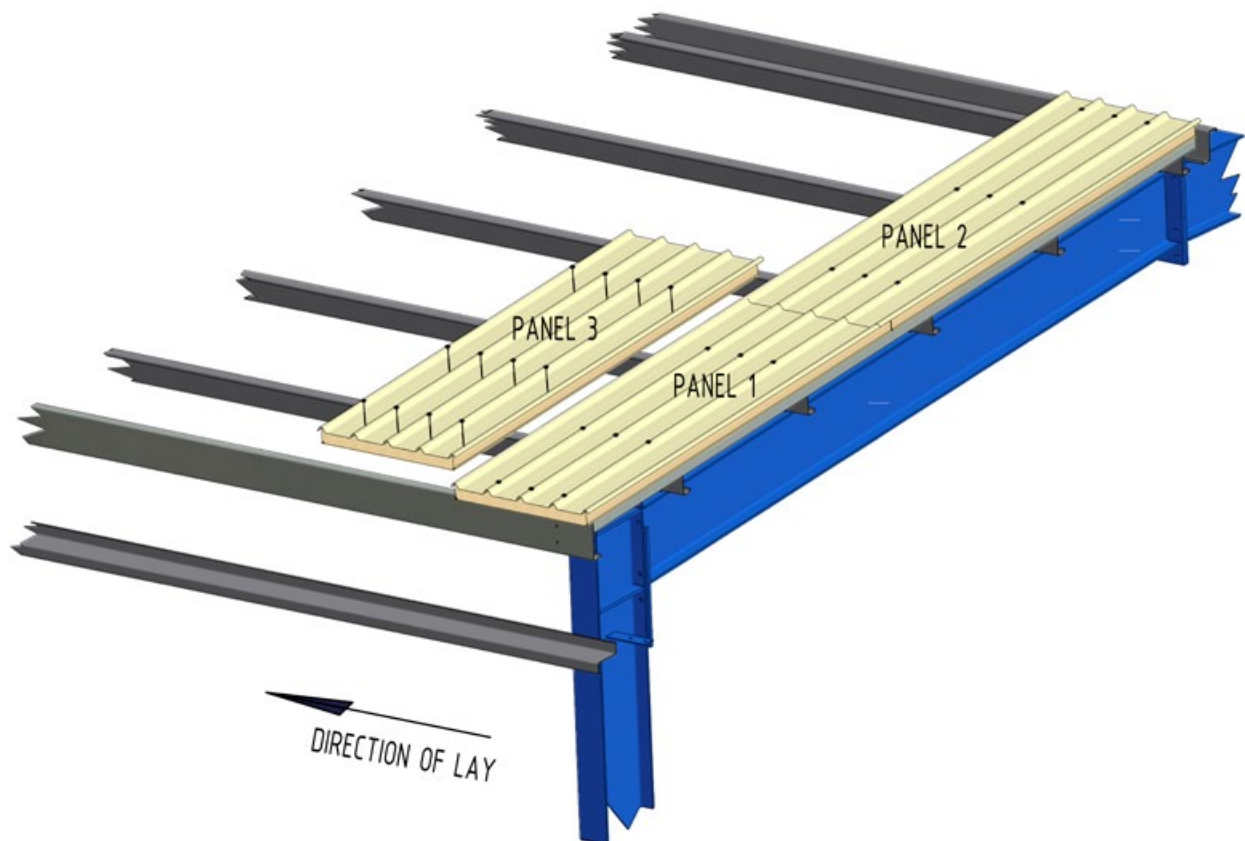

13. INSTALLATION - PANEL LAYOUT

13.4 - Stitch Screwing

- Fastening Information - Refer to Section 12, Screw Selection Table for the correct fastener and stitching screw for both end laps and panel to panel overlap.
- Panel to Panel joining - Refer to Section 14 - Connection Details for the appropriate panel to panel end overlap connection for the type of panel being used on this project.
- Factory Mutual - If the project is being constructed to conform to a Factory Mutual certification, please refer to the Factory Mutual web site for the Delta Panels approved fastener systems.

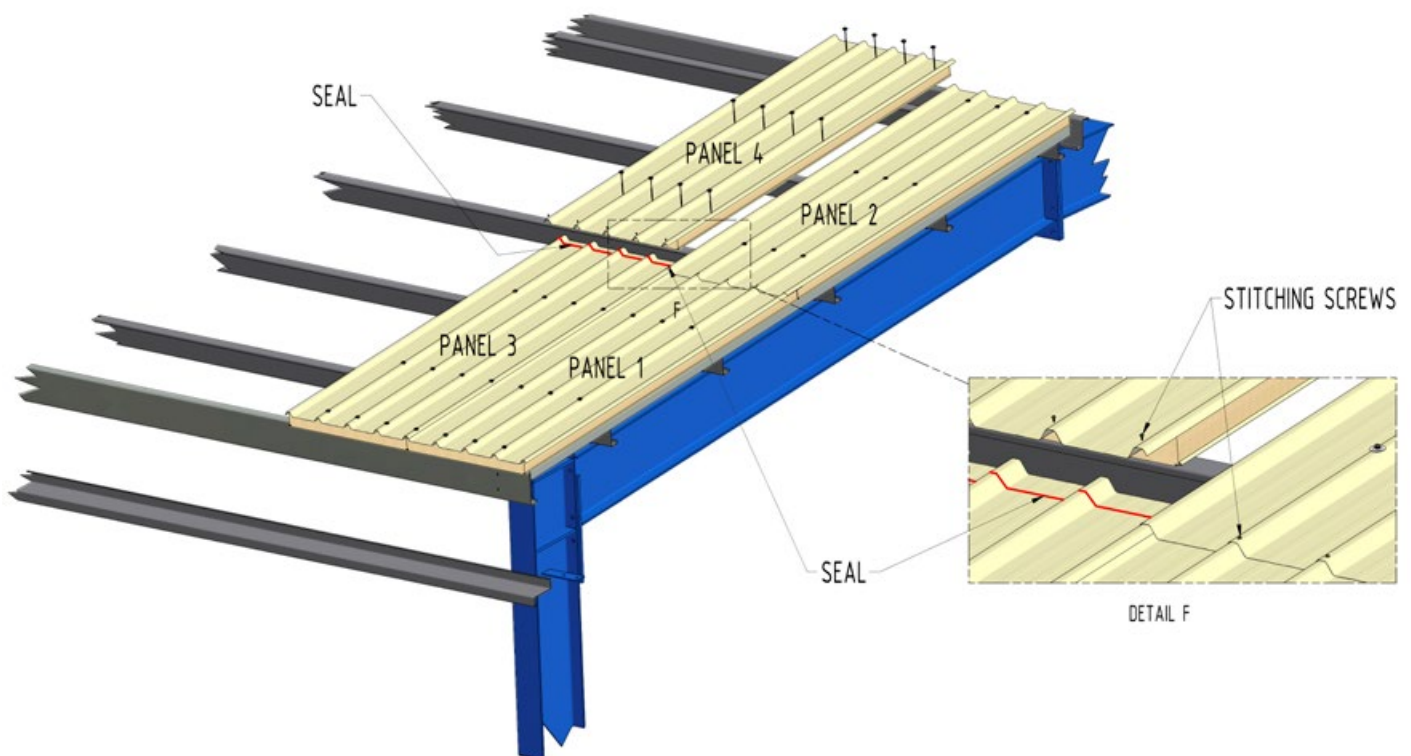

13. INSTALLATION - PANEL LAYOUT

13.5 - Ridge Capping & Gutter Installation

- Ridge Capping - Refer to Section 14 - Connection Details for the appropriate gutter capping details and internal flashing.
- Gutter Installation - Refer to Section 14 - Connection Details for the appropriate gutter detail.
- Fastening Information - Refer to Section 12, Screw Selection Table for the correct fastener and stitching screw for both the ridge capping and gutter installation.
- Factory Mutual - If the project is being constructed to conform to a Factory Mutual certification, please refer to the Factory Mutual web site for the Delta Panels approved fastener systems.

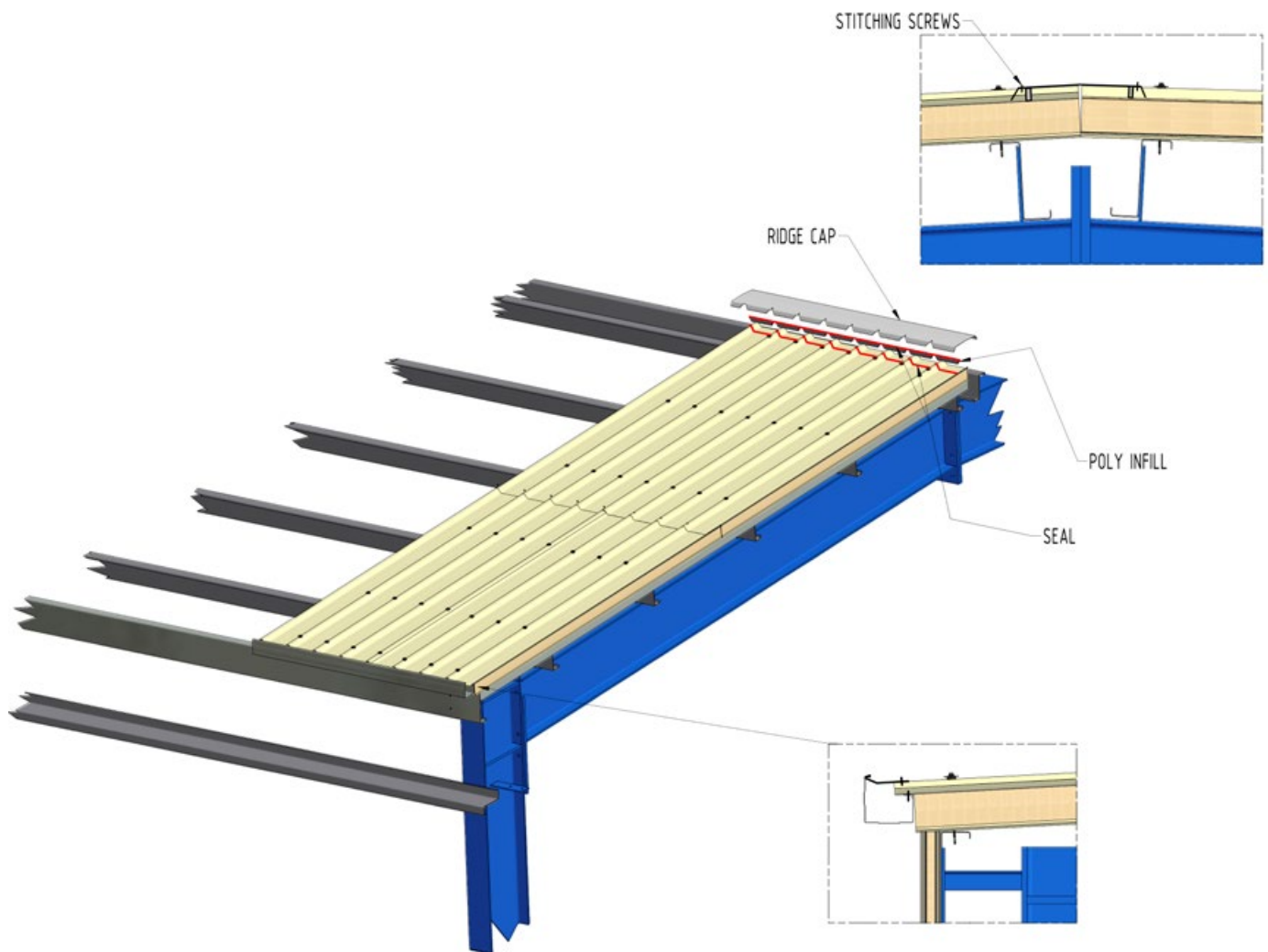

13. INSTALLATION - PANEL LAYOUT

13.6 - Side Barge Installation

- Side Barge Capping - Refer to Section 15 - Installation Flashings for the side barge appropriate to the panel used on the project.
- Fastening Information - Refer to Section 12, Screw Selection Table for the correct fastener and stitching screw for both the ridge capping and Gutter installation.
- Factory Mutual -If the project is being constructed to conform to a Factory Mutual certification, please refer to the Factory Mutual web site for the Delta Panels approved fastener systems.

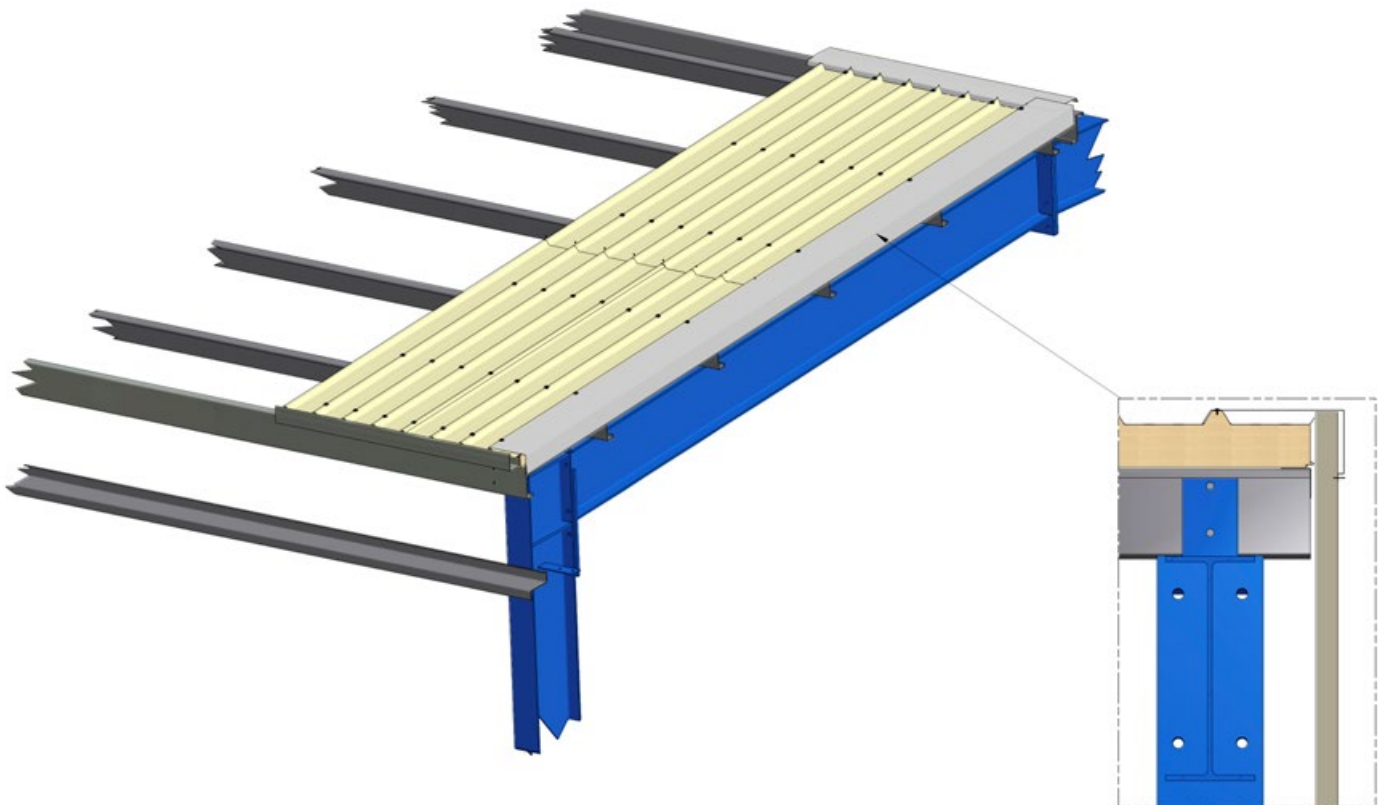

14. INSTALLATION - CONNECTION DETAILS

Roof Panel to Concrete Parapet Wall

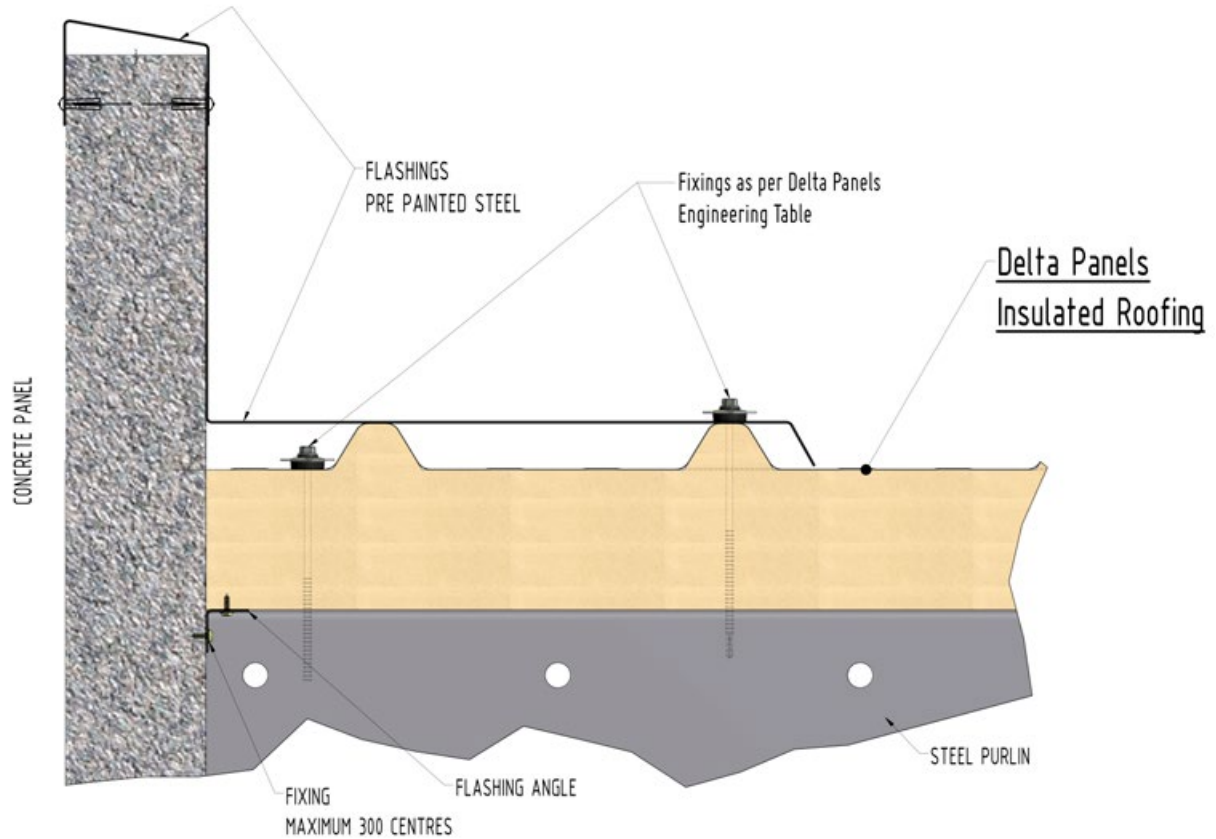

Roof Panel to Panel Wall - Gutter Detail

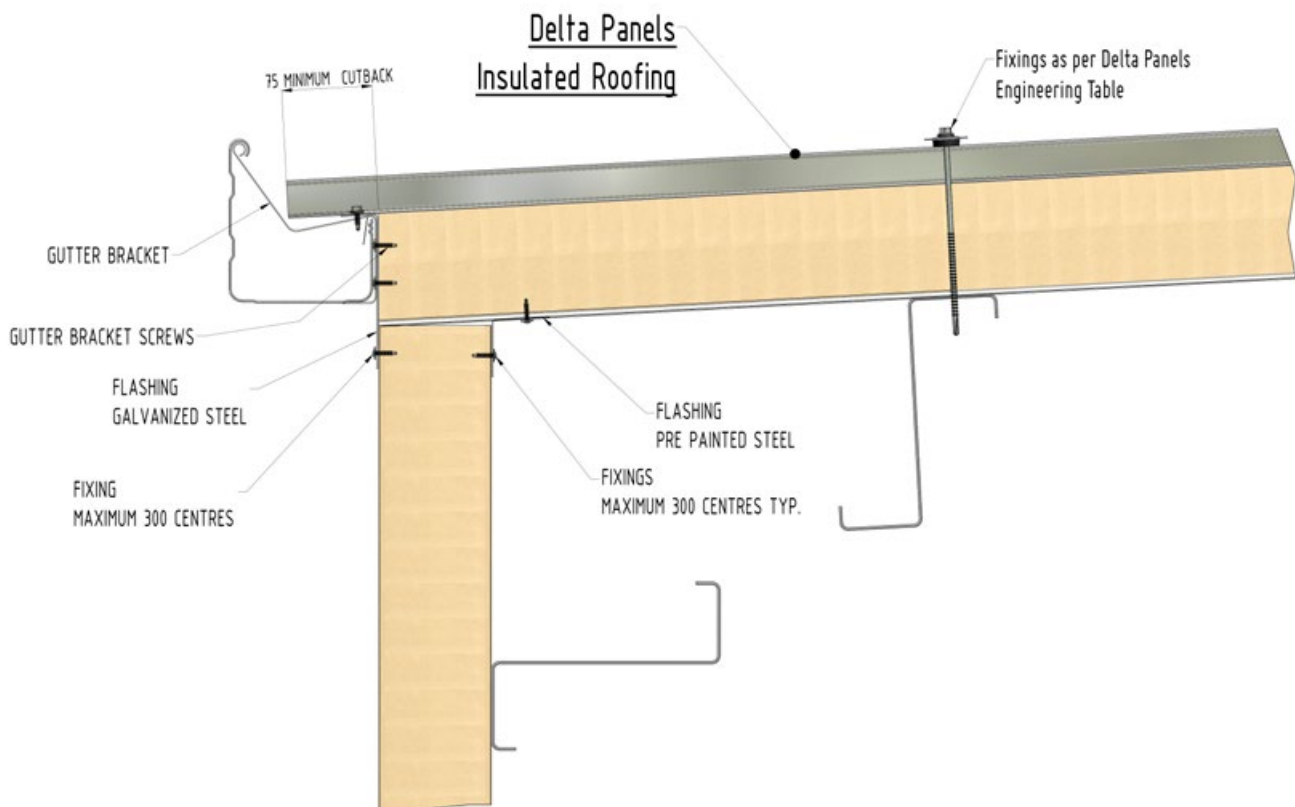

14. INSTALLATION - CONNECTION DETAILS

Roof Panel to Panel Wall - Corner Flashing Detail A

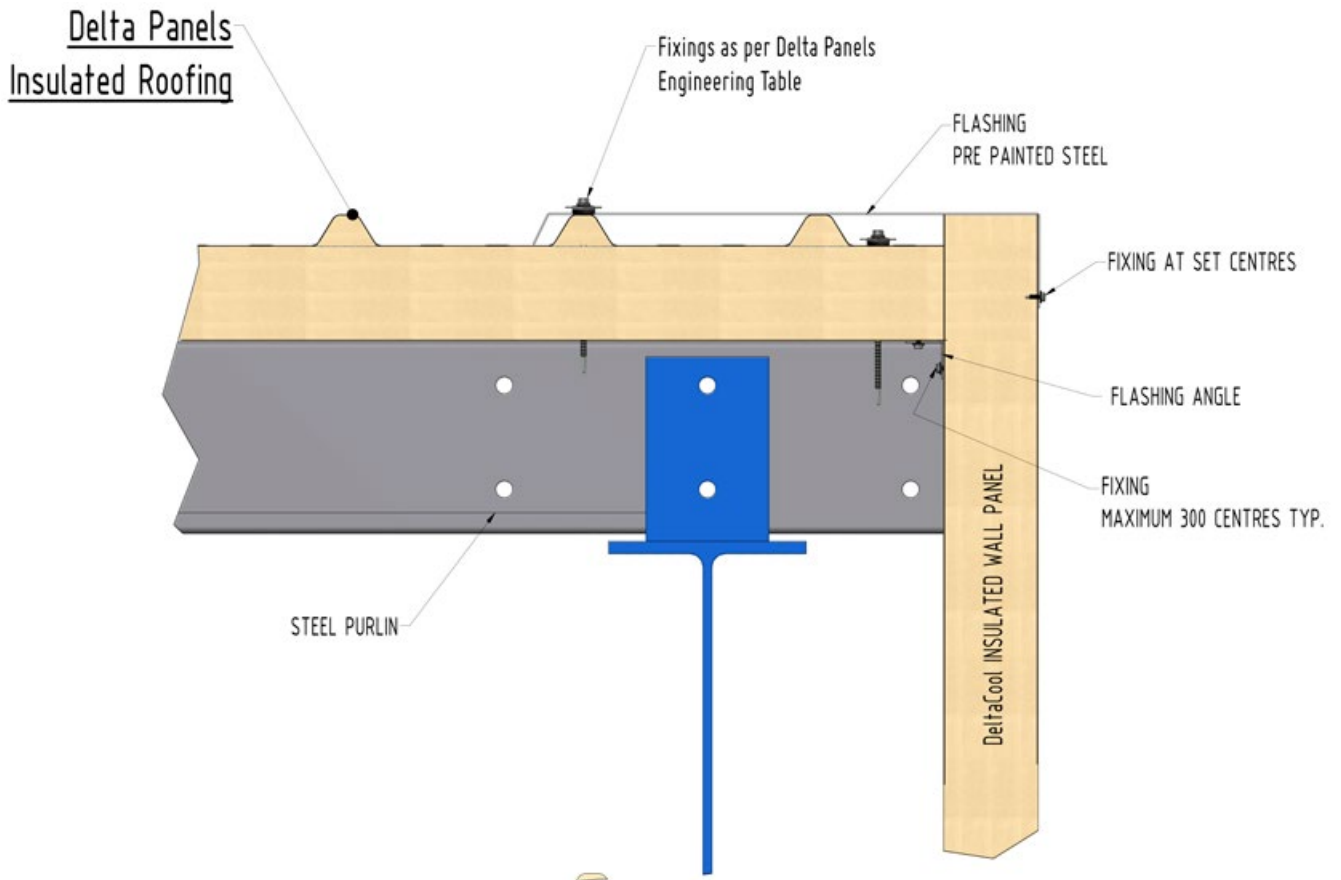

Roof Panel to Panel Wall - Corner Flashing Detail B

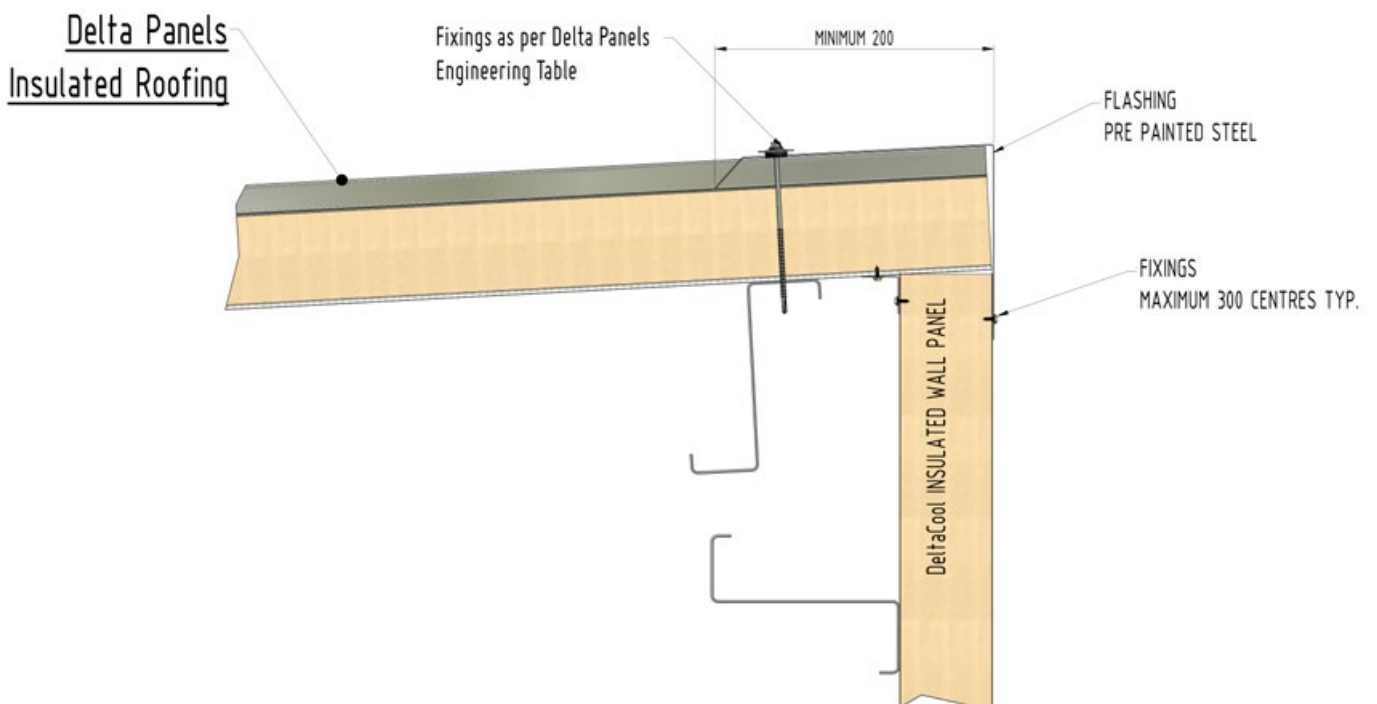

14. INSTALLATION - CONNECTION DETAILS

Roof Panel - End Lap Joint

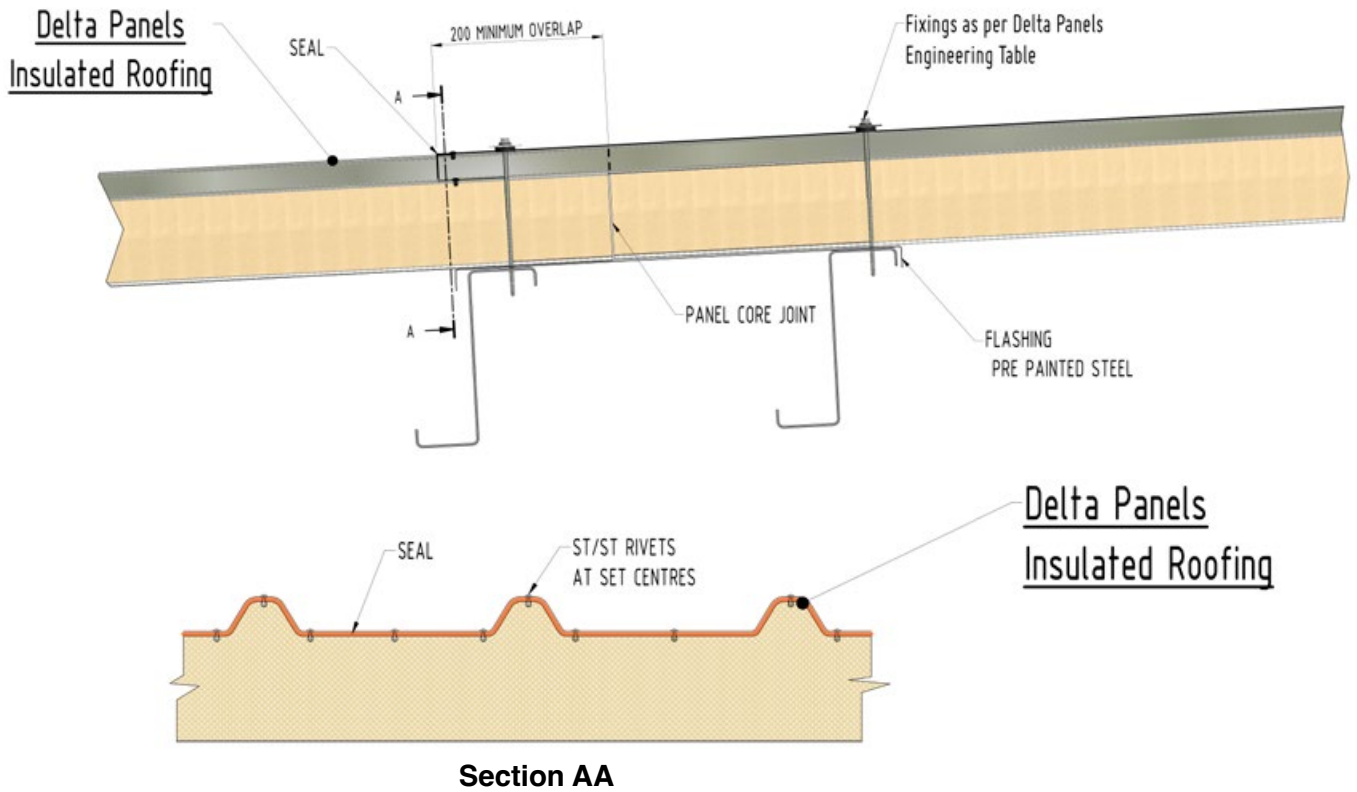

Roof Panel - Step Joint

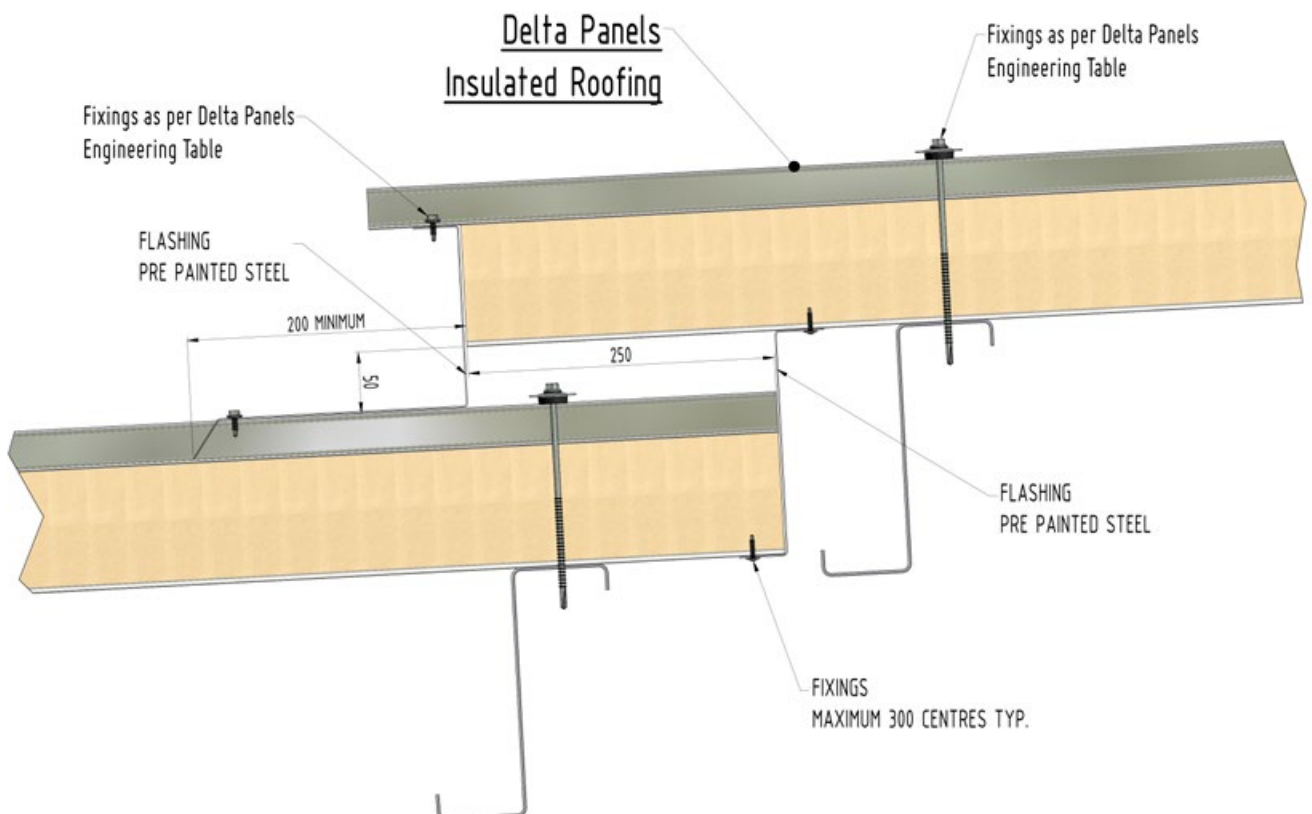

14. INSTALLATION - CONNECTION DETAILS

Roof Panel - Ridge Capping Details

Delta Panels
Insulated Roofing

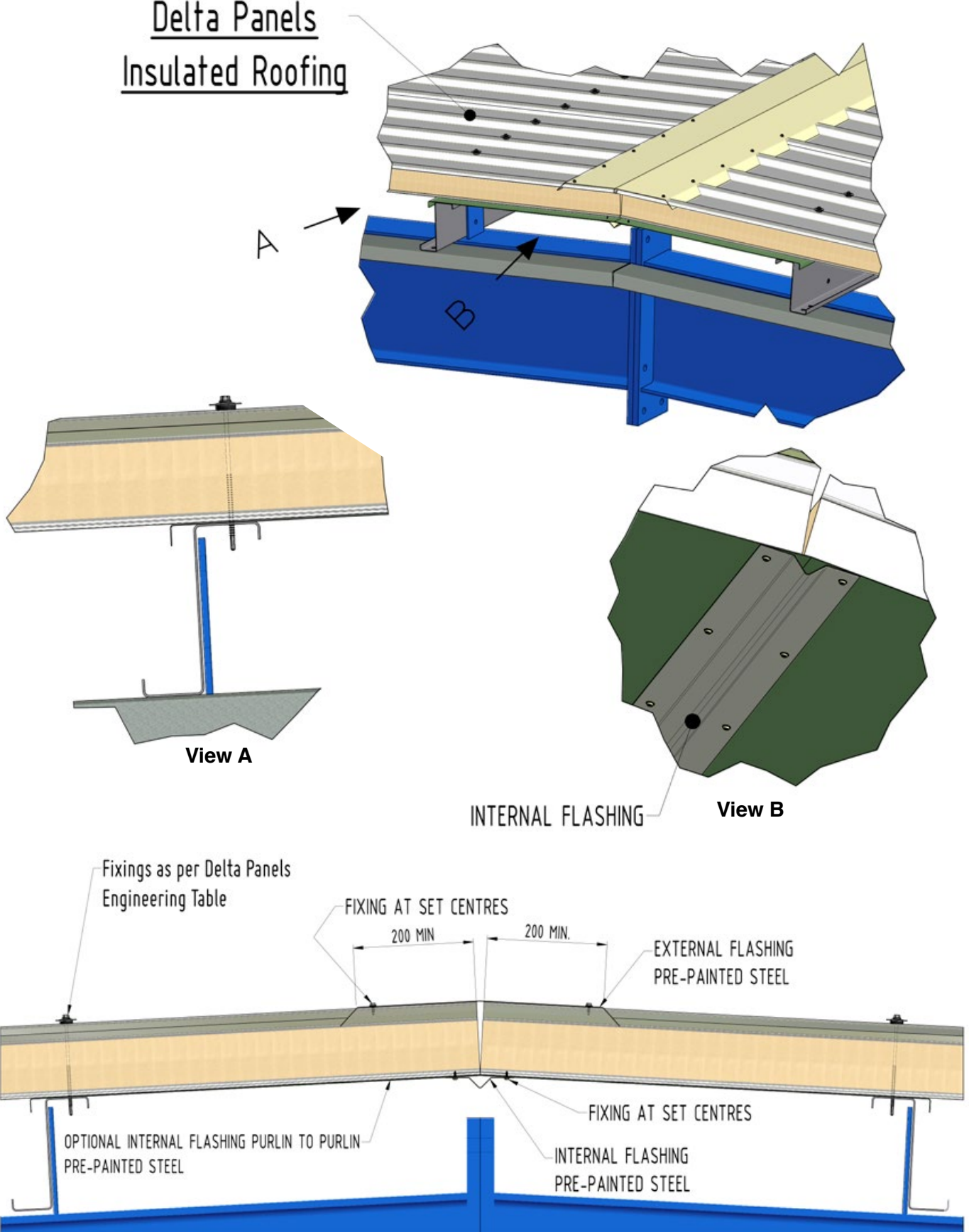

14. INSTALLATION - CONNECTION DETAILS

Roof Panel - Standard Connection - DeltaTrim

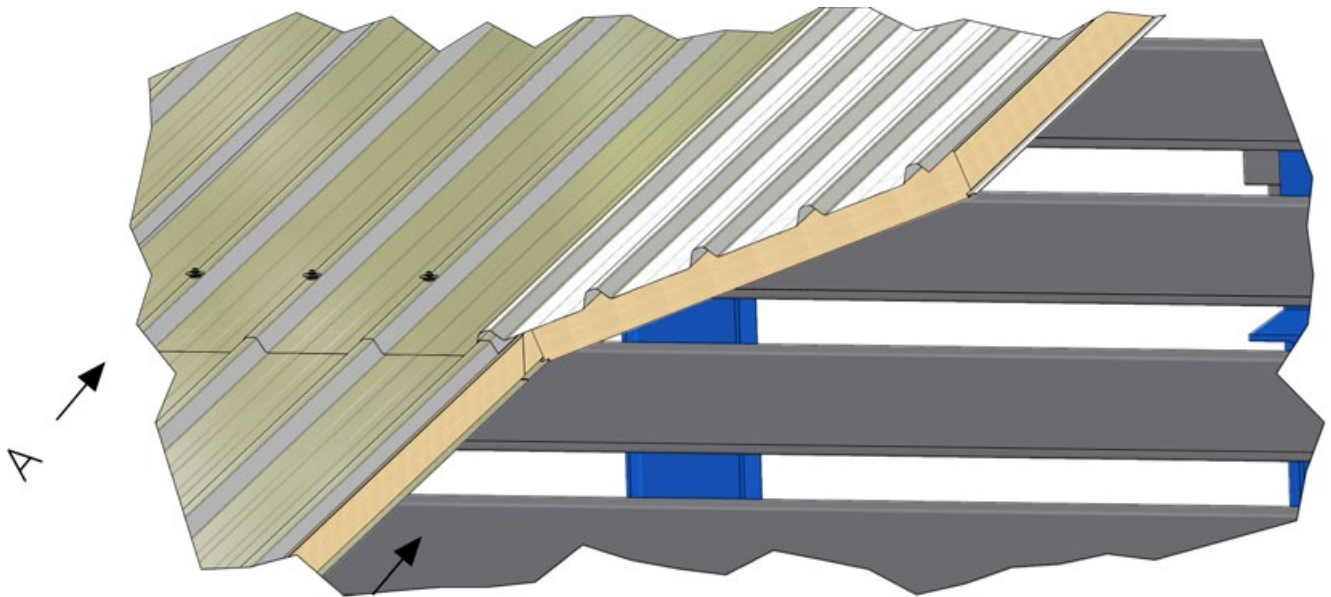

POP RIVETS
AT SET CENTRES

Fixings as per Delta Panels
Engineering Table

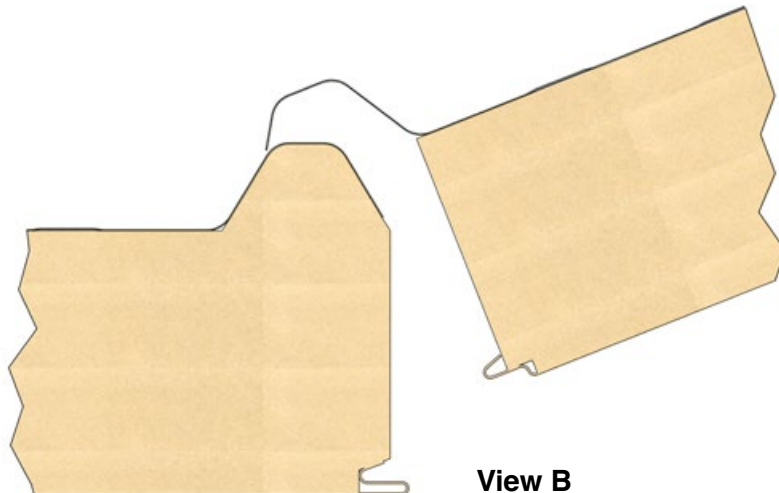
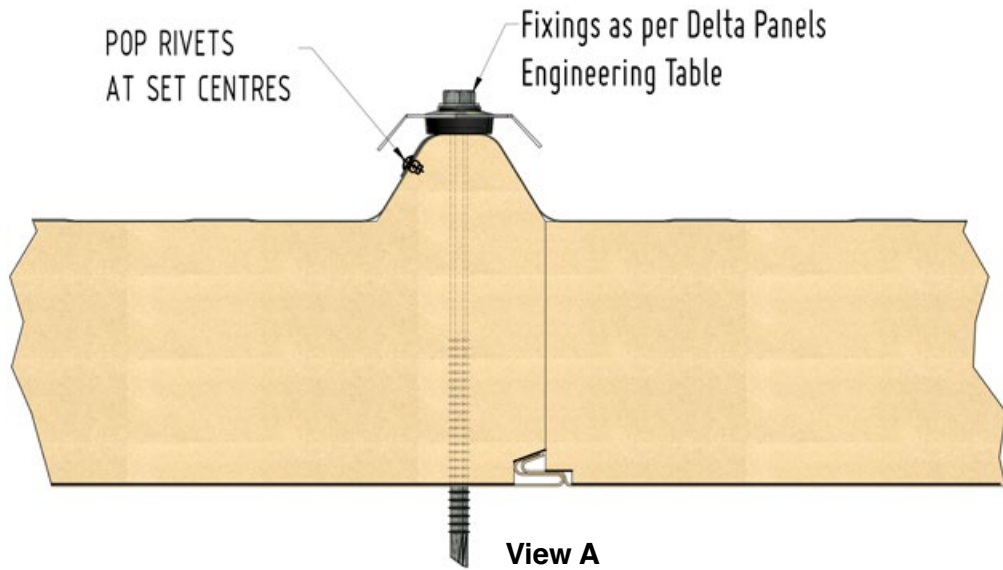

14. INSTALLATION - CONNECTION DETAILS

Roof Panel - Standard Connection - DeltaOrb

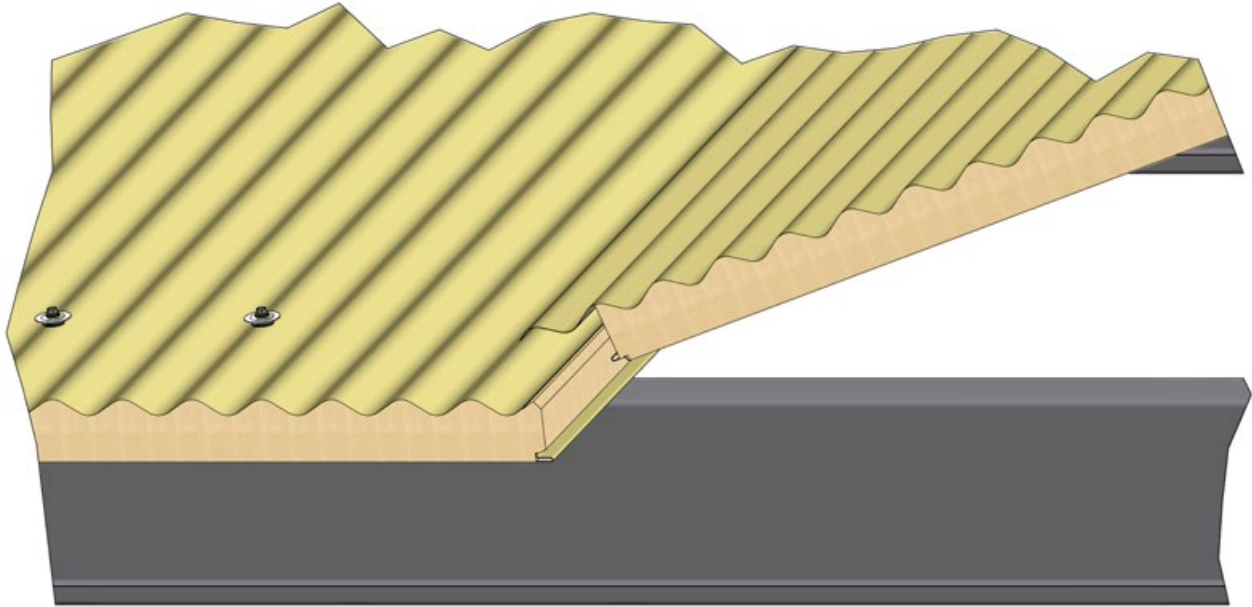

Fixings as per Delta Panels
Engineering Table

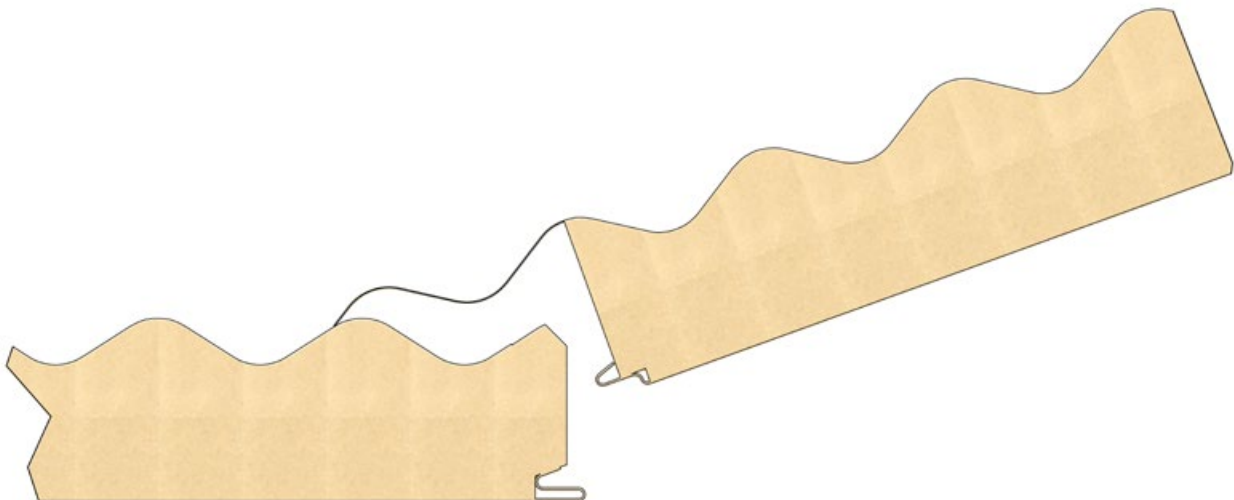
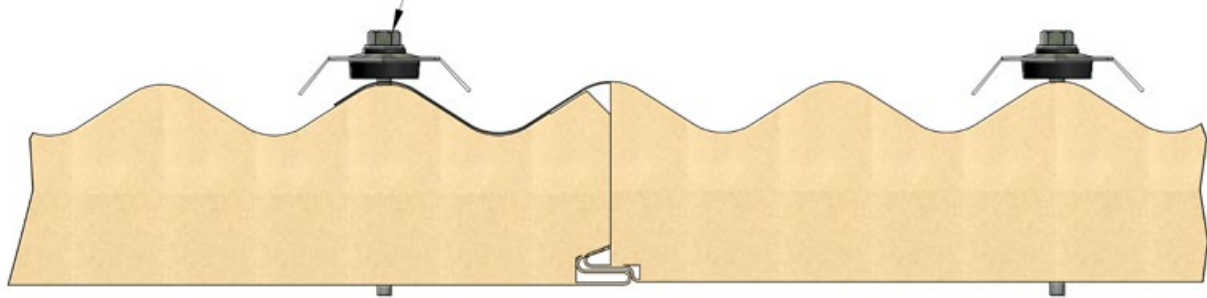

14. INSTALLATION - CONNECTION DETAILS

Roof Panel - Standard Connection - DeltaCorroCorro

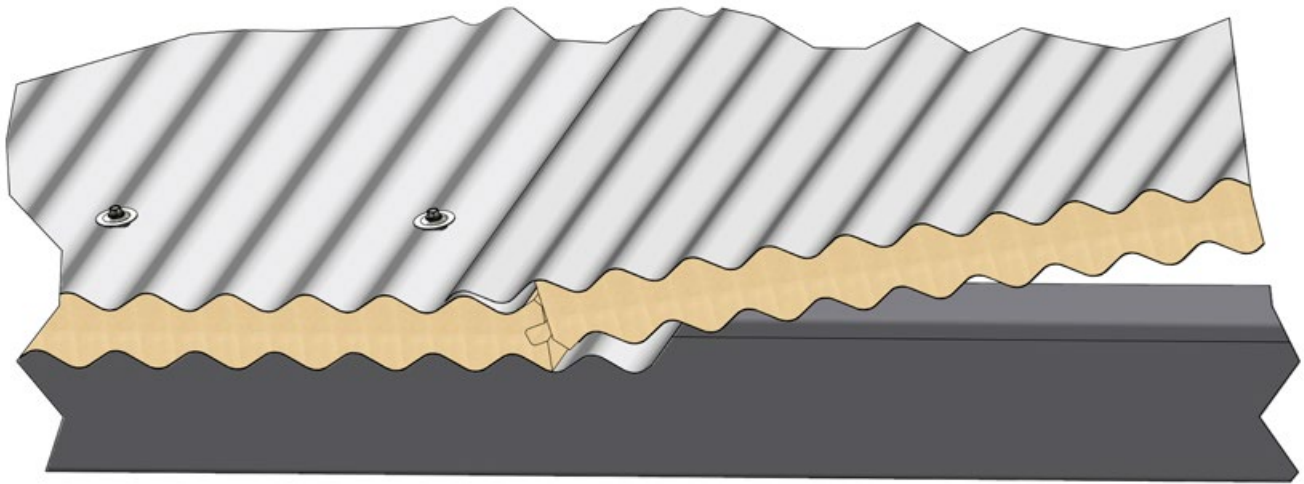

Fixings as per Delta Panels Engineering Table

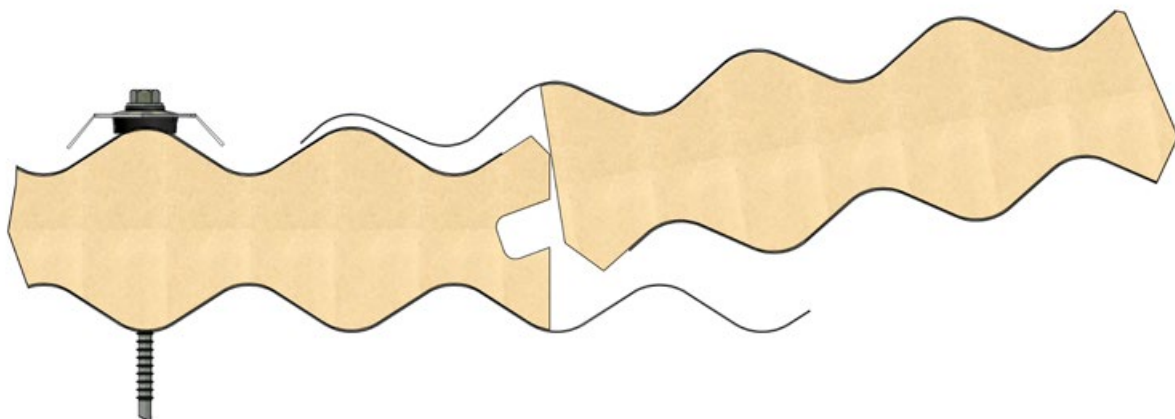
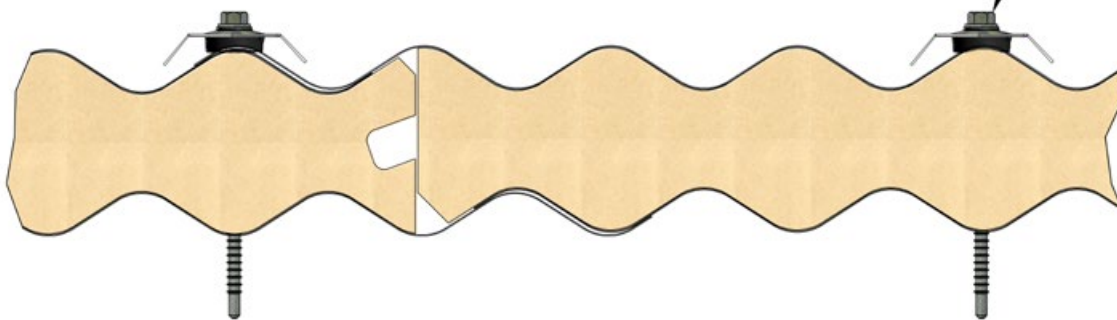

14. INSTALLATION - CONNECTION DETAILS

Roof Panel - Standard Connection - DeltaTrimTrim

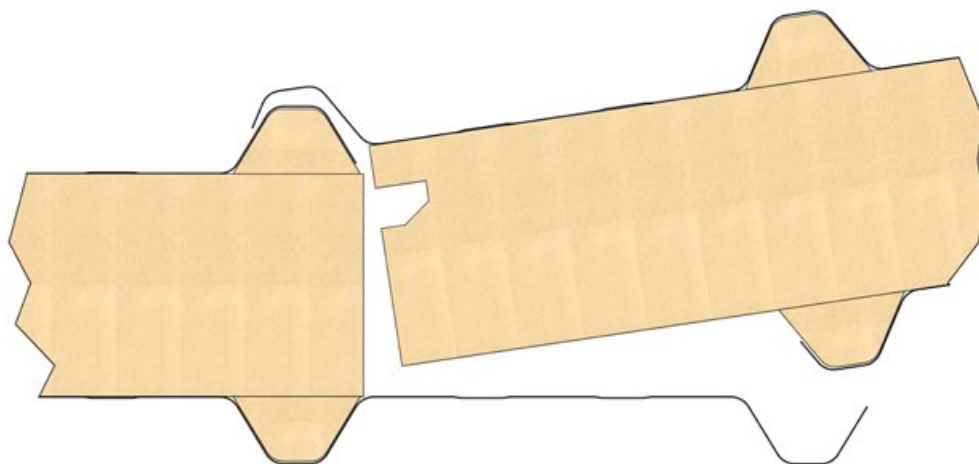
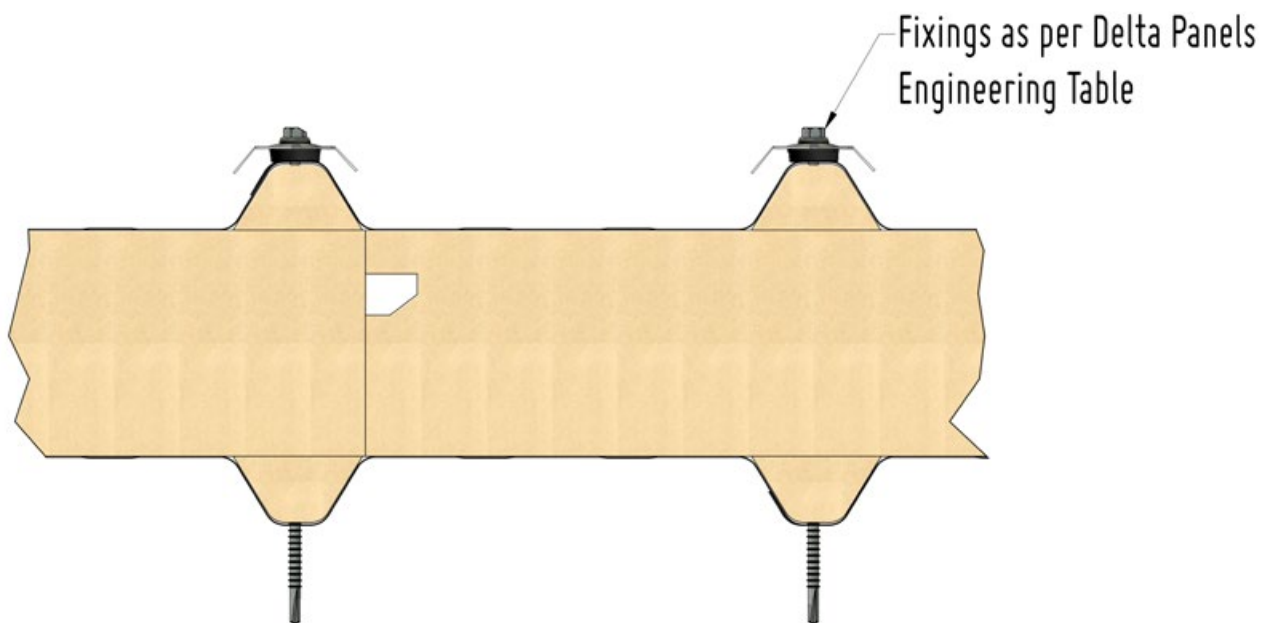
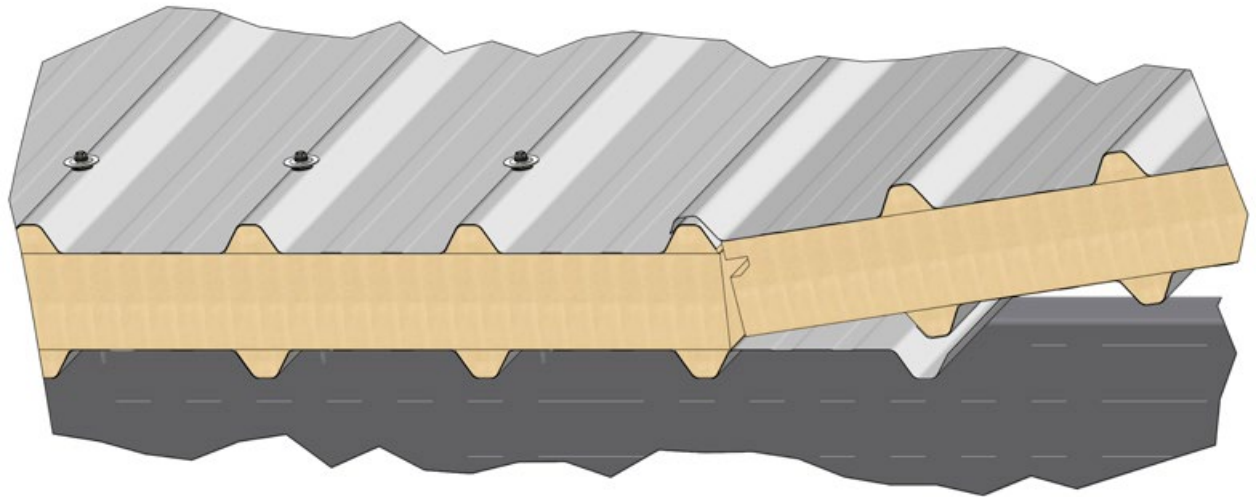

14. INSTALLATION - CONNECTION DETAILS

Roof Panel - Standard Connection - DeltaTrimCorro

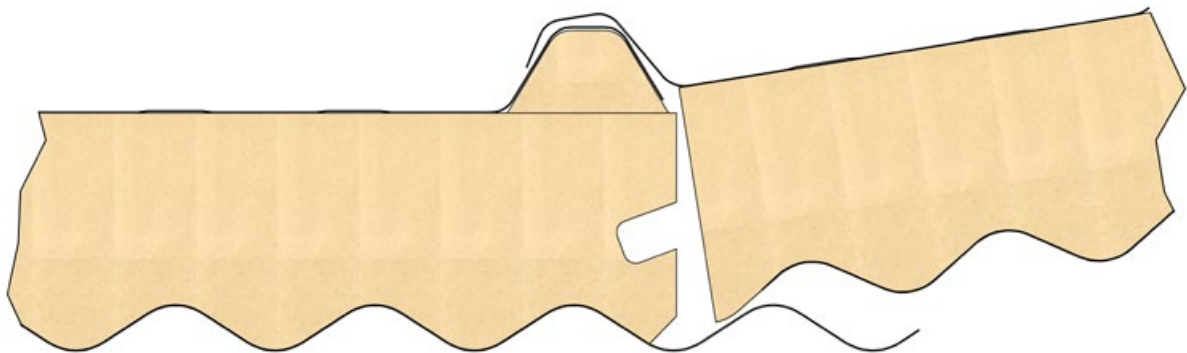
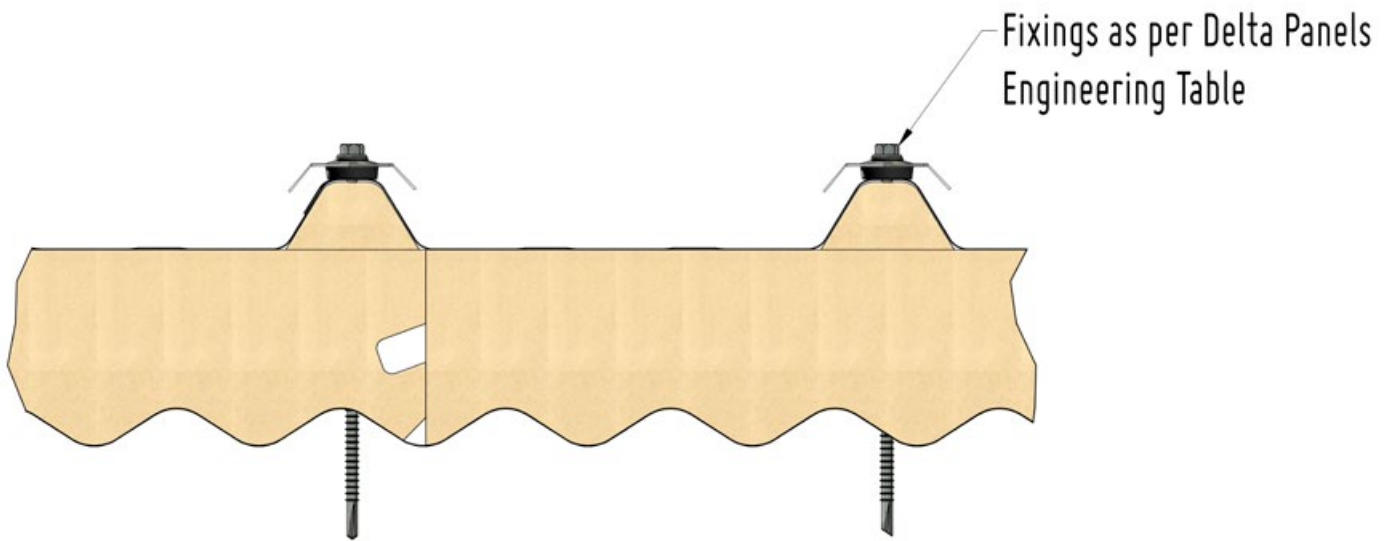
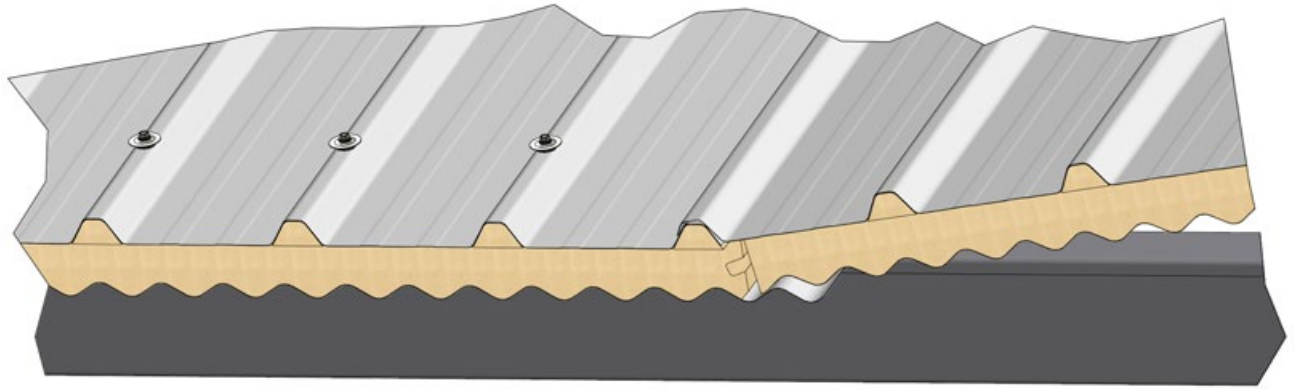

14. INSTALLATION - CONNECTION DETAILS

Roof Panel - Thermal Stress Cut & Fixing

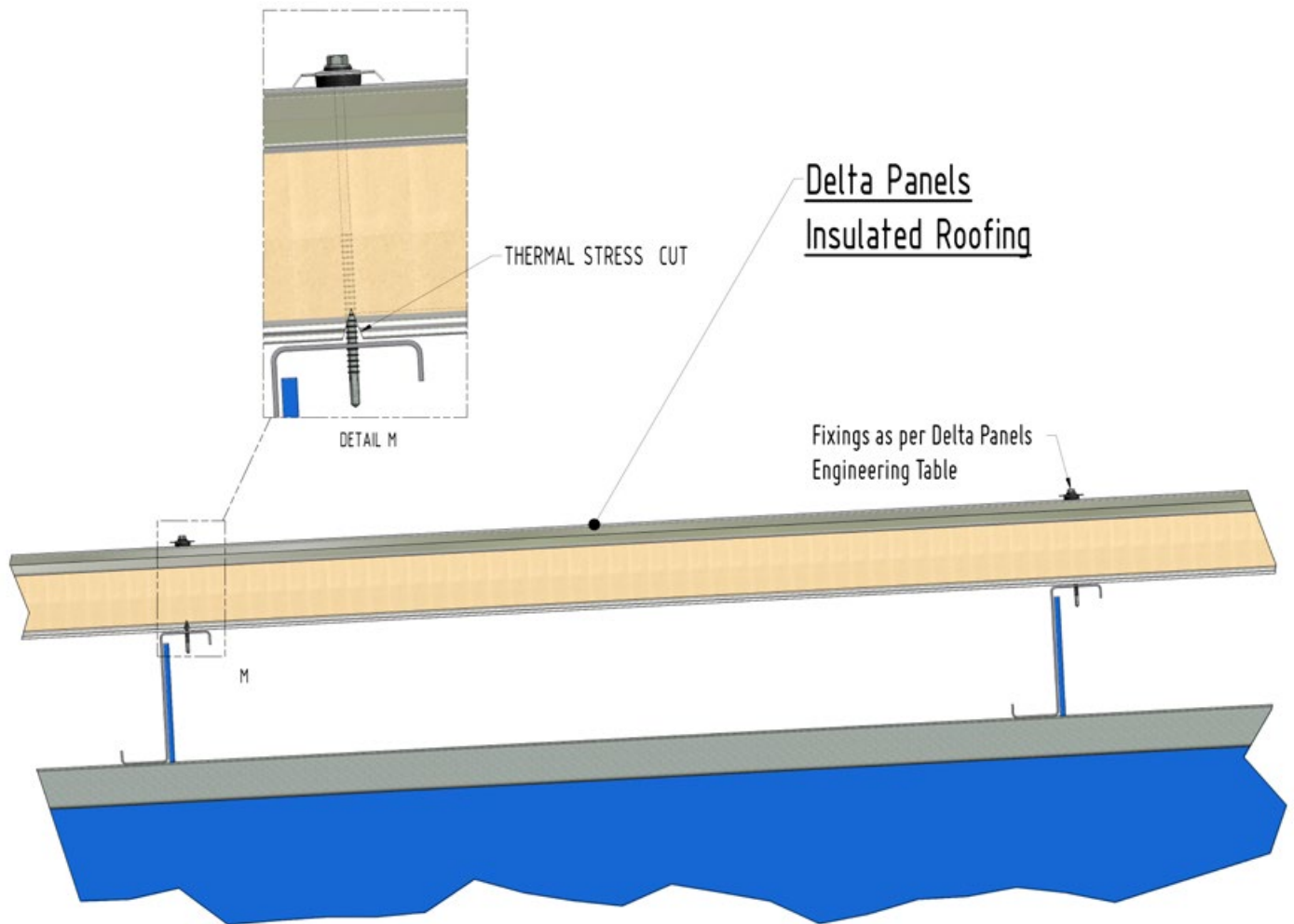

14. INSTALLATION - CONNECTION DETAILS

Gutter to Roof Connection - For Overhang Roof

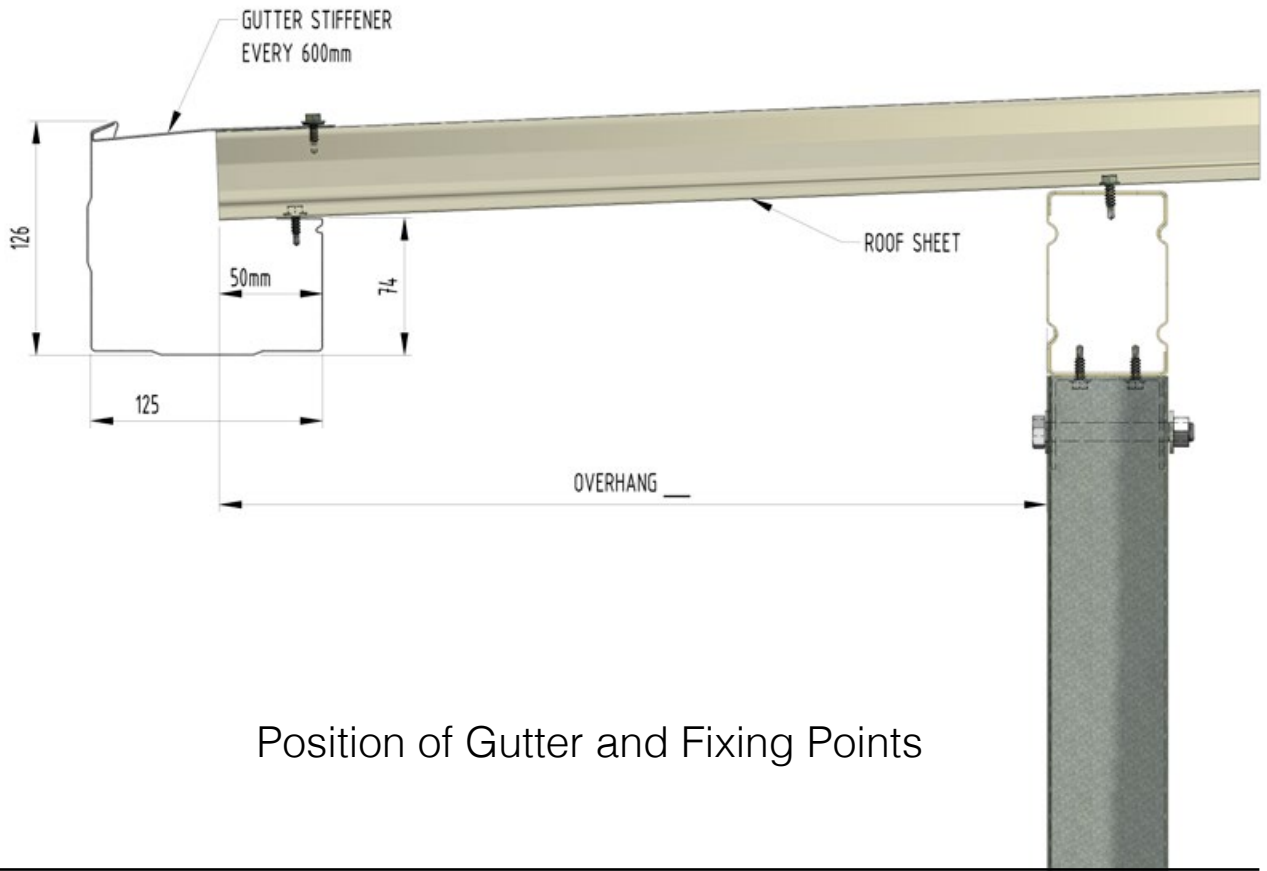

Position of Gutter and Fixing Points

Gutter to Roof Connection - Gutter Attachment

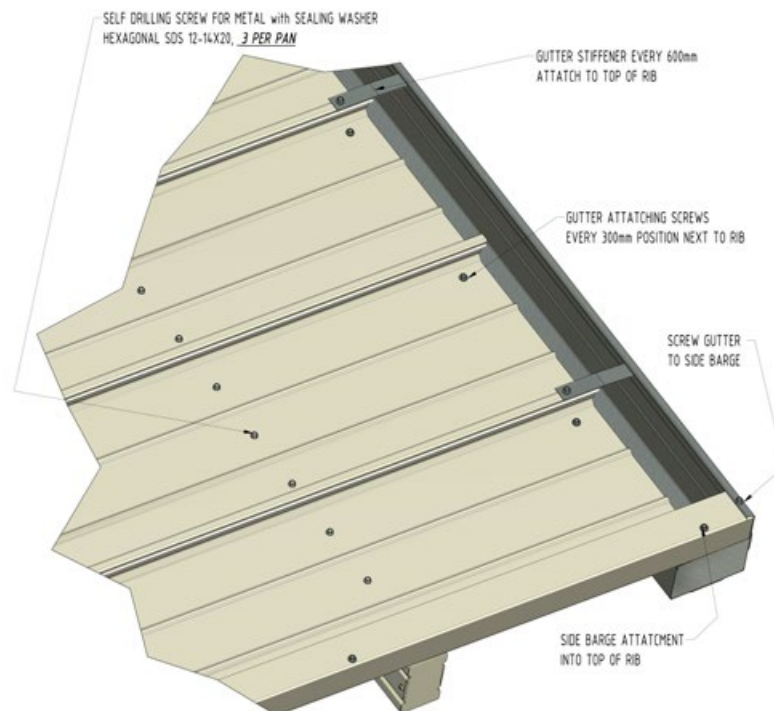

Gutter attachment to Roof, with Stiffener Straps

14. INSTALLATION - CONNECTION DETAILS

Gutter to Roof Connection - Finished Assembly

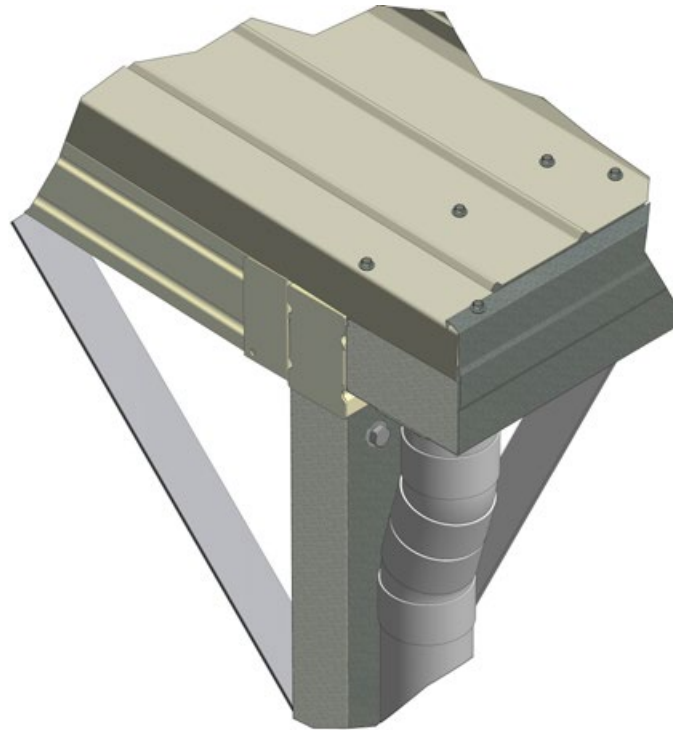

Finished Gutter Assembly - Downpipe End

Gutter to Roof Connection - Finished Assembly

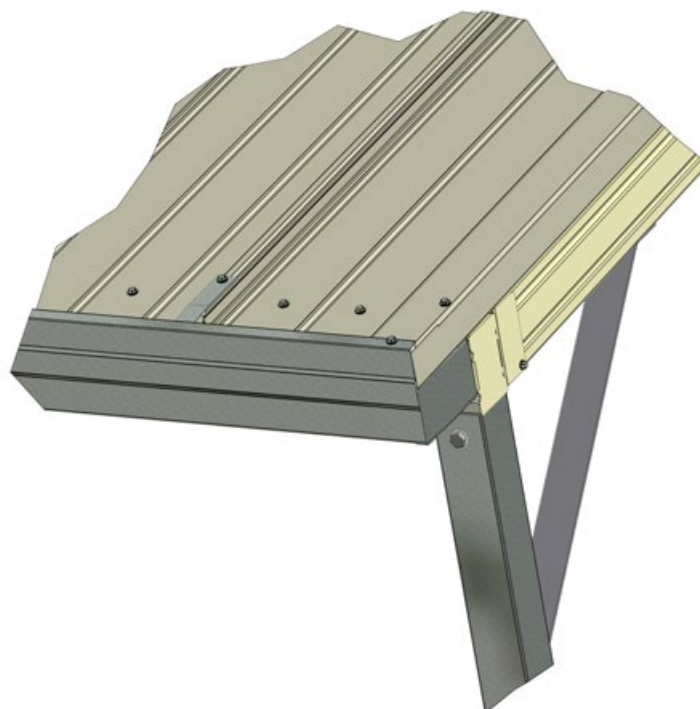

Finished Gutter Assembly - Non-Downpipe End

15. INSTALLATION - FLASHINGS

DeltaSingle™

DeltaSingle Receiver Channel

MATERIAL: 0.95mm BMT

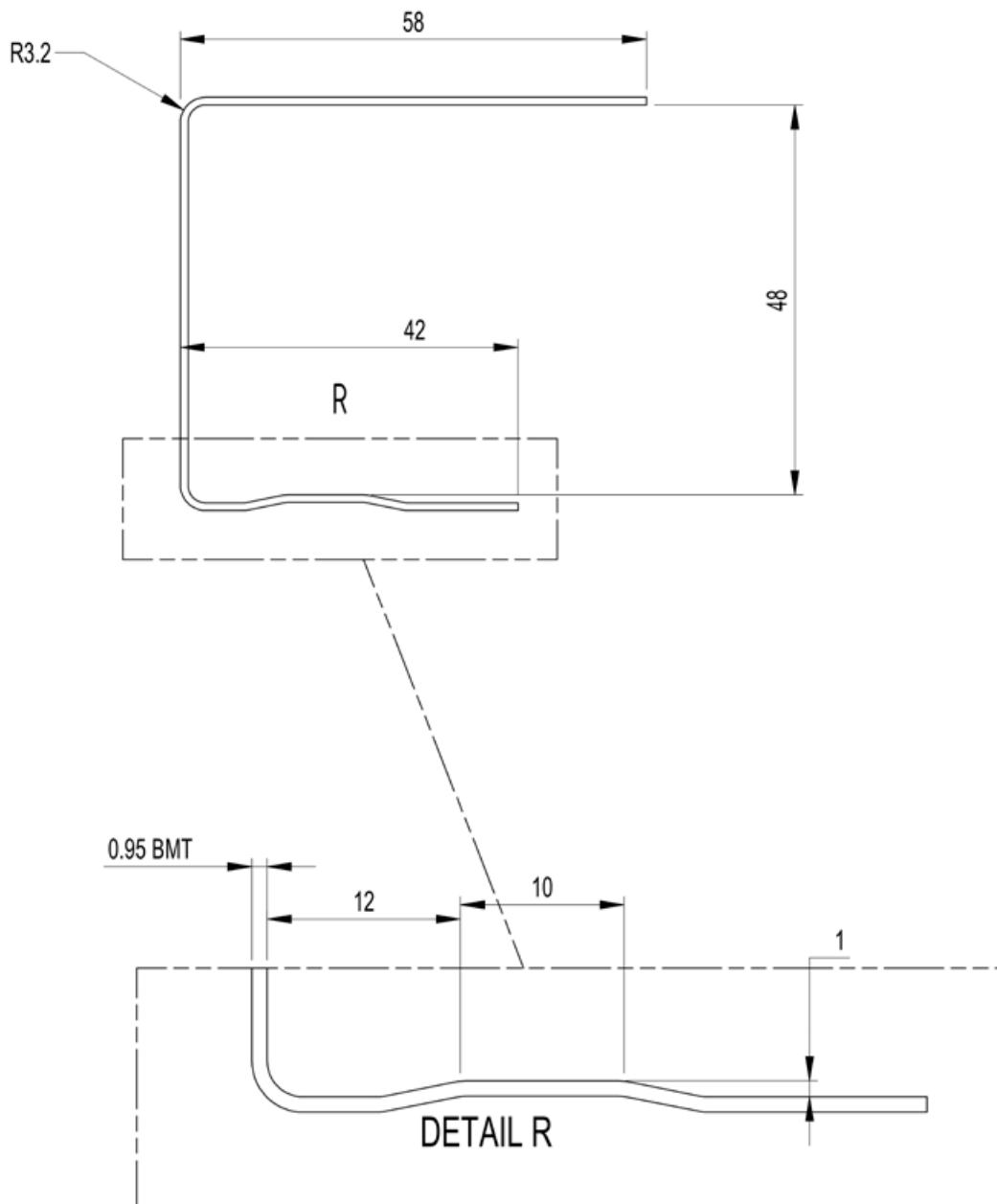

15. INSTALLATION - FLASHINGS

DeltaSingle™

DeltaSingle Side Channel

MATERIAL: 0.55mm G300

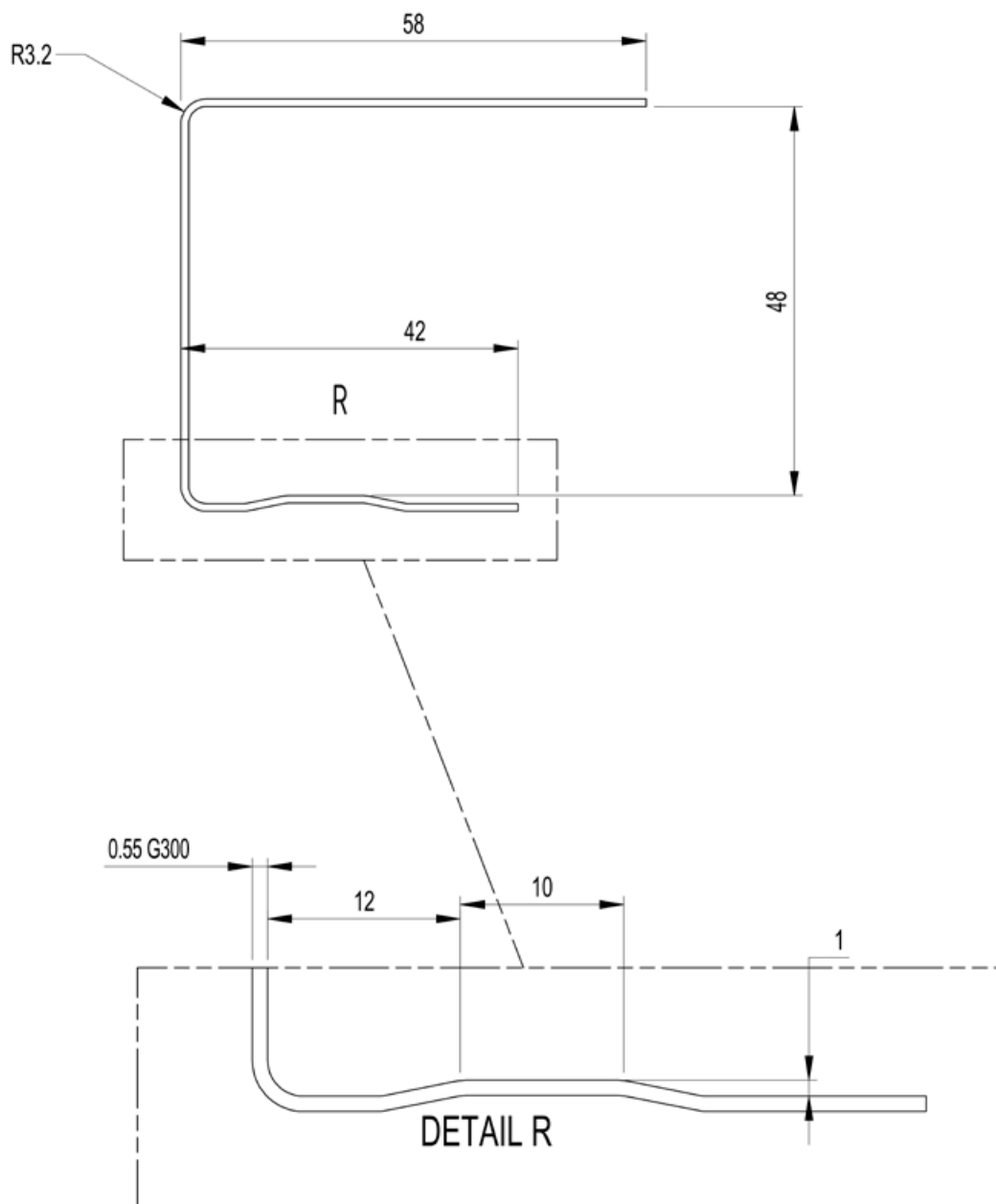

15. INSTALLATION - FLASHINGS

DeltaTrim™

DeltaTrim Receiver Channel

MATERIAL: 1.2mm

L=NUMBER OF PANELS +50mm

THICKNESS	D
50mm	87
75mm	112
100mm	137
125mm	162
150mm	187
175mm	212
200mm	237

ROOF PITCH FOR THIS ORDER		
ANGLE	STD	REQD
A	2°°

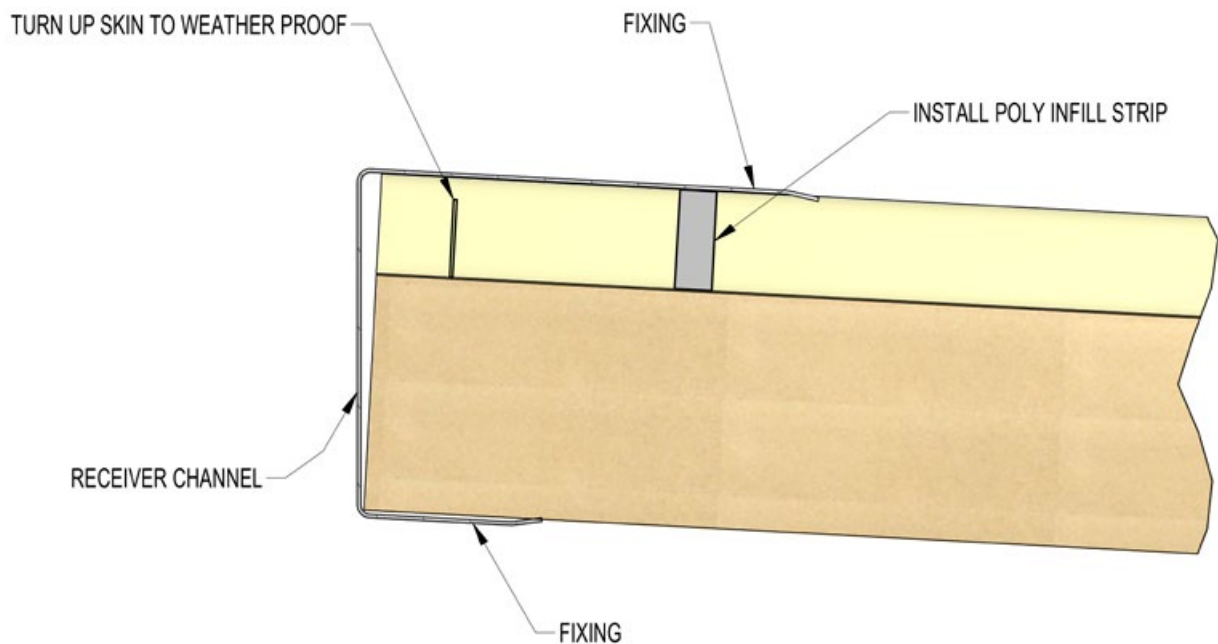
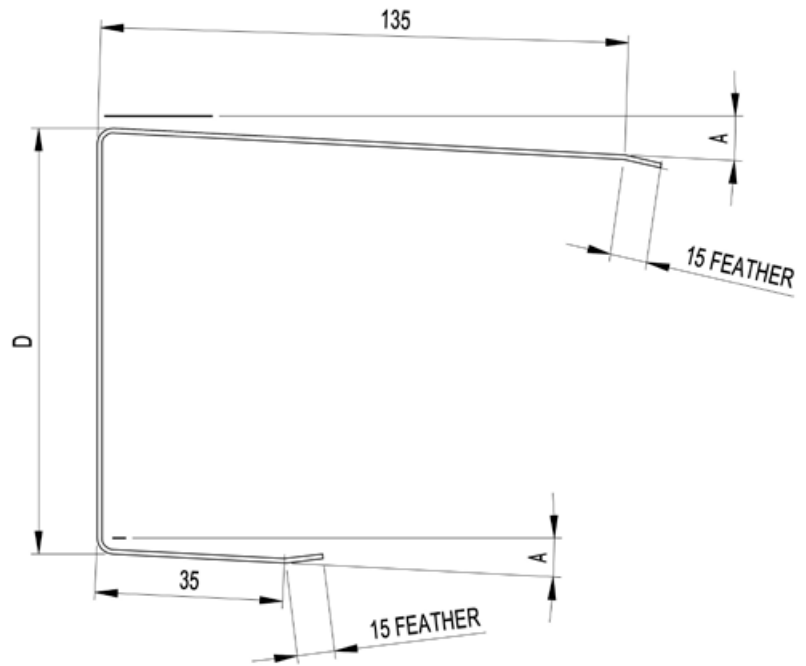

Receiver Channel Assembly Detail

Flashing must be fitted in accordance with the relevant standard.

15. INSTALLATION - FLASHINGS

DeltaTrim™

DeltaTrim Receiver Channel Flashing

MATERIAL: 0.55mm G300

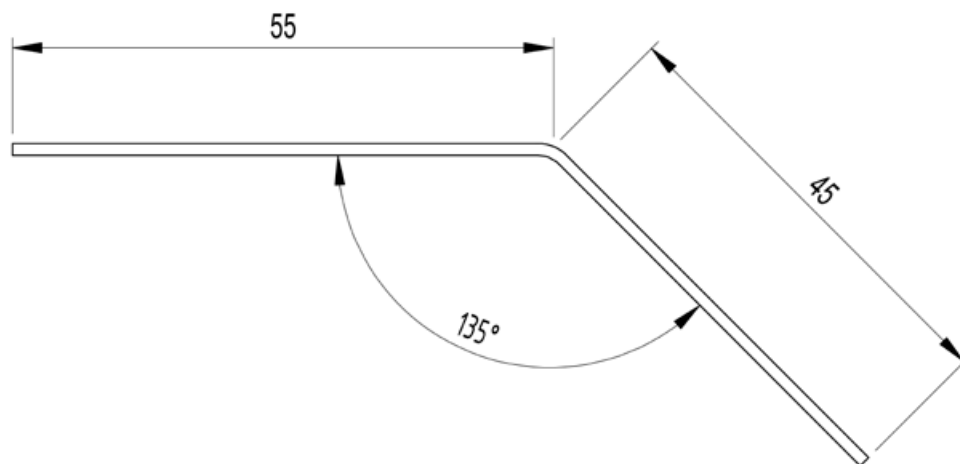

$L = \text{NUMBER OF PANELS} + 50\text{mm}$

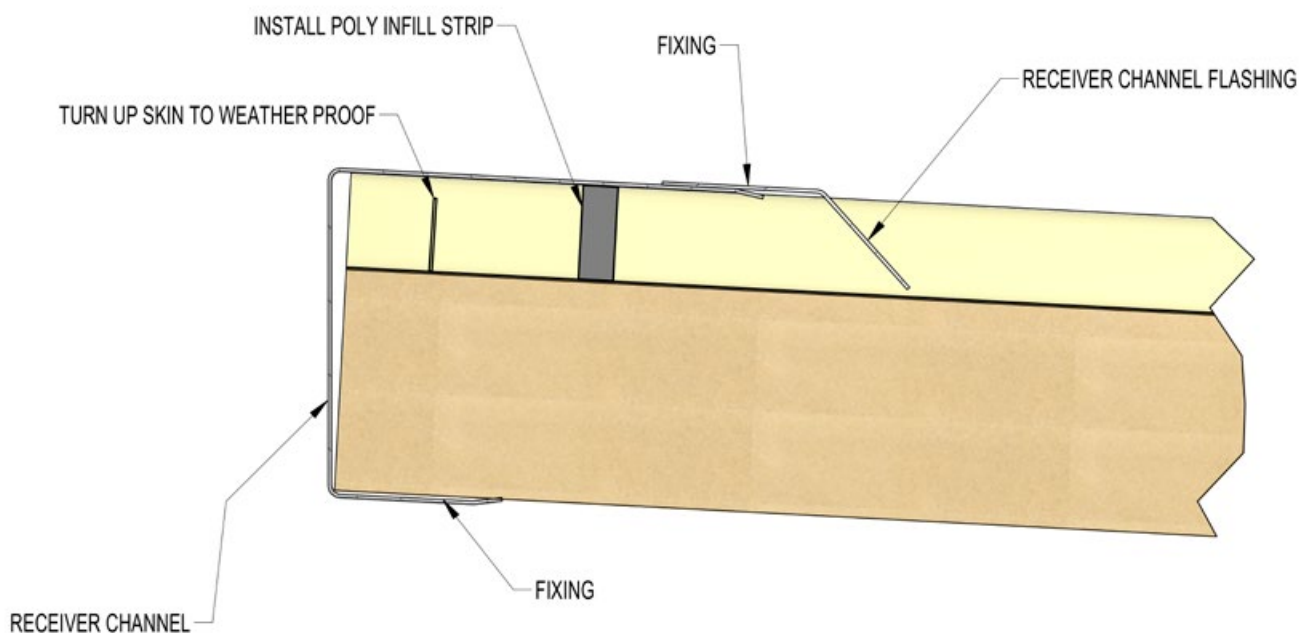

Receiver Channel Assembly Detail

Flashing must be fitted in accordance with the relevant standard.

15. INSTALLATION - FLASHINGS

DeltaTrim™

DeltaTrim Apron Flashing

MATERIAL: 0.55mm G300

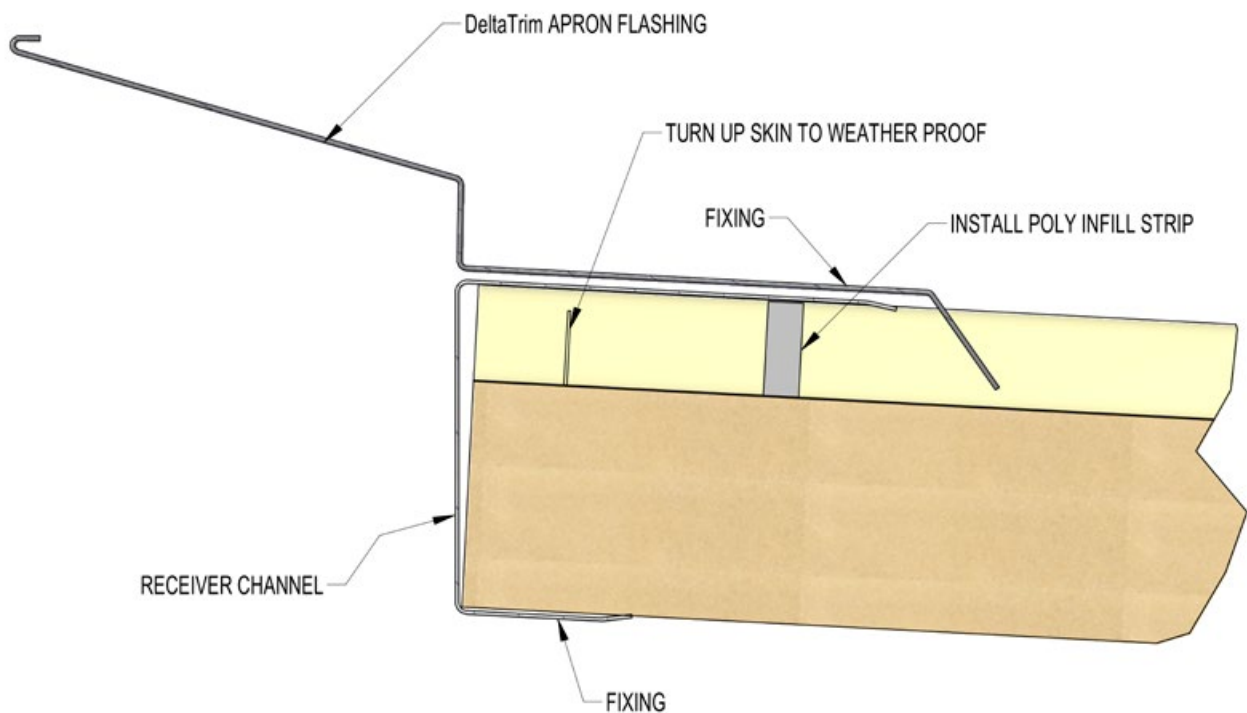
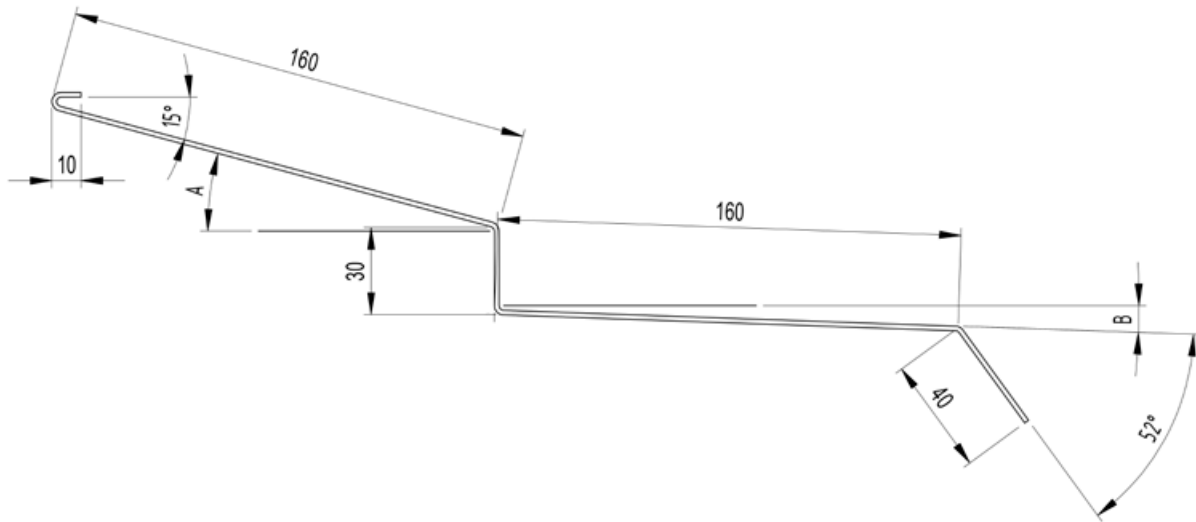

Apron Flashing Assembly

Flashing must be fitted in accordance with the relevant standard.

15. INSTALLATION - FLASHINGS

DeltaTrim™

DeltaTrim Apron Flashing - B

MATERIAL: 0.55mm G300

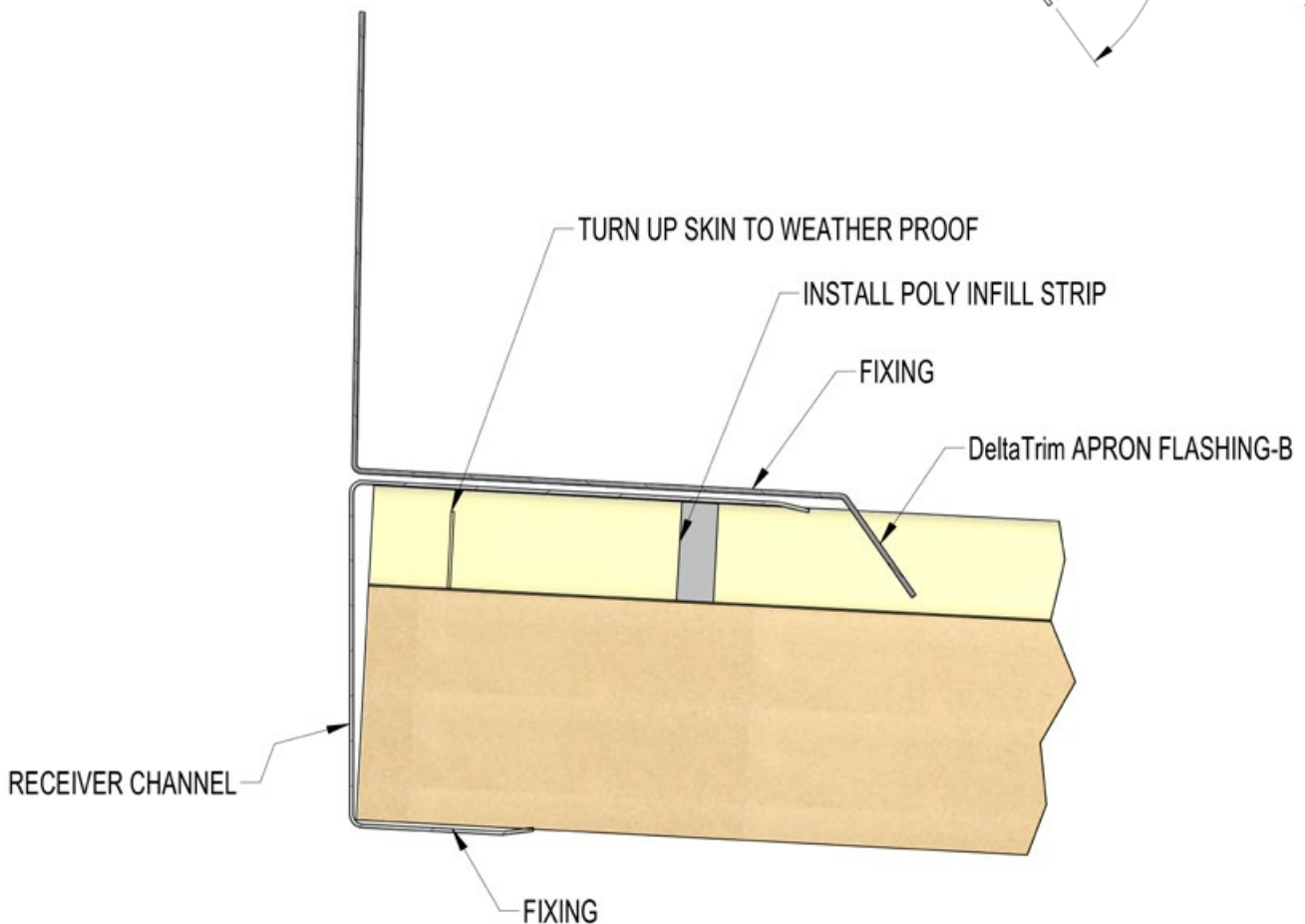
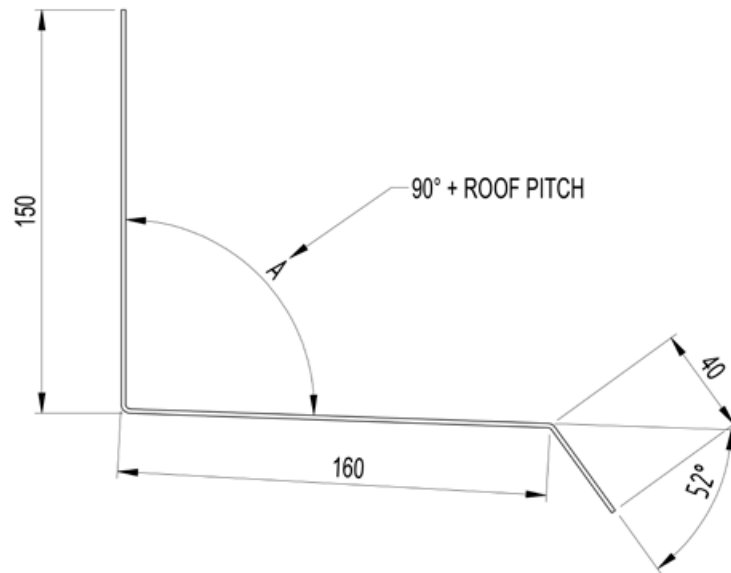

Apron Flashing-B Assembly Detail

Flashing must be fitted in accordance with the relevant standard.

15. INSTALLATION - FLASHINGS

DeltaTrim™

DeltaTrim Ridge Cap

MATERIAL: 0.55mm G300

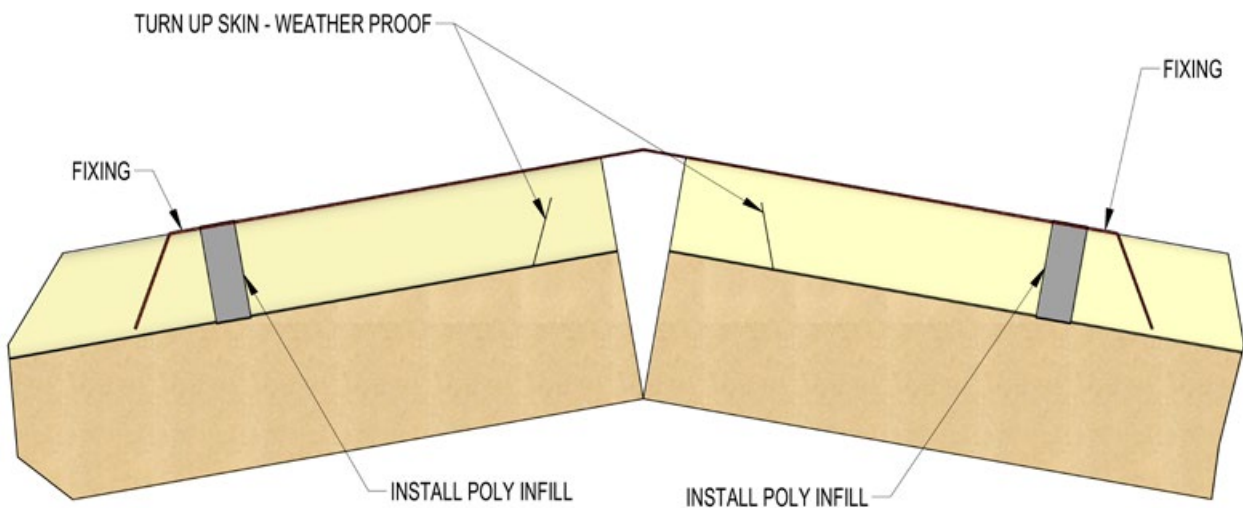
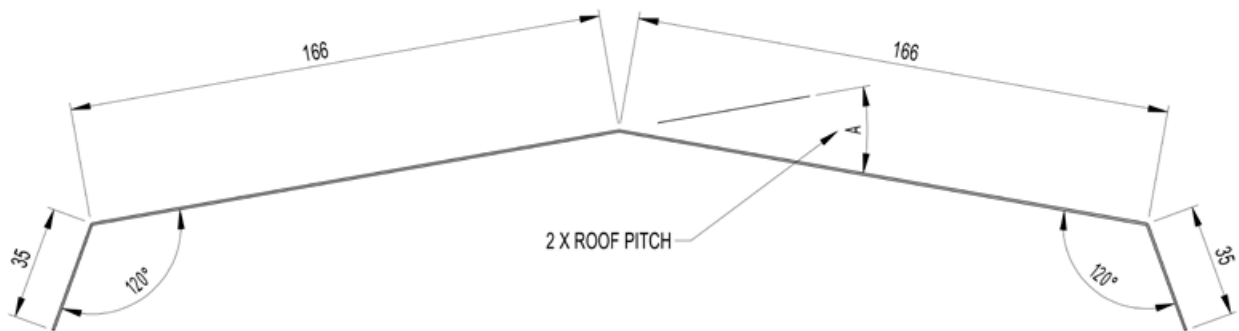

Ridge Cap Fixing Assembly Detail

15. INSTALLATION - FLASHINGS

DeltaTrim™

DeltaTrim Side Barge Capping

MATERIAL: 0.55mm G300



THICKNESS	D
50mm	87
75mm	112
100mm	137
125mm	162
150mm	187
175mm	212
200mm	237

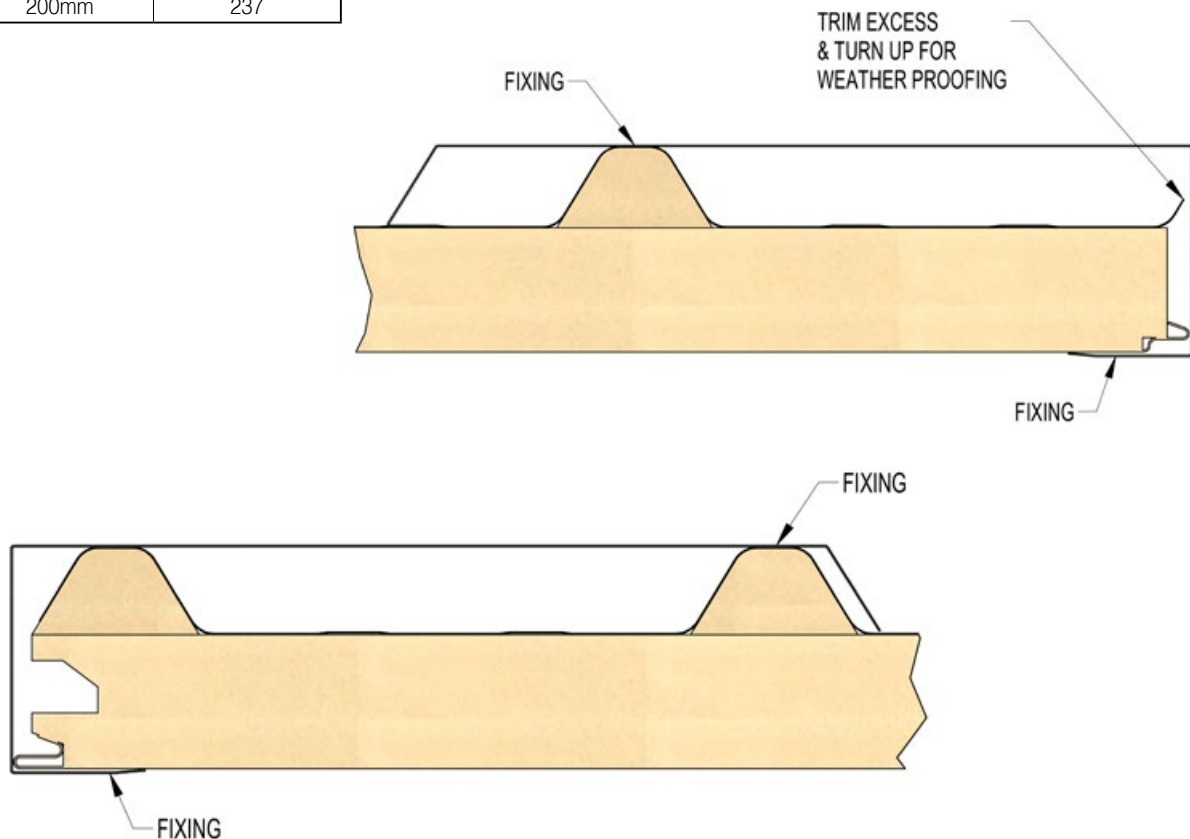

Side Barge Capping Assembly Detail

Flashing must be fitted in accordance with the relevant standard.

15. INSTALLATION - FLASHINGS

DeltaTrim™

DeltaTrim Side Barge Capping with Drip Guard

MATERIAL: 0.55mm G300



THICKNESS	D
75mm	137
100mm	162
125mm	187
150mm	212
175mm	237
200mm	262

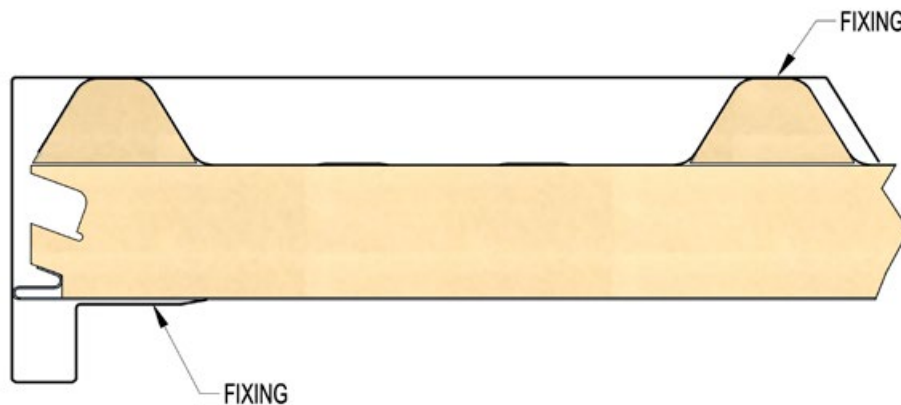
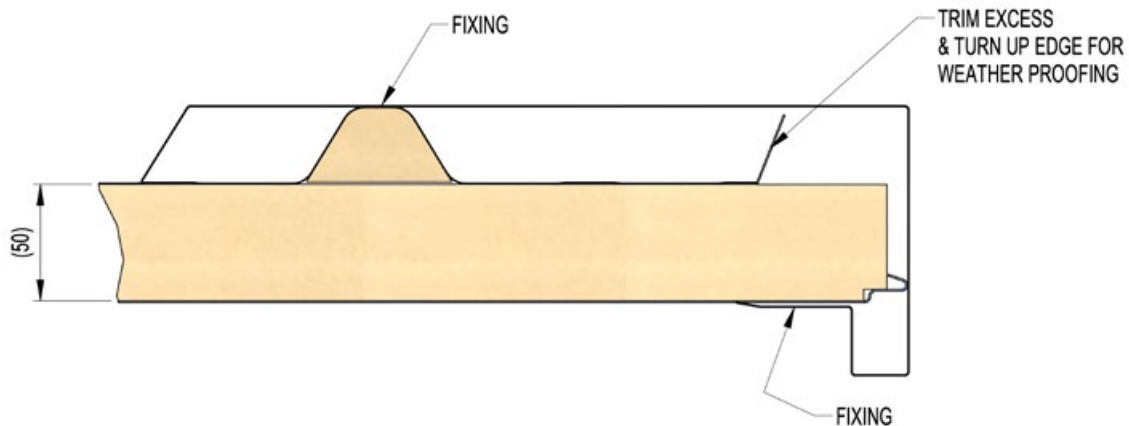
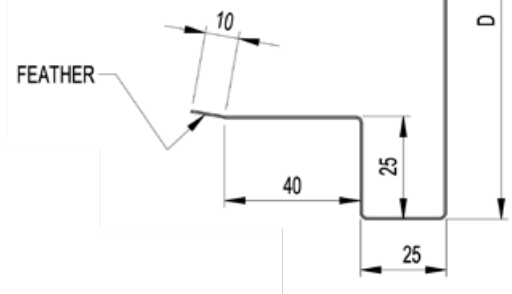

Side Barge Capping Assembly Detail

Flashing must be fitted in accordance with the relevant standard.

15. INSTALLATION - FLASHINGS

DeltaTrim™

DeltaTrim Side Barge with Drip Guard - 50mm Only

MATERIAL: 0.55mm G300

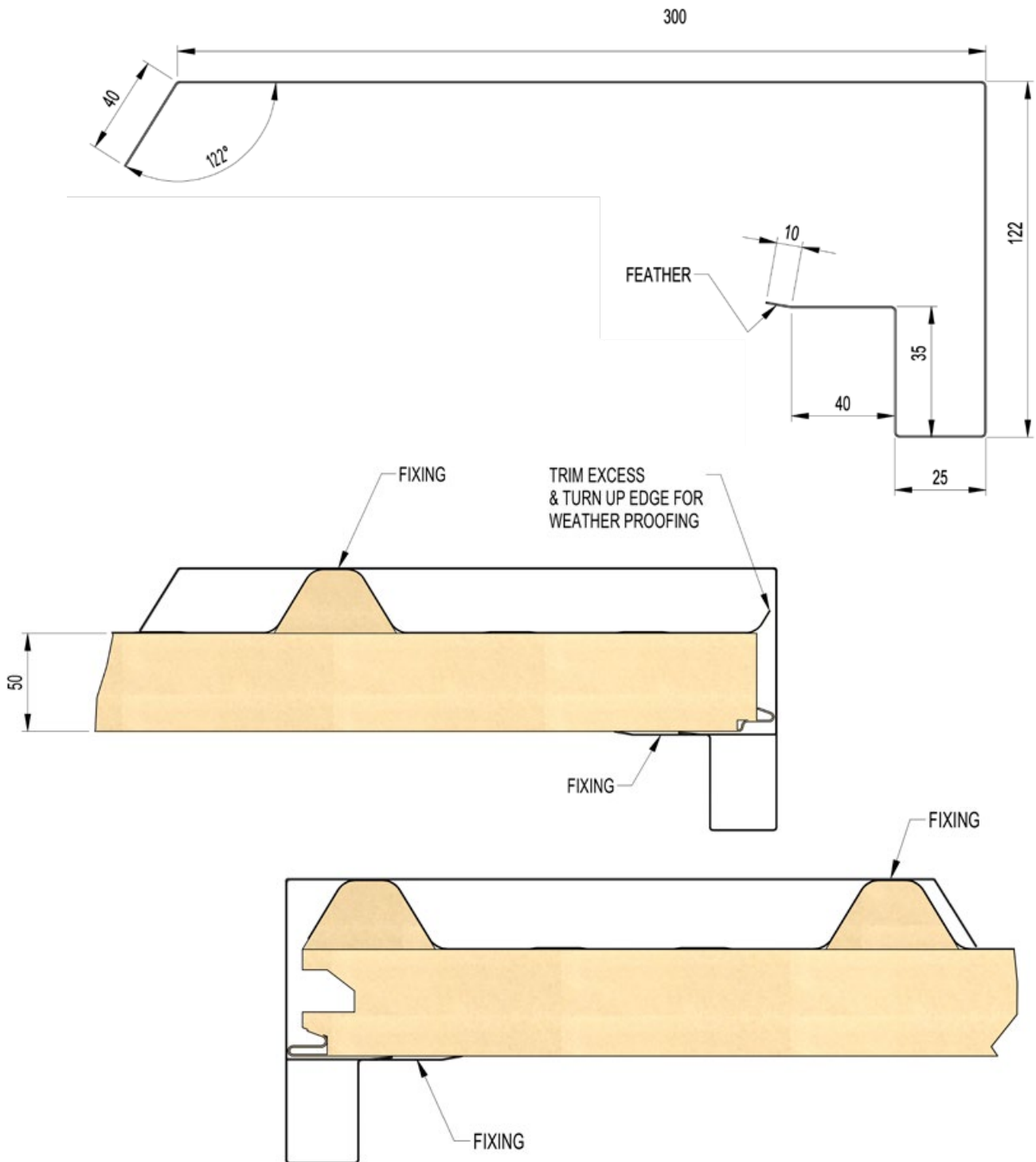

Side Barge Assembly Detail

15. INSTALLATION - FLASHINGS

DeltaTrim™

DeltaTrim Rear Barge Capping

MATERIAL: 0.55mm G300

THICKNESS	D
50mm	87
75mm	112
100mm	137
125mm	162
150mm	187
175mm	212
200mm	237

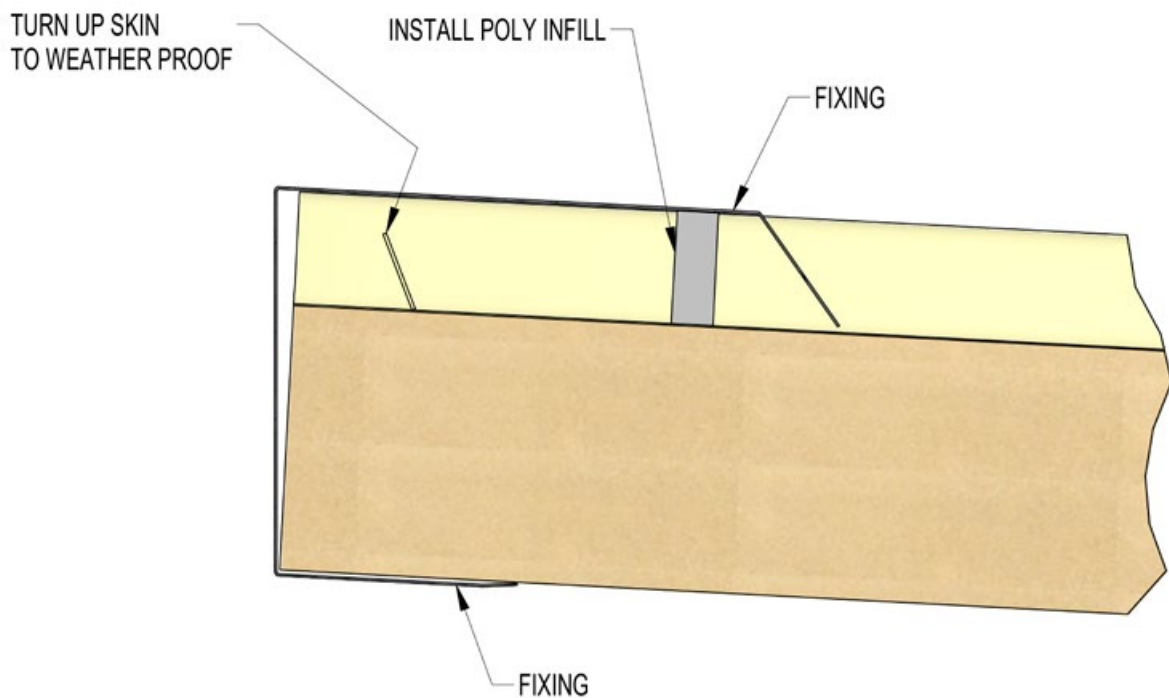
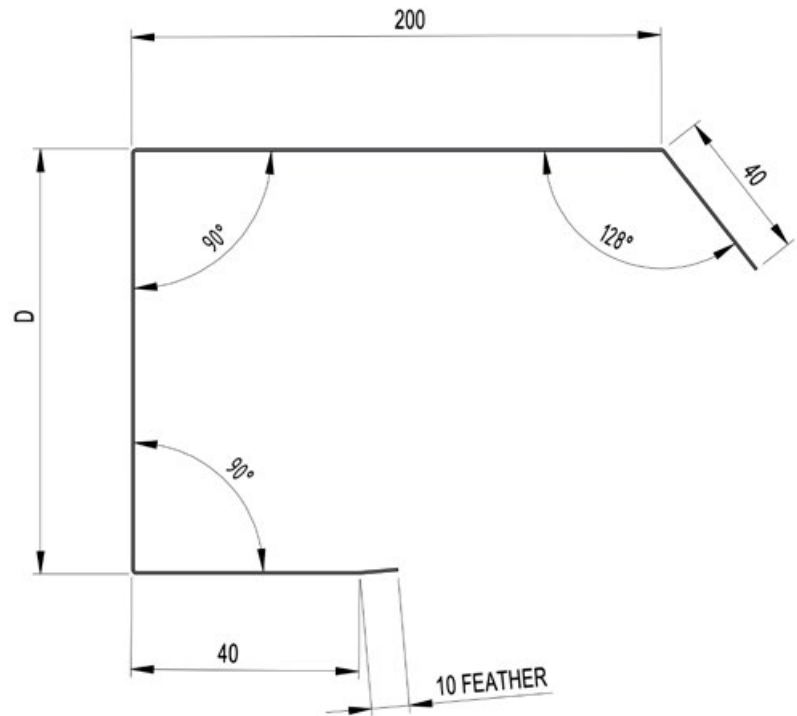

Rear Barge Capping Assembly Detail

15. INSTALLATION - FLASHINGS

DeltaTrim™

DeltaTrim Rear Barge Capping with Drip Guard

MATERIAL: 0.55mm G300

THICKNESS	D
75mm	137
100mm	162
125mm	187
150mm	212
175mm	237
200mm	262

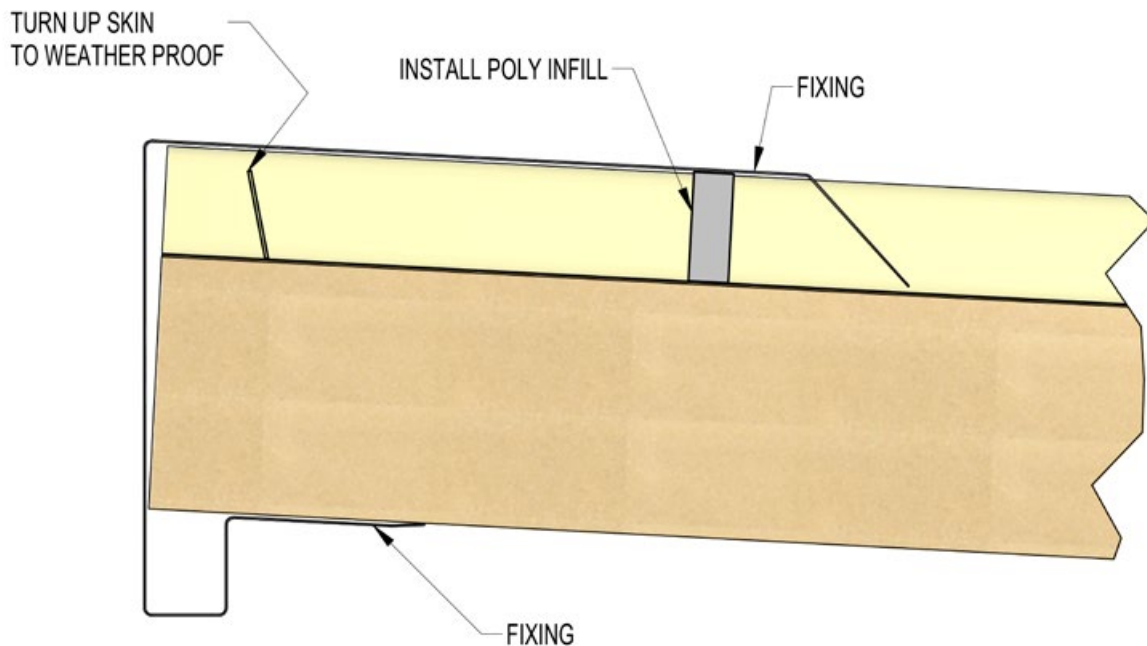
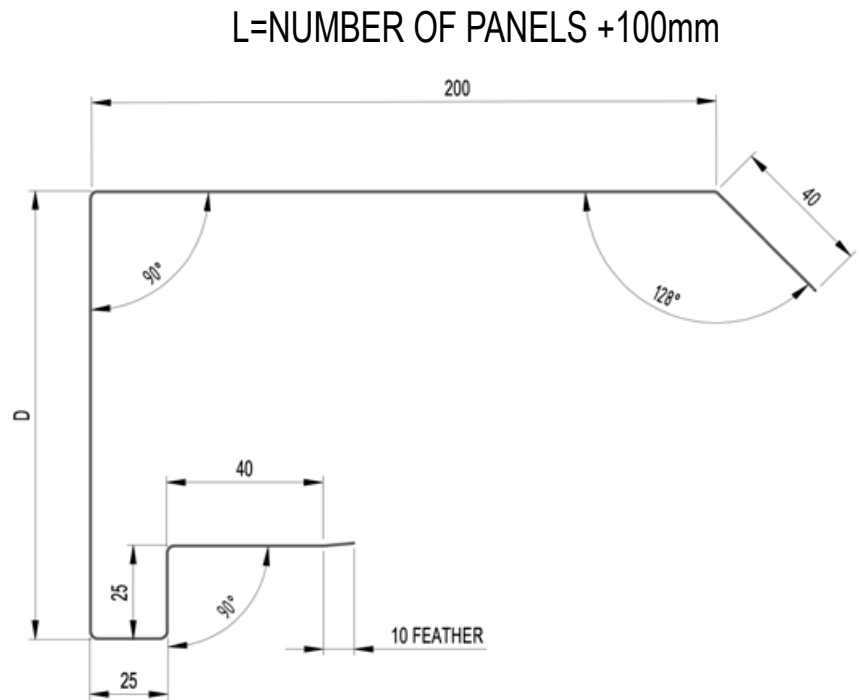

Rear Barge Capping Assembly Detail

Flashing must be fitted in accordance with the relevant standard.

15. INSTALLATION - FLASHINGS

DeltaTrim™

DeltaTrim Rear Barge Capping - 50mm Only

MATERIAL: 0.55mm G300

$L = \text{NUMBER OF PANELS} + 100\text{mm}$

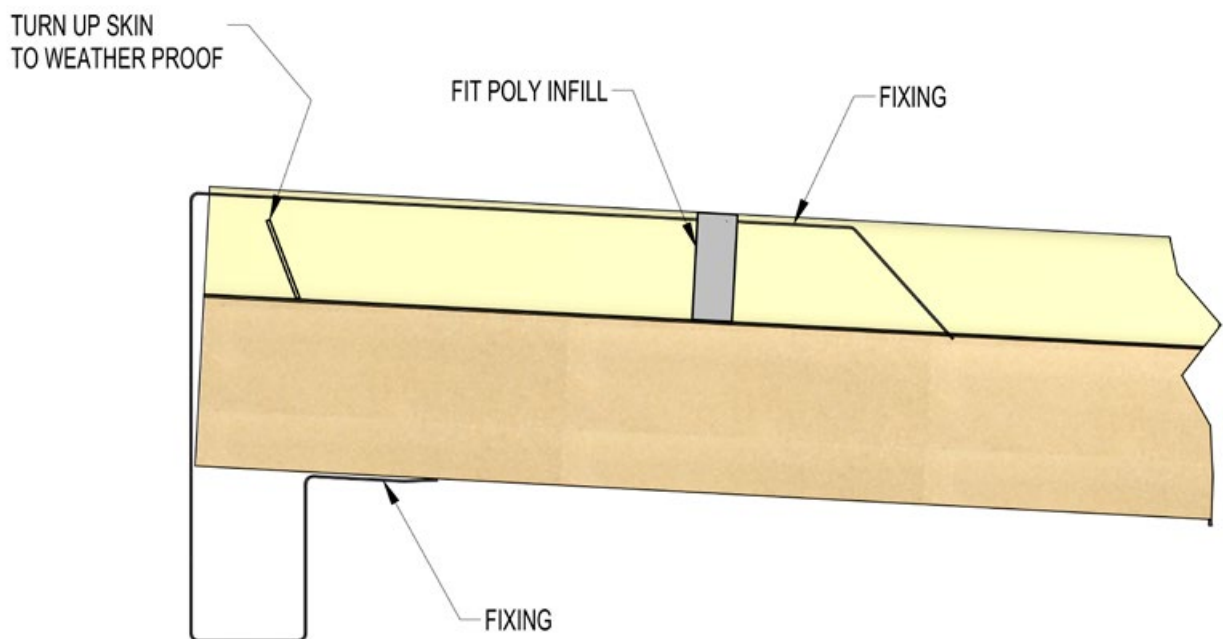
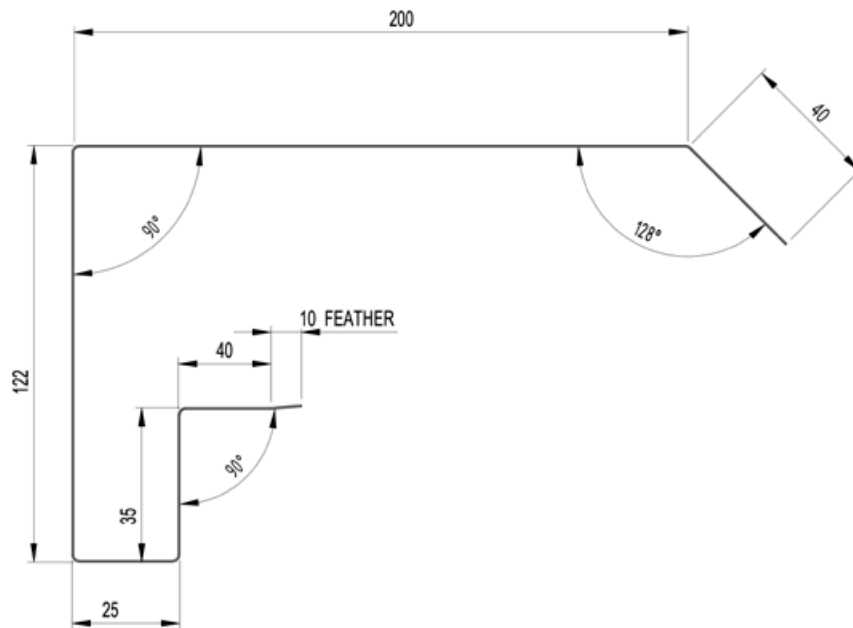

Rear Barge Capping Assembly Detail

Flashing must be fitted in accordance with the relevant standard.

15. INSTALLATION - FLASHINGS

DeltaTrim™

DeltaTrim Fascia Flashing

MATERIAL: 0.55mm G300

L=NUMBER OF PANELS +100mm

THICKNESS	D
75mm	101
100mm	126
125mm	151
150mm	176
175mm	201
200mm	226

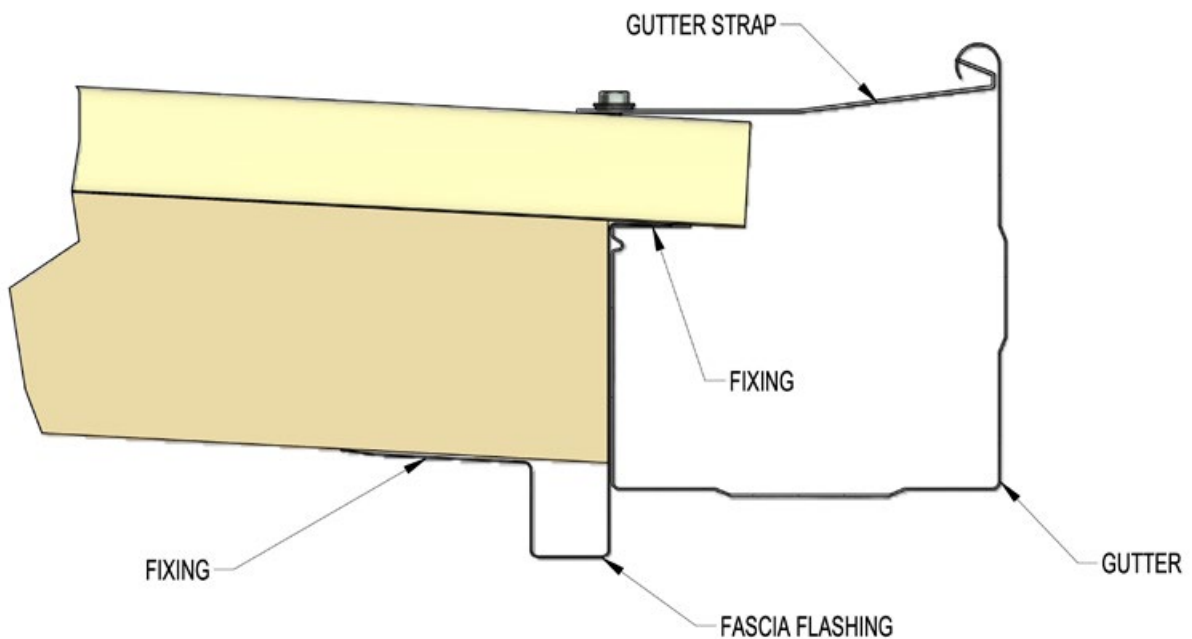
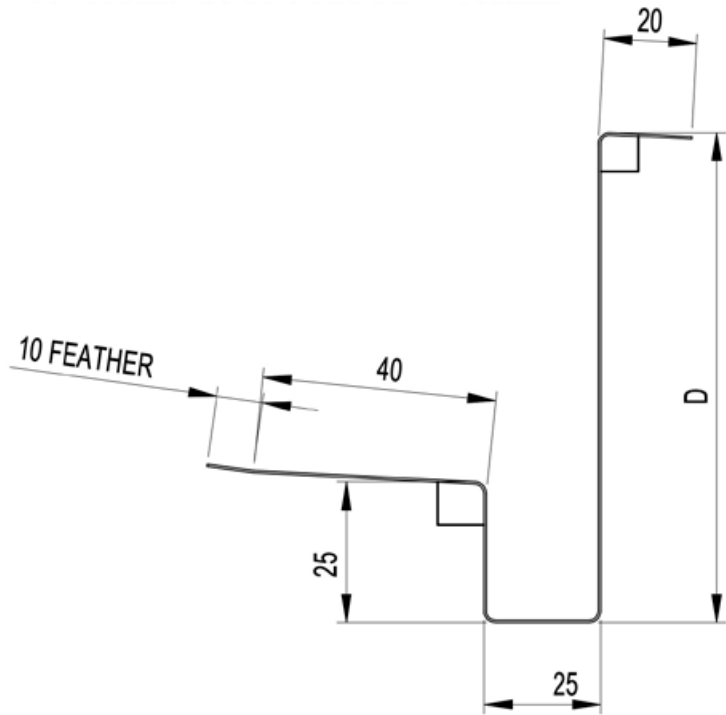

Flashing Assembly Detail

Flashing must be fitted in accordance with the relevant standard.

15. INSTALLATION - FLASHINGS

DeltaTrim™

DeltaTrim Fascia Flashing - 50mm Only

MATERIAL: 0.55mm G300

L=NUMBER OF PANELS +100mm

ROOF PITCH FOR THIS ORDER		
ANGLE	STD	REQD
A	2°°

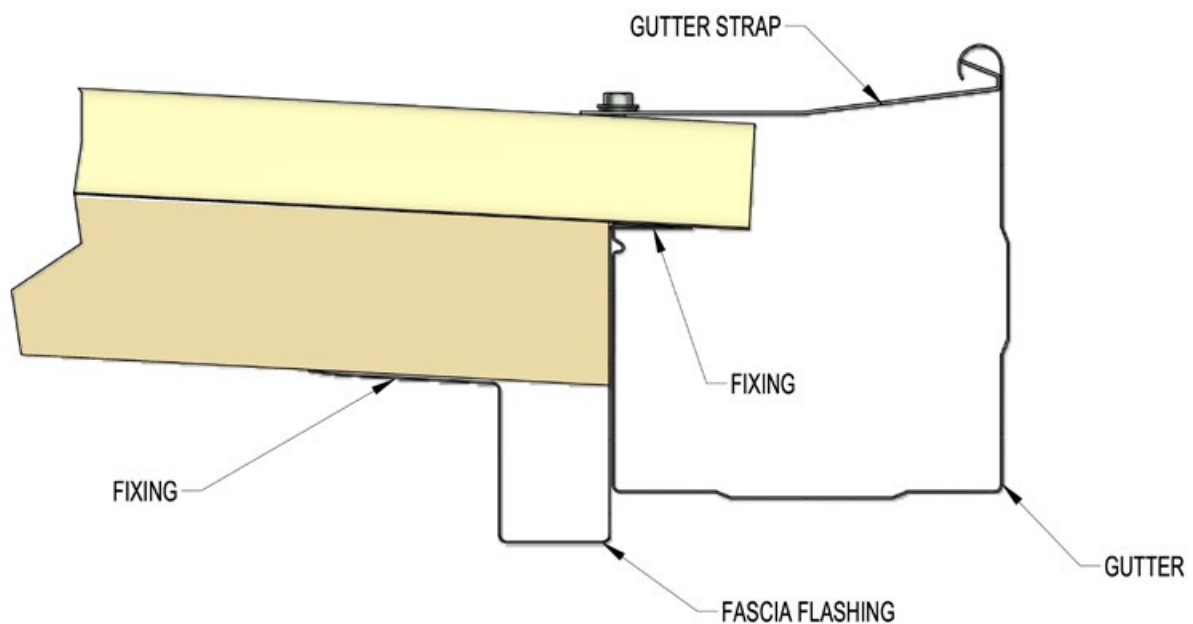
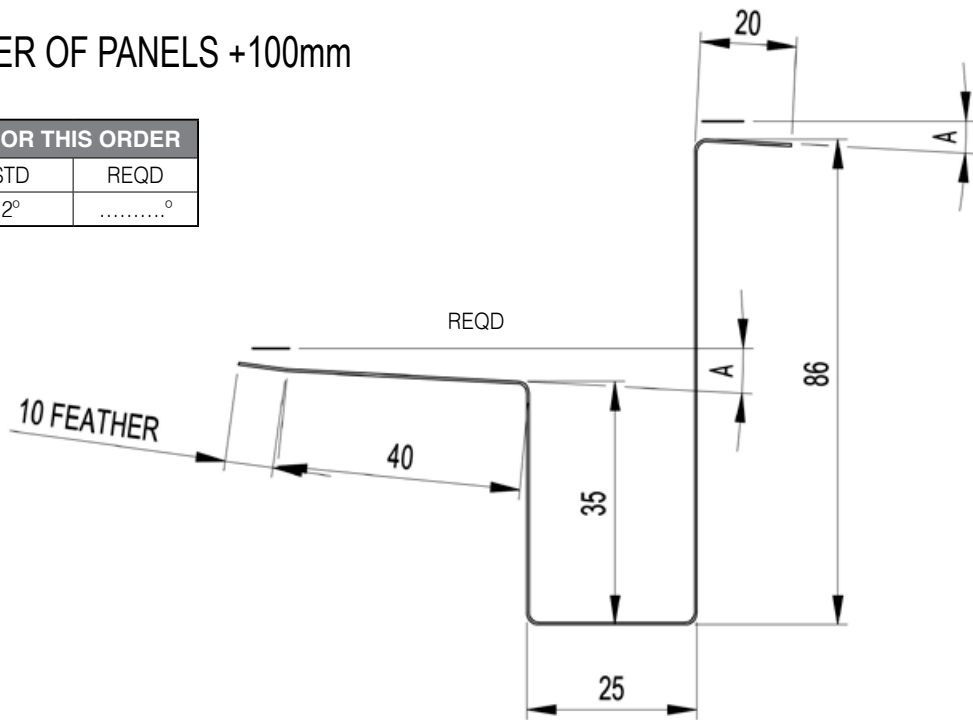

Flashing Assembly Detail

Flashing must be fitted in accordance with the relevant standard.

15. INSTALLATION - FLASHINGS



DeltaOrb Receiver Channel

MATERIAL: 1.2mm BMT

THICKNESS	D
50mm	72
75mm	97
100mm	122
125mm	147
150mm	172
175mm	197
200mm	222

ROOF PITCH FOR THIS ORDER		
ANGLE	STD	REQD
A	3°°

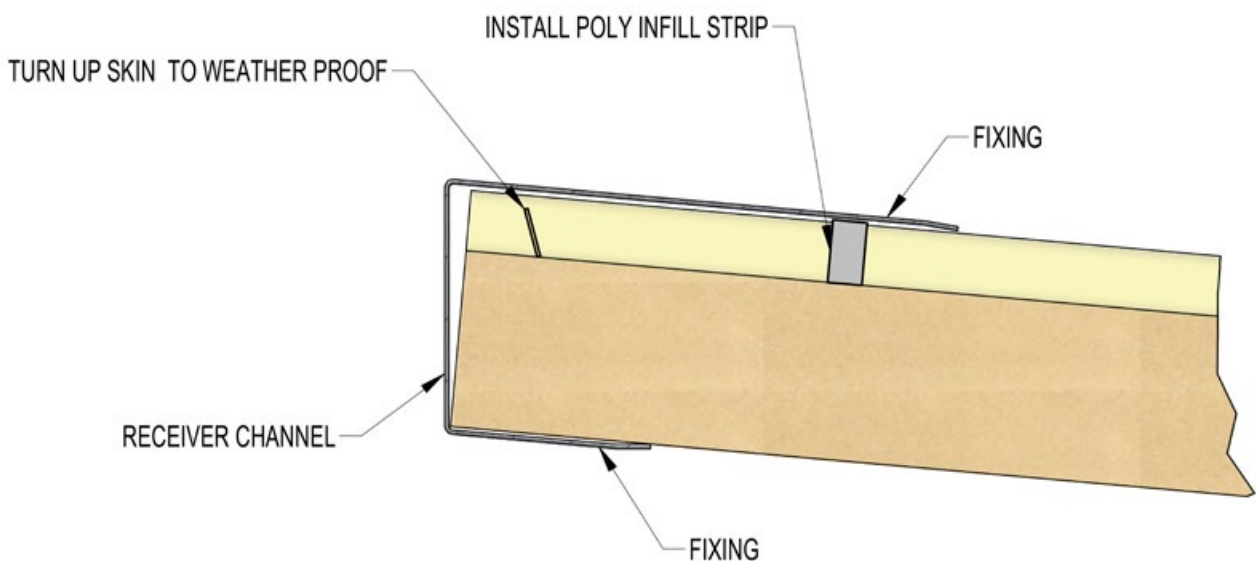
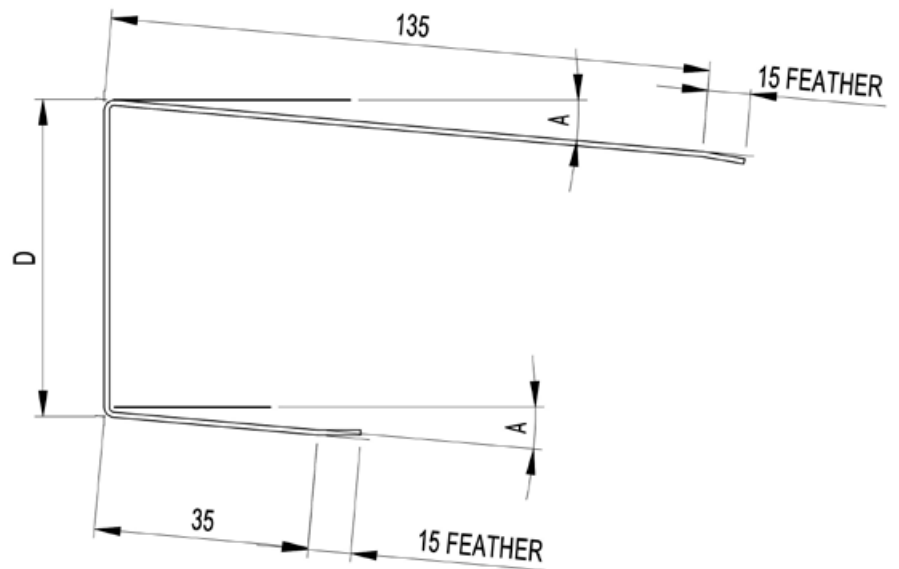

Receiver Channel Assembly Detail

Flashing must be fitted in accordance with the relevant standard.

15. INSTALLATION - FLASHINGS

DeltaOrb™

DeltaOrb Receiver Channel Flashing

MATERIAL: 0.55mm G300

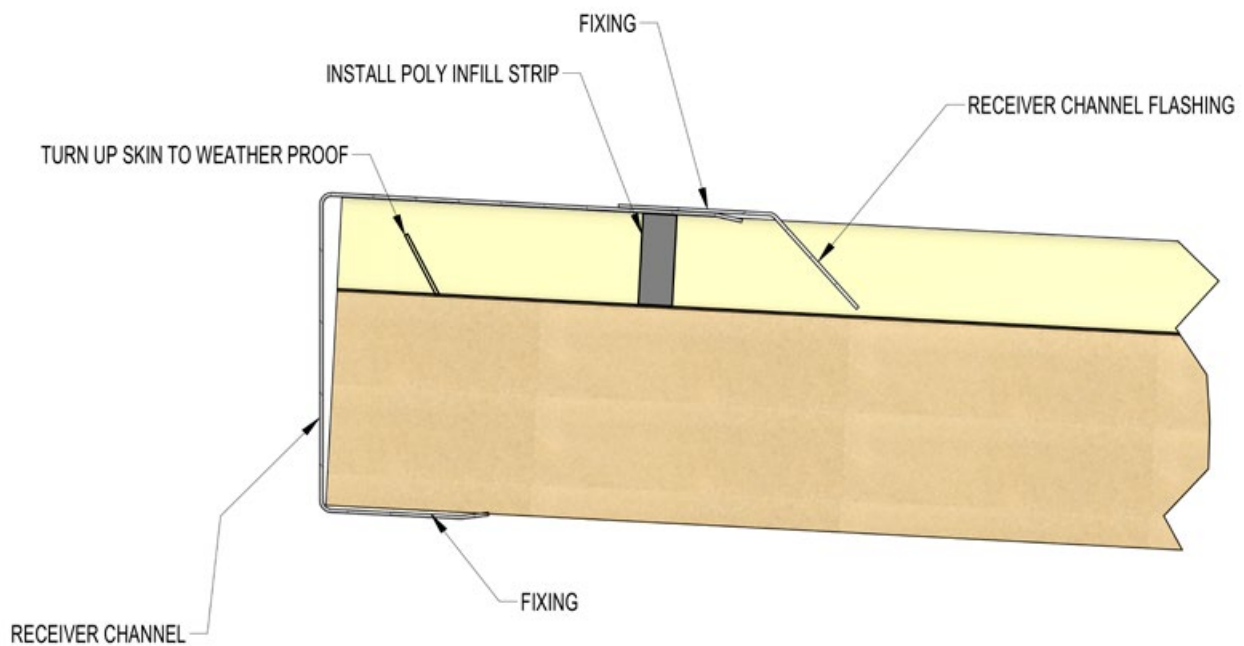
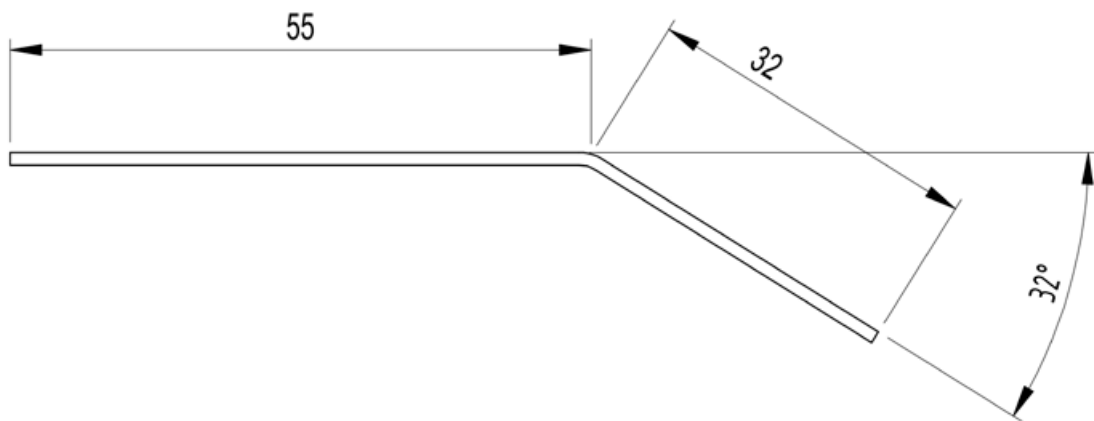

Receiver Channel Flashing Assembly Detail

Flashing must be fitted in accordance with the relevant standard.

15. INSTALLATION - FLASHINGS

DeltaOrb™

DeltaOrb Apron Flashing

MATERIAL: 0.55mm G300

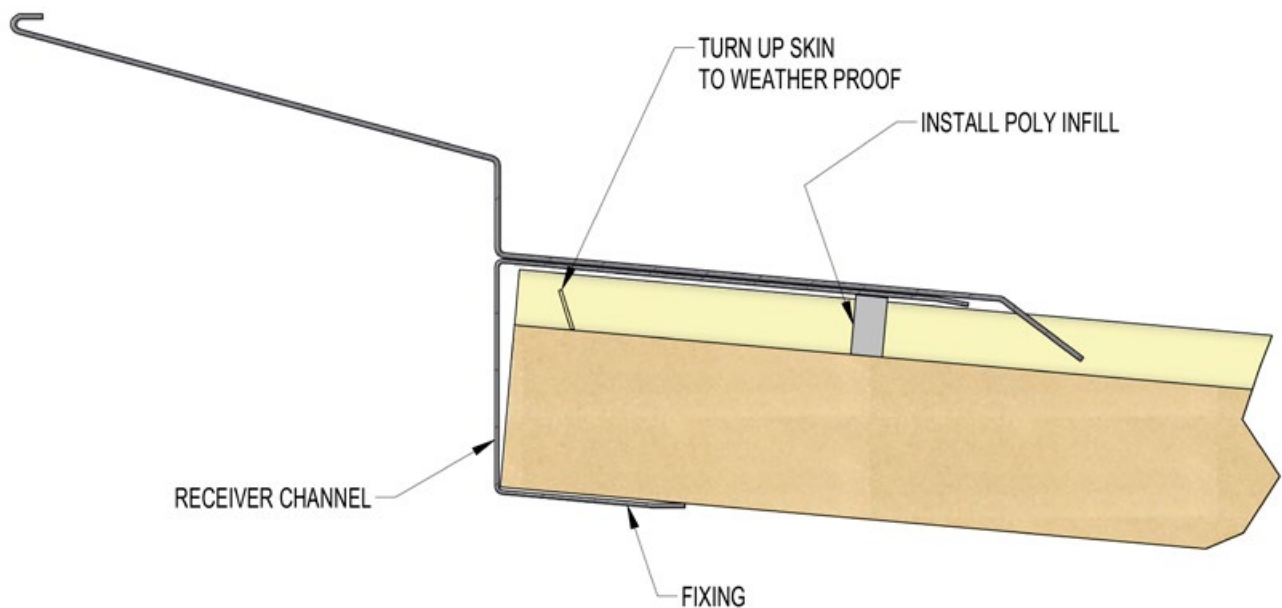
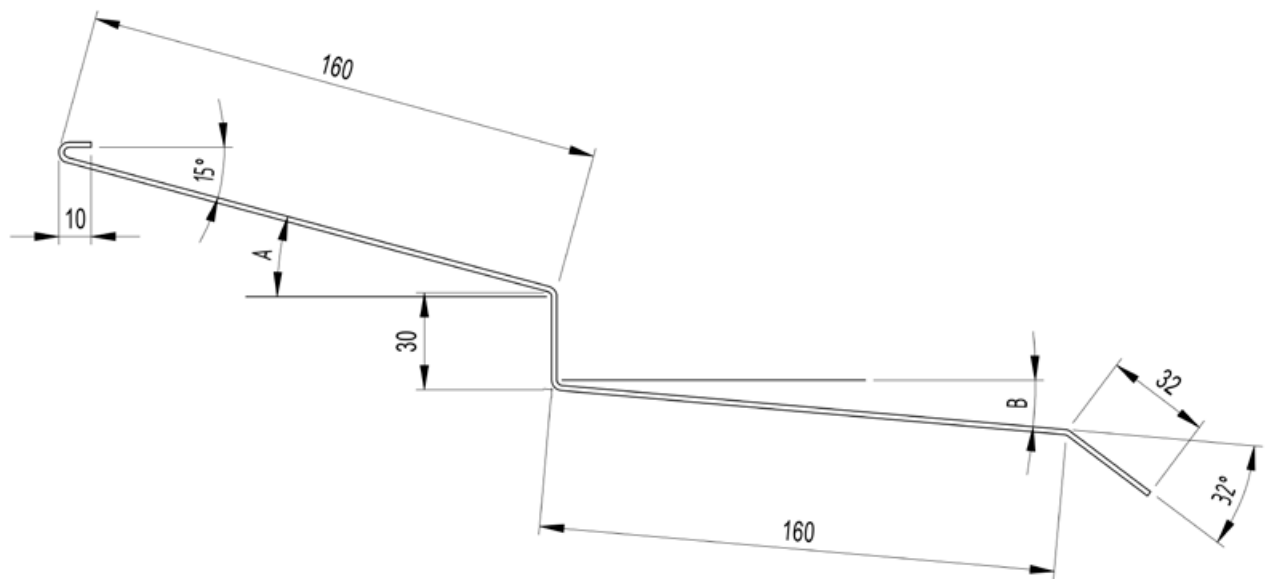

Apron Flashing Assembly Detail

Flashing must be fitted in accordance with the relevant standard.

15. INSTALLATION - FLASHINGS

DeltaOrb™

DeltaOrb Apron Flashing-B

MATERIAL: 0.55mm G300

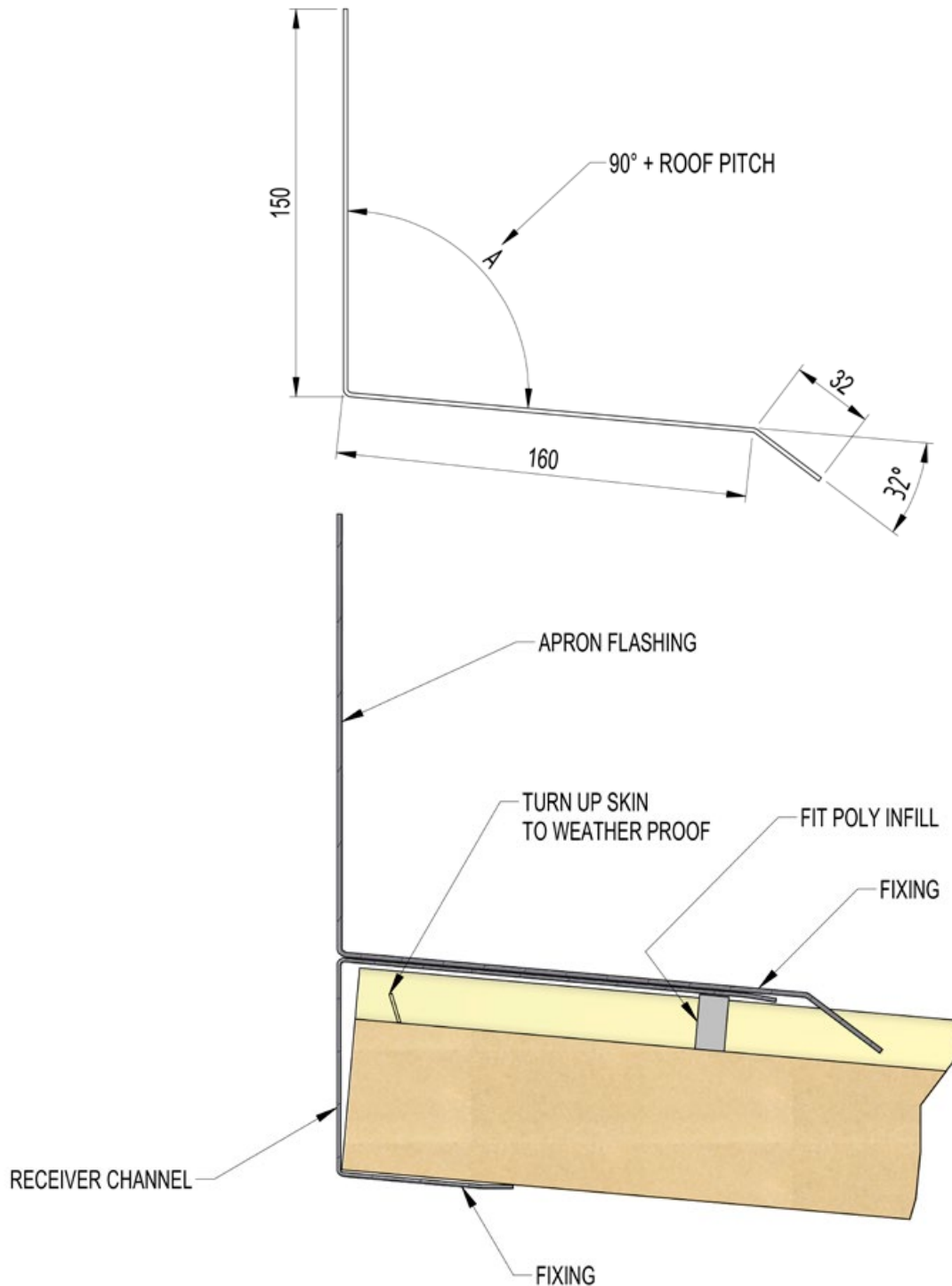

Apron Flashing-B Assembly Detail

Flashing must be fitted in accordance with the relevant standard.

15. INSTALLATION - FLASHINGS

DeltaOrb™

DeltaOrb Ridge Cap

MATERIAL: 0.55mm G300

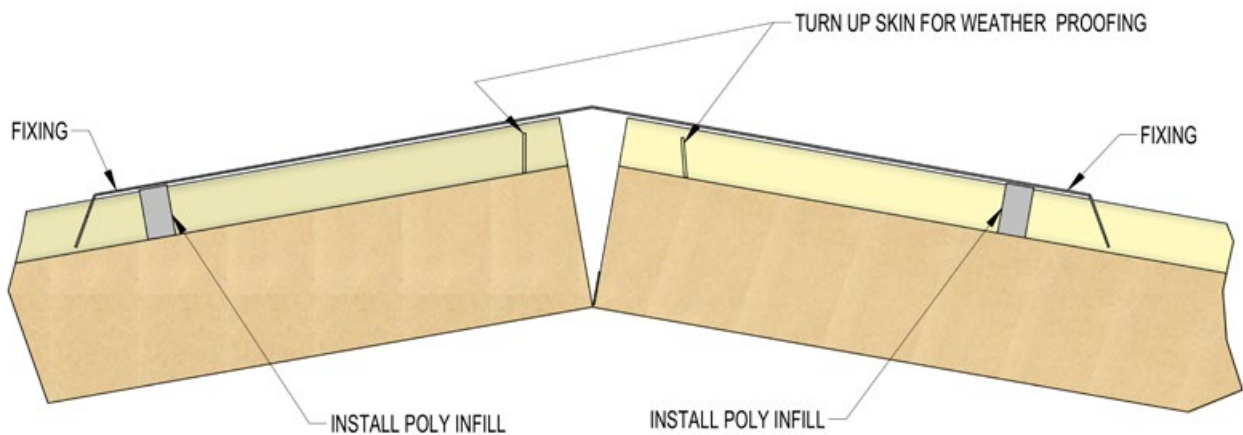
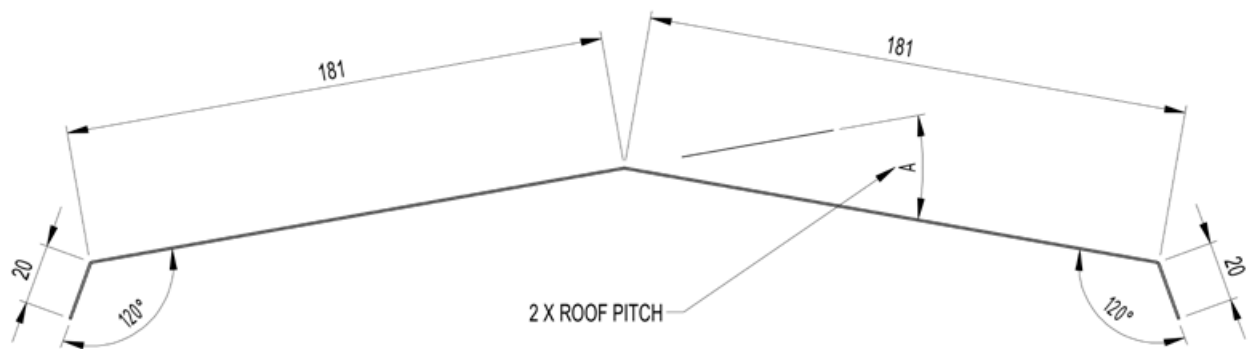

Ridge Cap Fixing Assembly Detail

15. INSTALLATION - FLASHINGS



DeltaOrb Side Barge Capping

MATERIAL: 0.55mm G300

THICKNESS	D
50mm	72
75mm	97
100mm	122
125mm	147
150mm	172
175mm	197
200mm	222

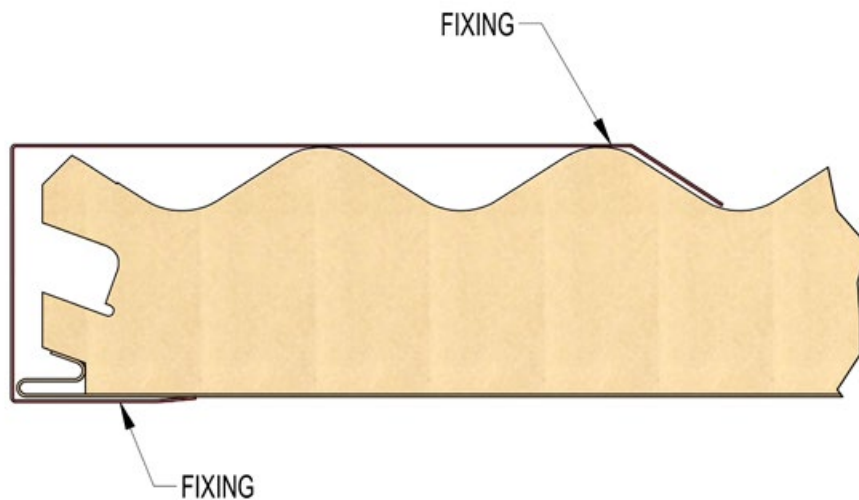
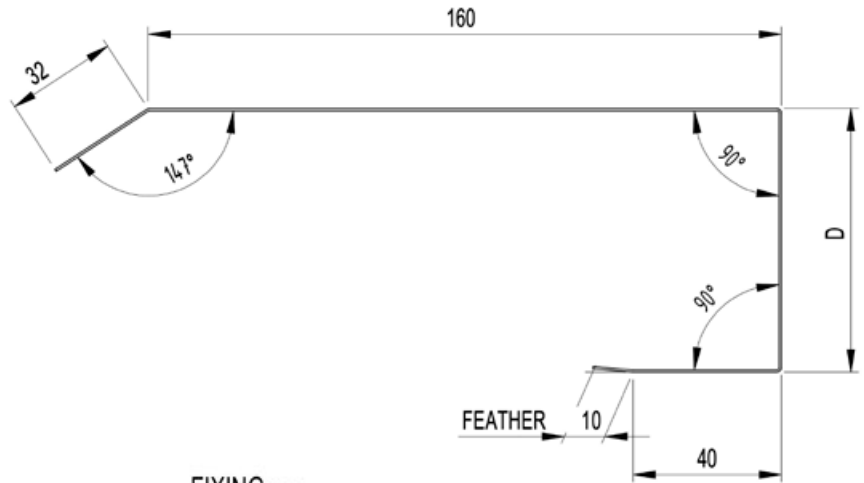

Side Barge Assembly Detail (Female Side)

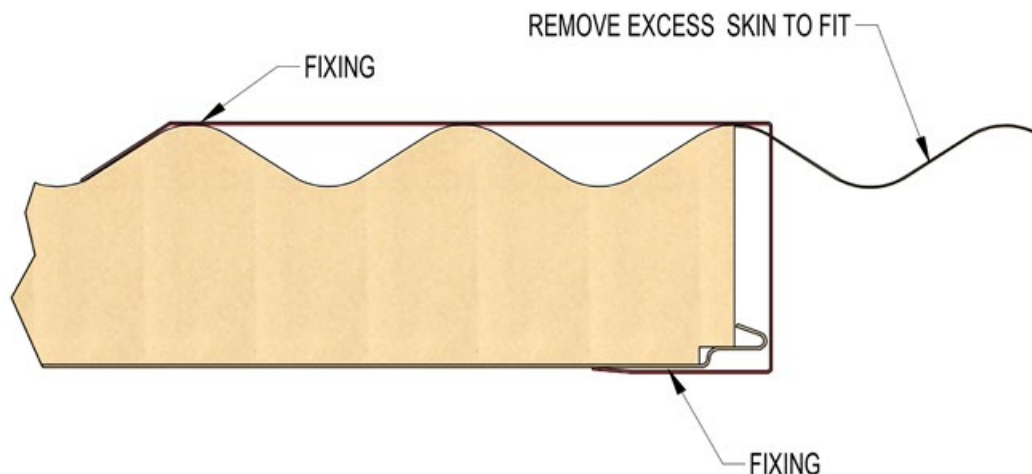

Side Barge Assembly Detail (Male Side)

15. INSTALLATION - FLASHINGS

DeltaOrb™

DeltaOrb Side Barge with Drip Guard

MATERIAL: 0.55mm G300

THICKNESS	D
75mm	122
100mm	147
125mm	172
150mm	197
175mm	222
200mm	247

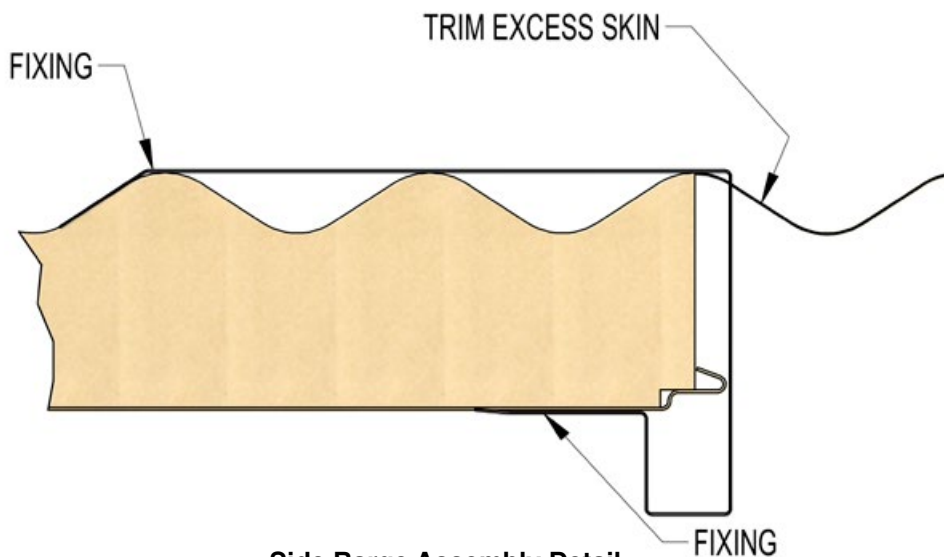
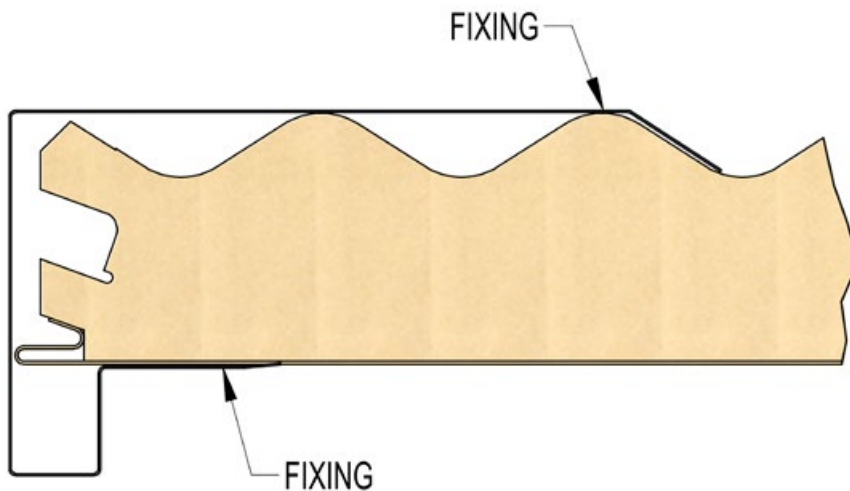
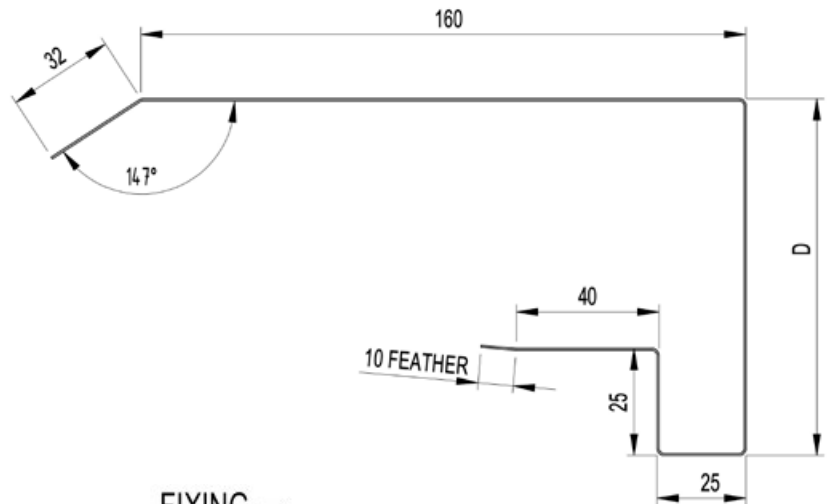

Side Barge Assembly Detail

15. INSTALLATION - FLASHINGS

DeltaOrb™

DeltaOrb Side Barge with Drip Guard - 50mm Only

MATERIAL: 0.55mm G300

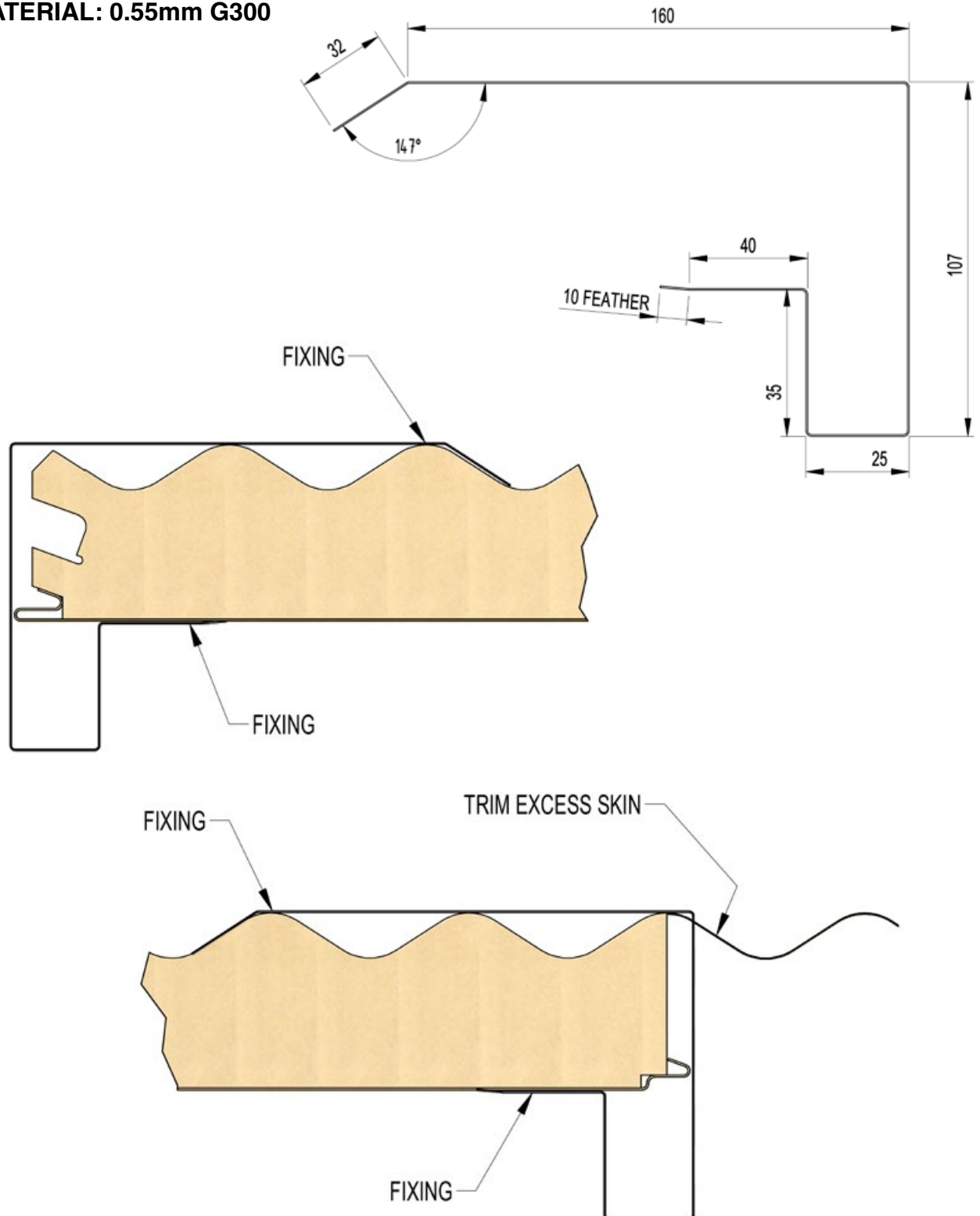

Side Barge Assembly Detail

15. INSTALLATION - FLASHINGS



DeltaOrb Rear Barge Capping

MATERIAL: 0.55mm G300

THICKNESS	D
50mm	72
75mm	97
100mm	122
125mm	147
150mm	172
175mm	197
200mm	222

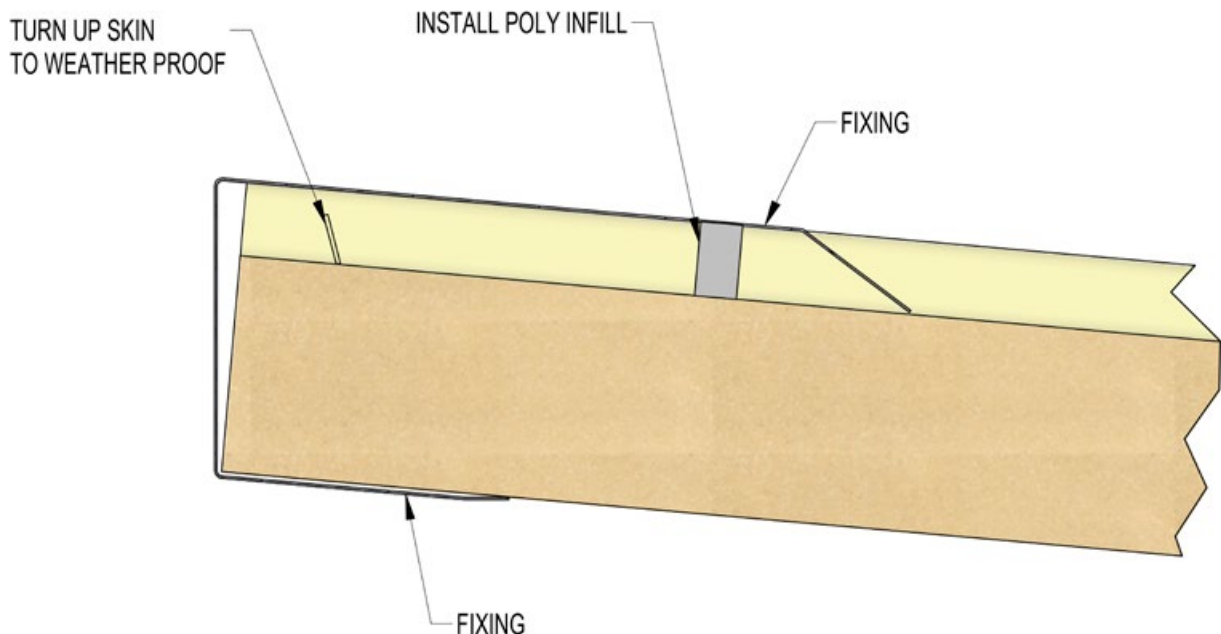
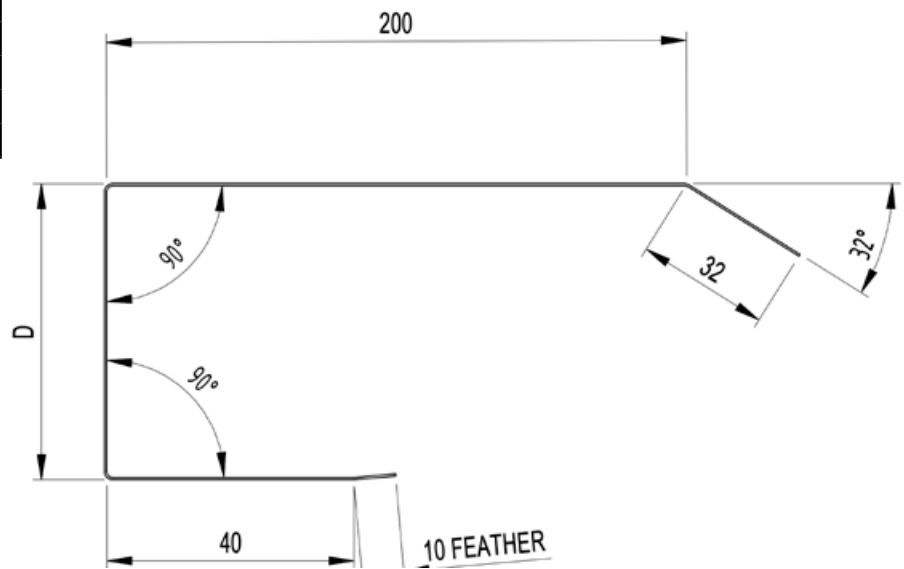

Rear Barge Capping Assembly Detail

15. INSTALLATION - FLASHINGS

DeltaOrb™

DeltaOrb Rear Barge Capping with Drip Guard

MATERIAL: 0.55mm G300

THICKNESS	D
75mm	122
100mm	147
125mm	172
150mm	197
175mm	222
200mm	247

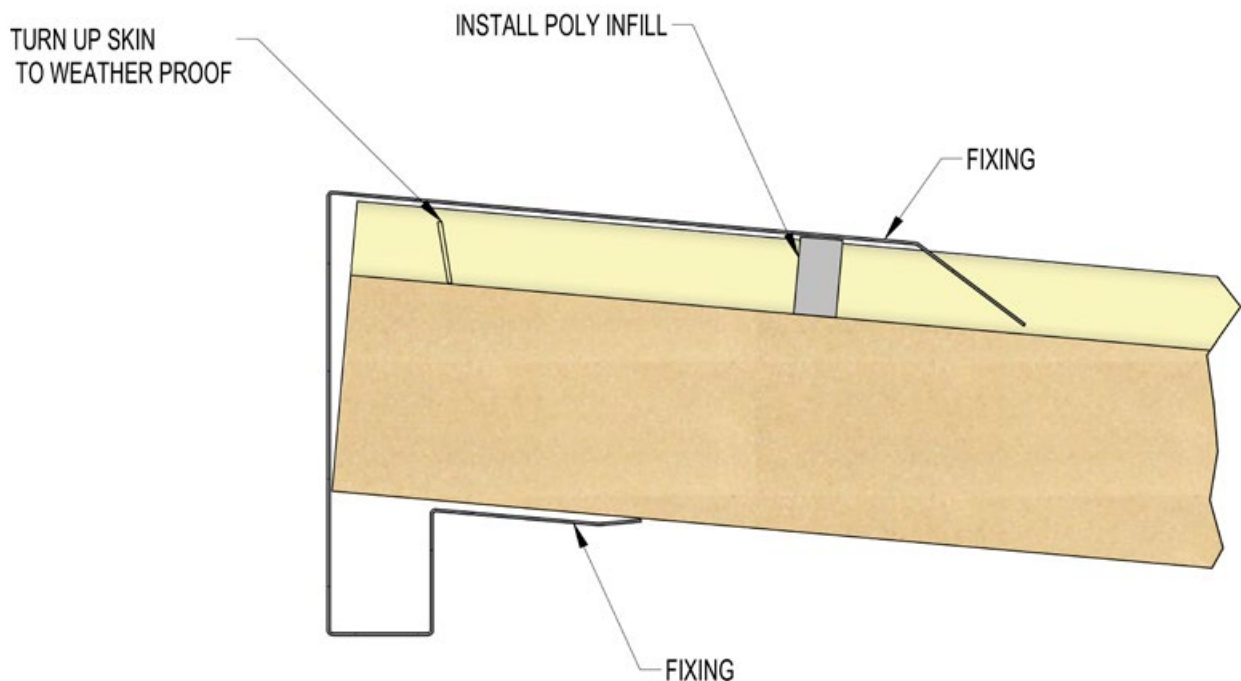
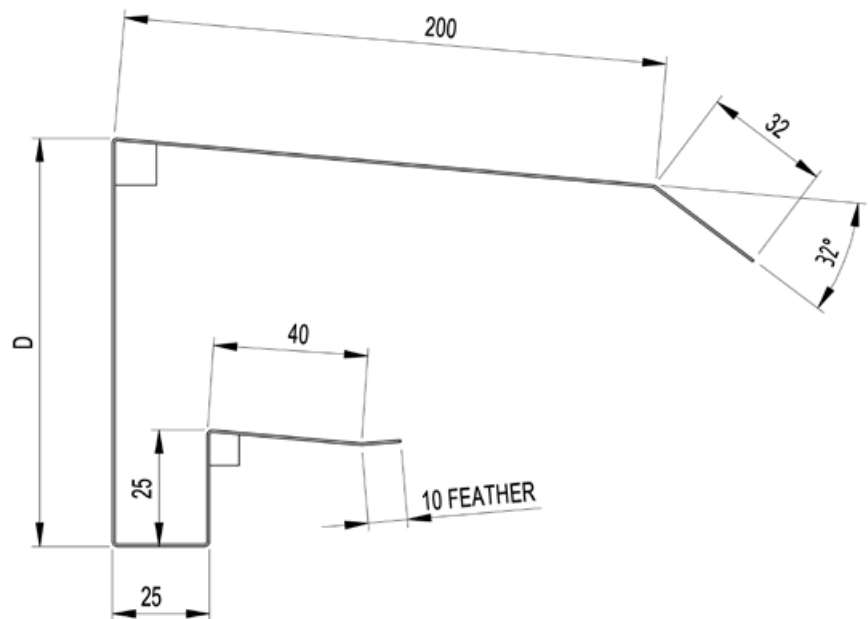

Rear Barge Capping Assembly Detail

15. INSTALLATION - FLASHINGS

DeltaOrb™

DeltaOrb Rear Barge Capping with Drip Guard - 50mm Only

MATERIAL: 0.55mm G300

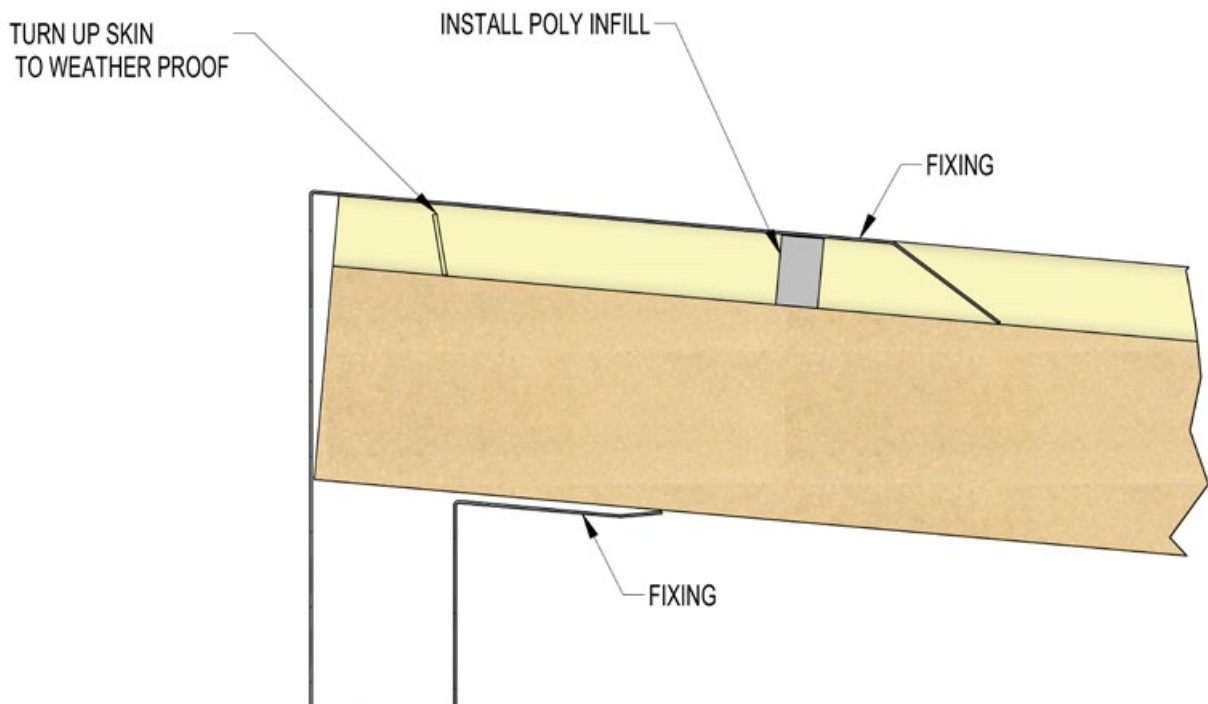
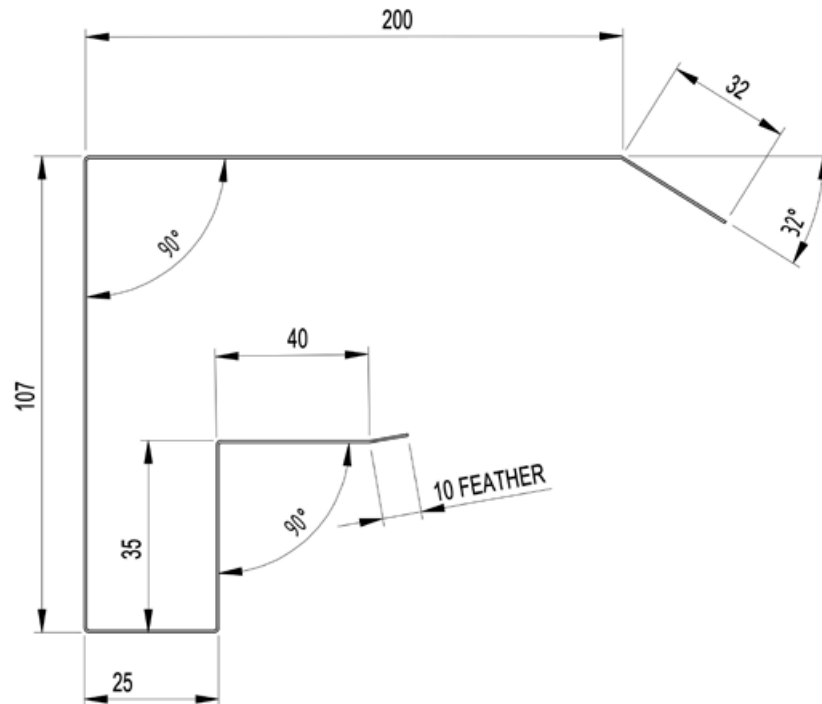

Rear Barge Capping Assembly Detail

15. INSTALLATION - FLASHINGS



DeltaOrb Fascia Flashing

MATERIAL: 0.55mm G300

THICKNESS	D
75mm	101
100mm	126
125mm	151
150mm	176
175mm	201
200mm	226

ROOF PITCH FOR THIS ORDER		
ANGLE	STD	REQD
A	3°°

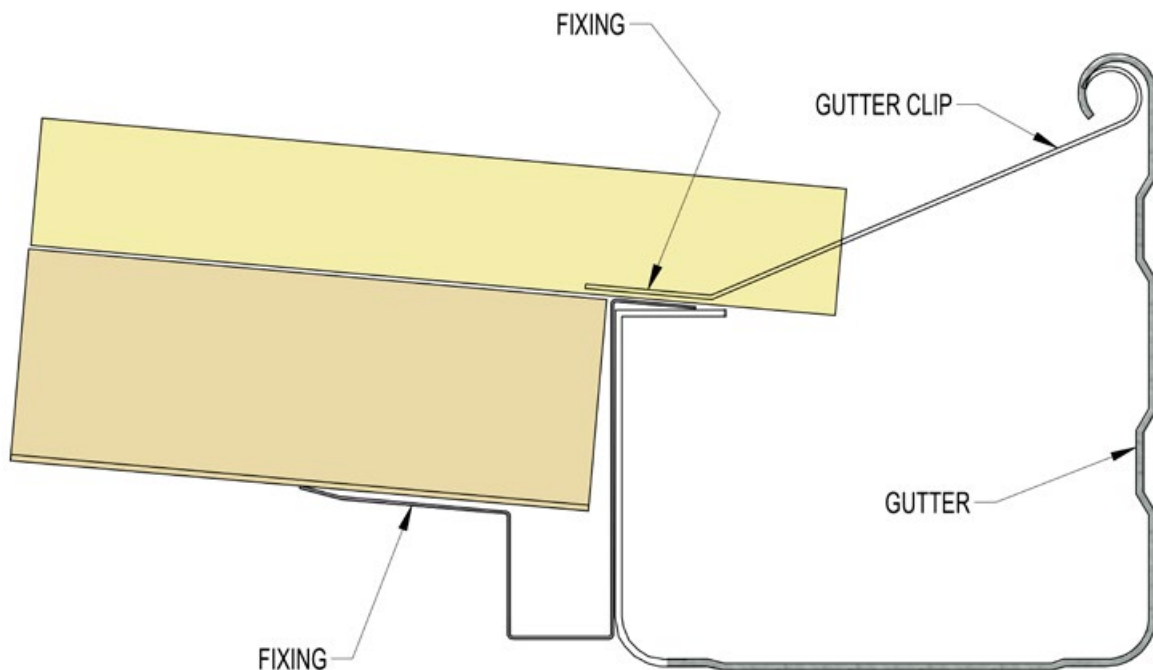
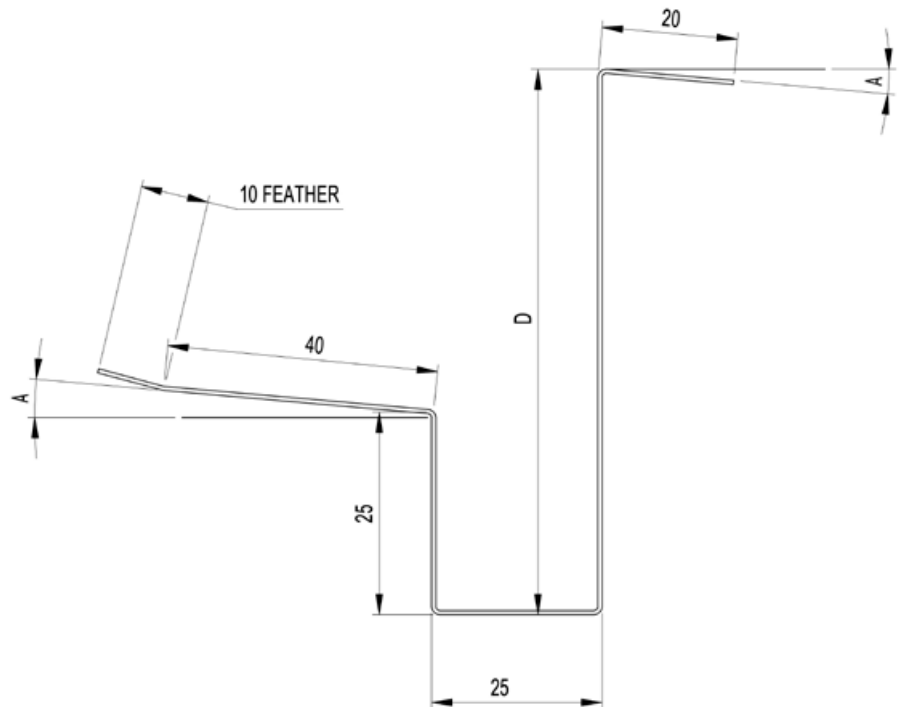

Fascia Flashing Assembly Detail

15. INSTALLATION - FLASHINGS

DeltaOrb™

DeltaOrb Fascia Flashing - 50mm Only

MATERIAL: 0.55mm G300

ROOF PITCH FOR THIS ORDER		
ANGLE	STD	REQD
A	3°°

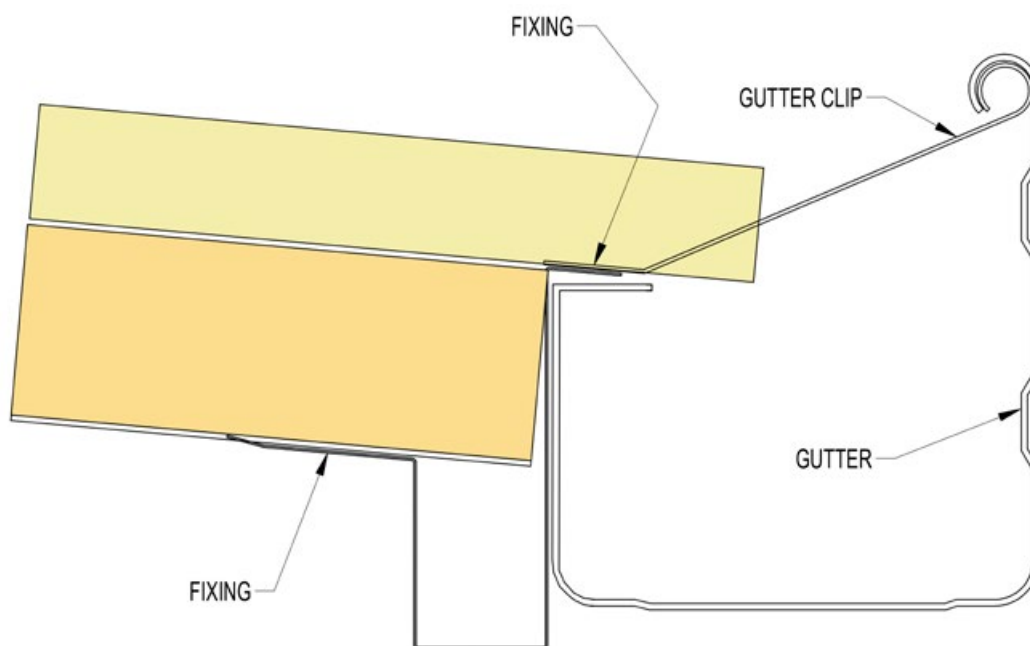
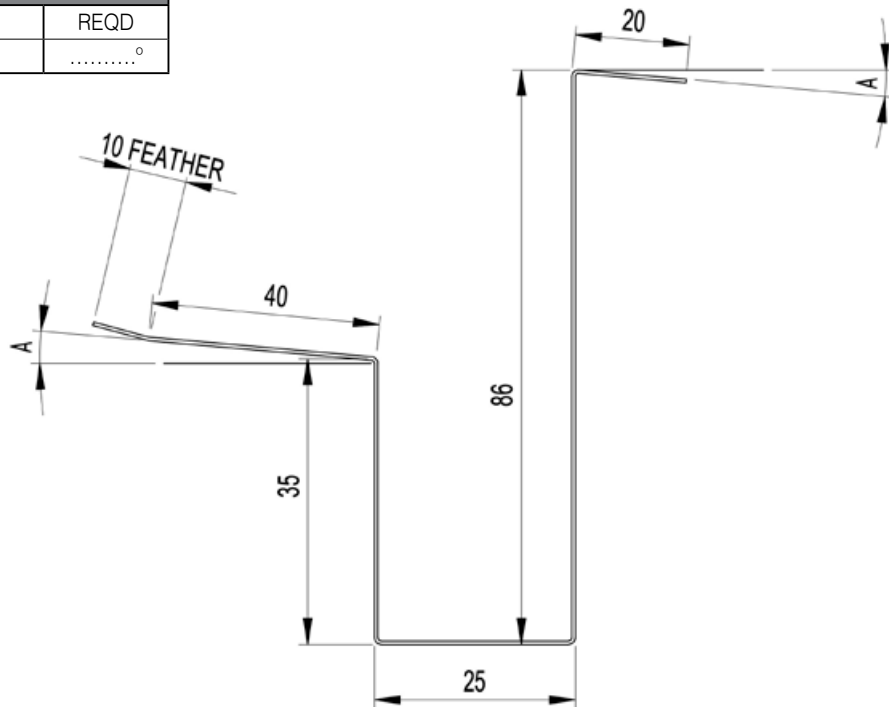

Fascia Flashing Assembly Detail

15. INSTALLATION - FLASHINGS



DeltaOrb Fascia “BAL” Flashing

MATERIAL: 0.55mm G300

THICKNESS	D
50mm	80
75mm	105
100mm	130
125mm	155
150mm	180
175mm	205
200mm	230

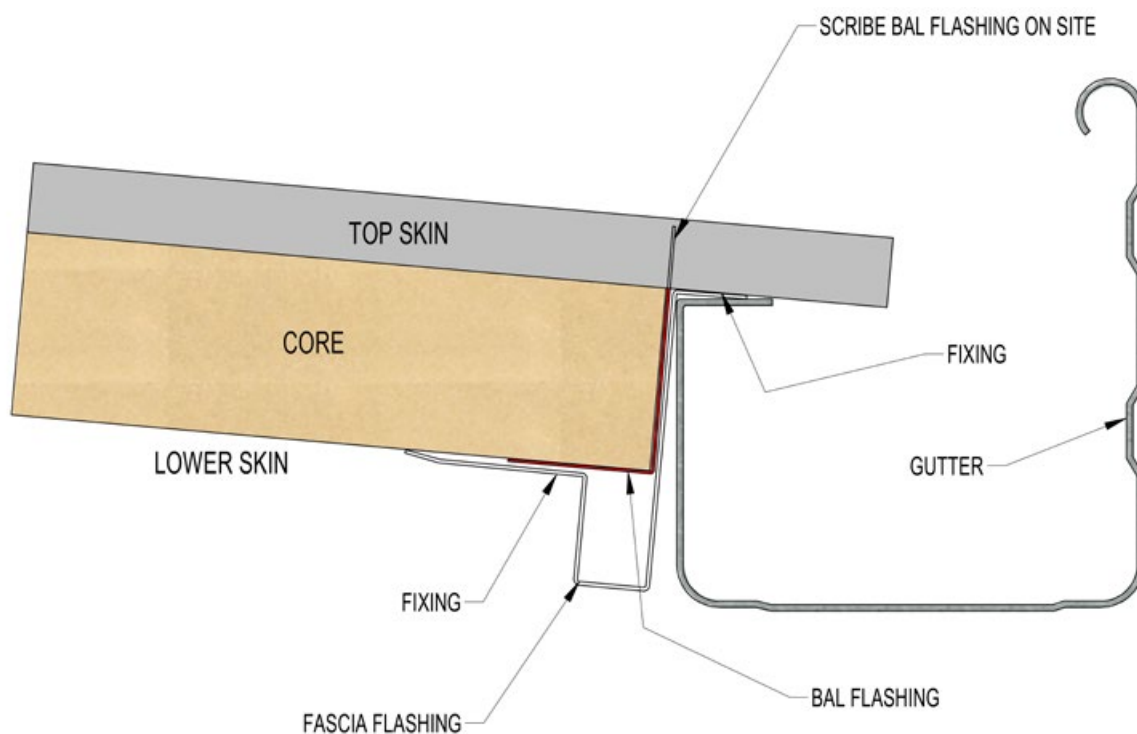
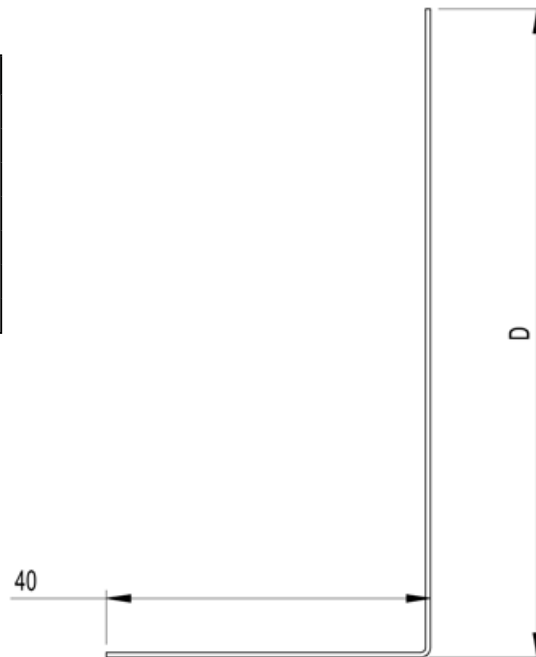

Fascia Flashing Assembly Detail

15. INSTALLATION - FLASHINGS

DeltaCorroCorro™

DeltaCorroCorro Receiver Channel

MATERIAL: 1.2mm BMT

THICKNESS	D
75mm	80
100mm	105
125mm	130
150mm	155
175mm	180
200mm	205
225mm	230
250mm	255

ROOF PITCH FOR THIS ORDER		
ANGLE	STD	REQD
A	3°°

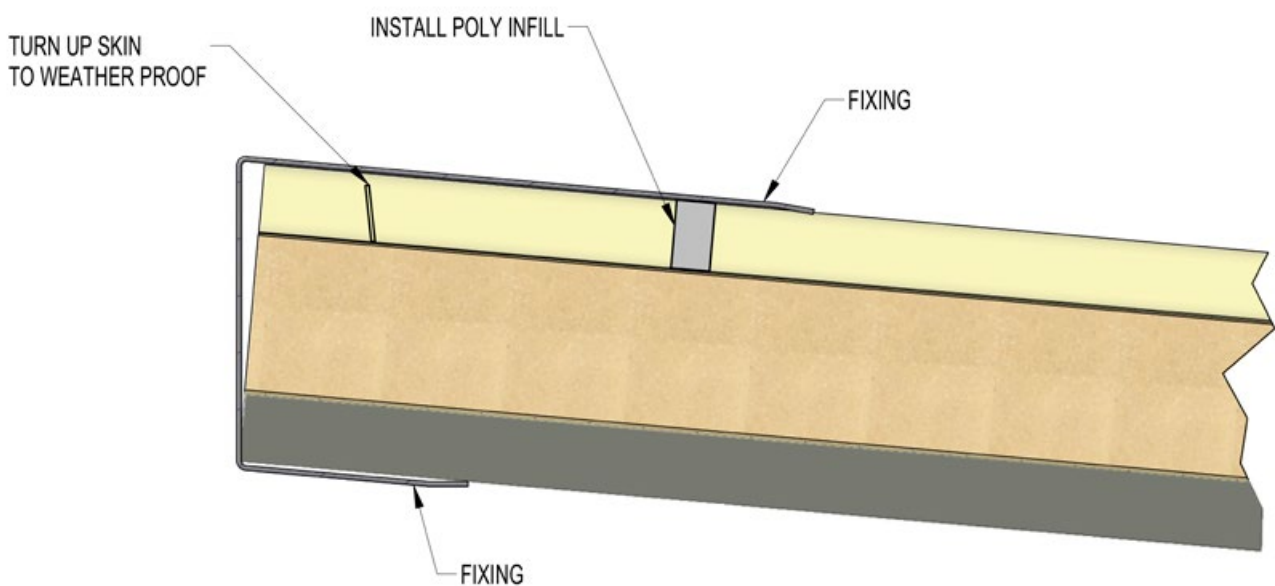
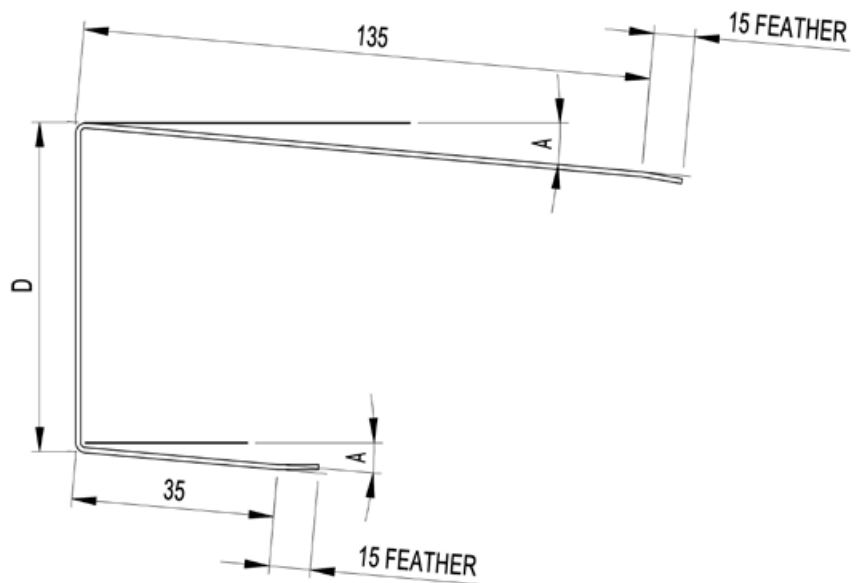

Receiver Channel Assembly Detail

Flashing must be fitted in accordance with the relevant standard.

15. INSTALLATION - FLASHINGS

DeltaCorroCorro™

DeltaCorroCorro Receiver Channel Flashing

MATERIAL: 0.55mm G300

$L = \text{NUMBER OF PANELS} + 50\text{mm}$

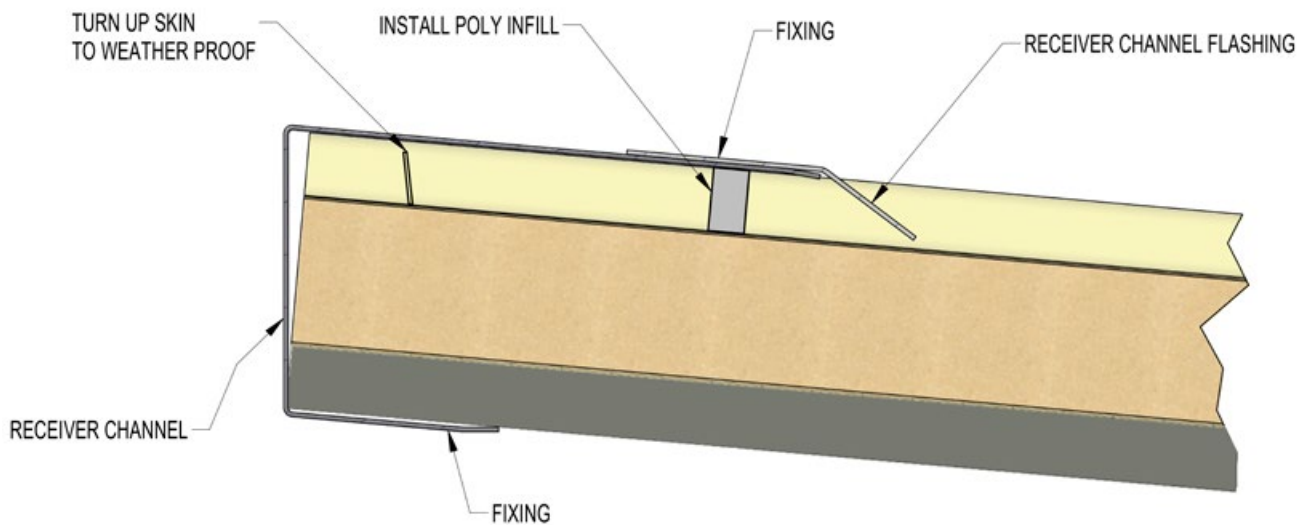
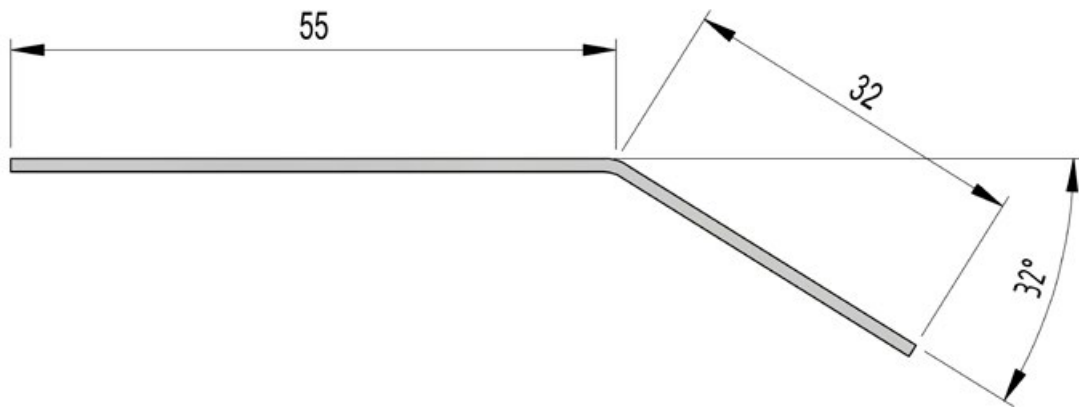

Receiver Channel Flashing Assembly Detail

Flashing must be fitted in accordance with the relevant standard.

15. INSTALLATION - FLASHINGS

DeltaCorroCorro™

DeltaCorroCorro Apron Flashing

MATERIAL: 0.55mm G300

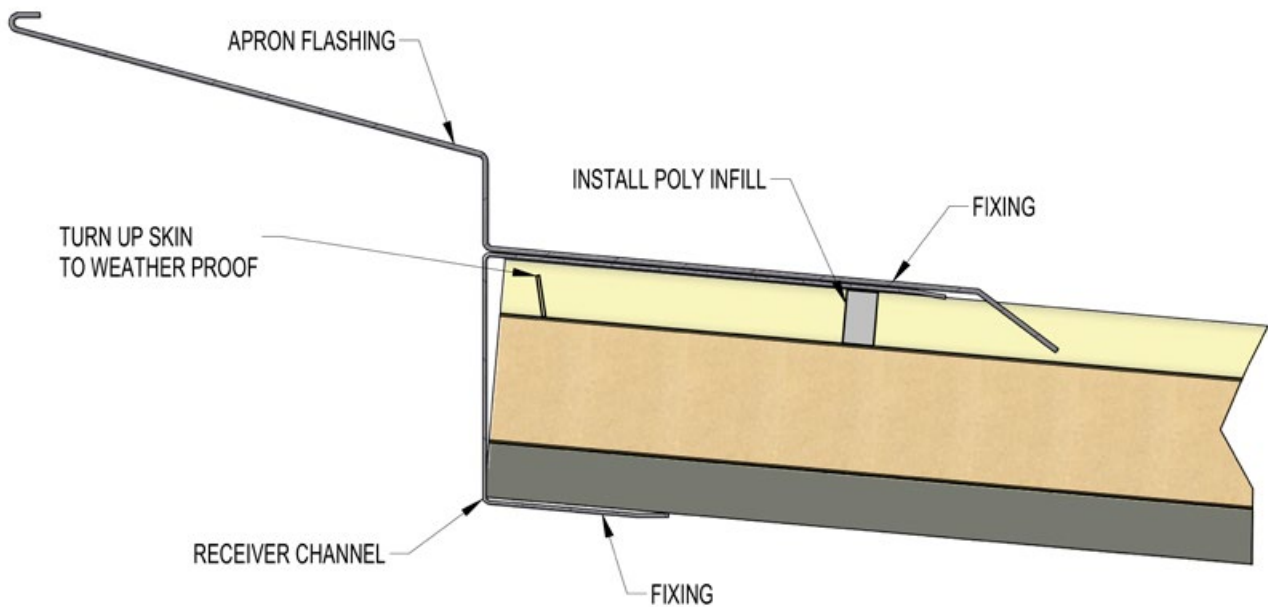
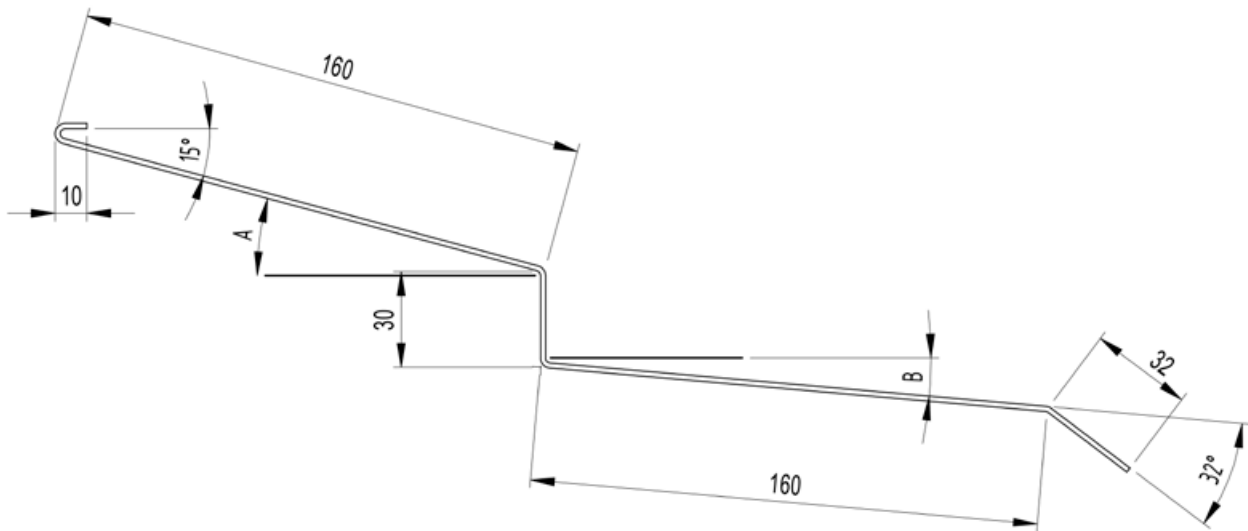

Apron Flashing Assembly Detail

Flashing must be fitted in accordance with the relevant standard.

15. INSTALLATION - FLASHINGS

DeltaCorroCorro™

DeltaCorroCorro Apron Flashing - B

MATERIAL: 0.55mm G300

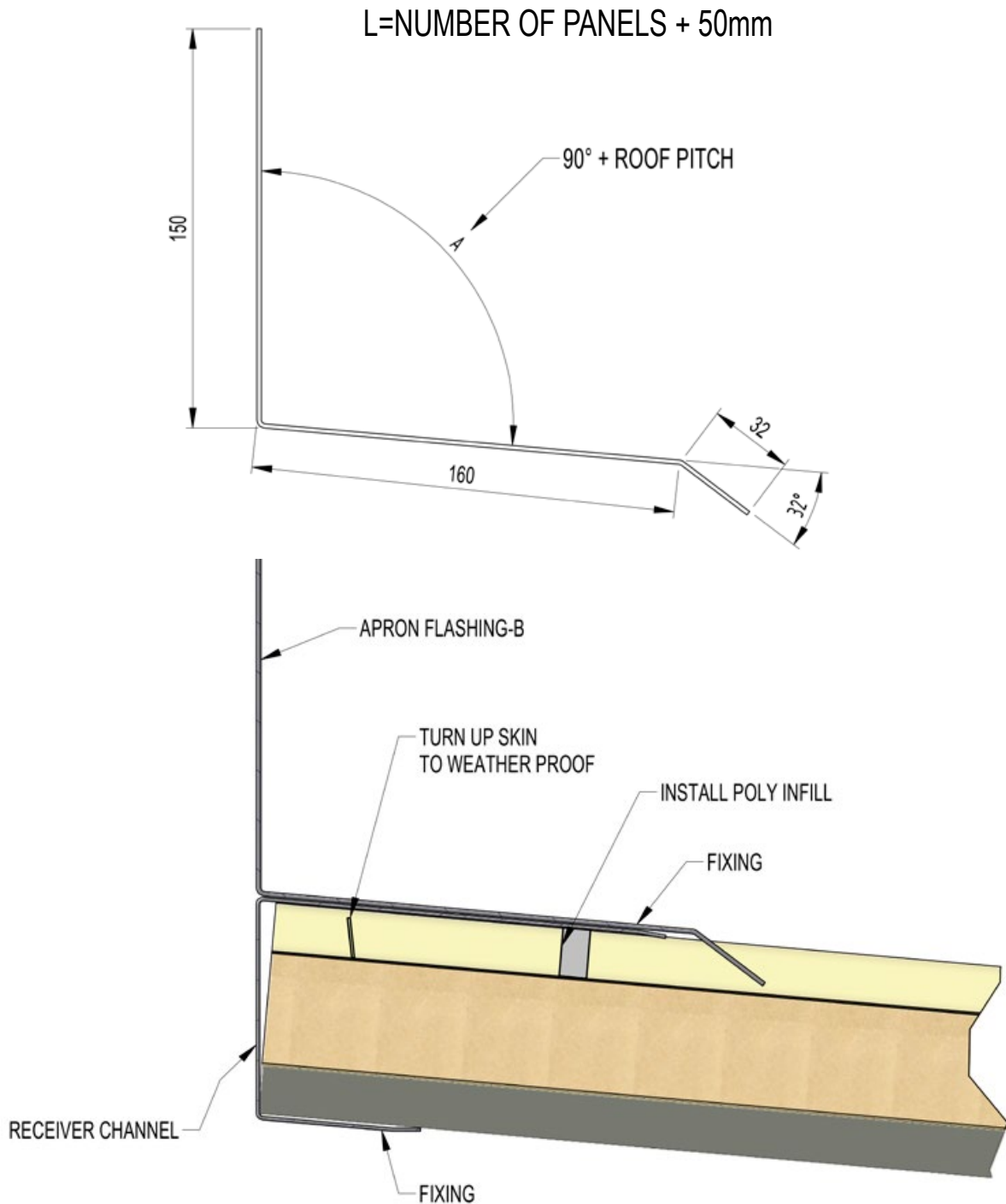

Apron Flashing Assembly Detail

15. INSTALLATION - FLASHINGS

DeltaCorroCorro™

DeltaCorroCorro Ridge Cap

MATERIAL: 0.55mm G300

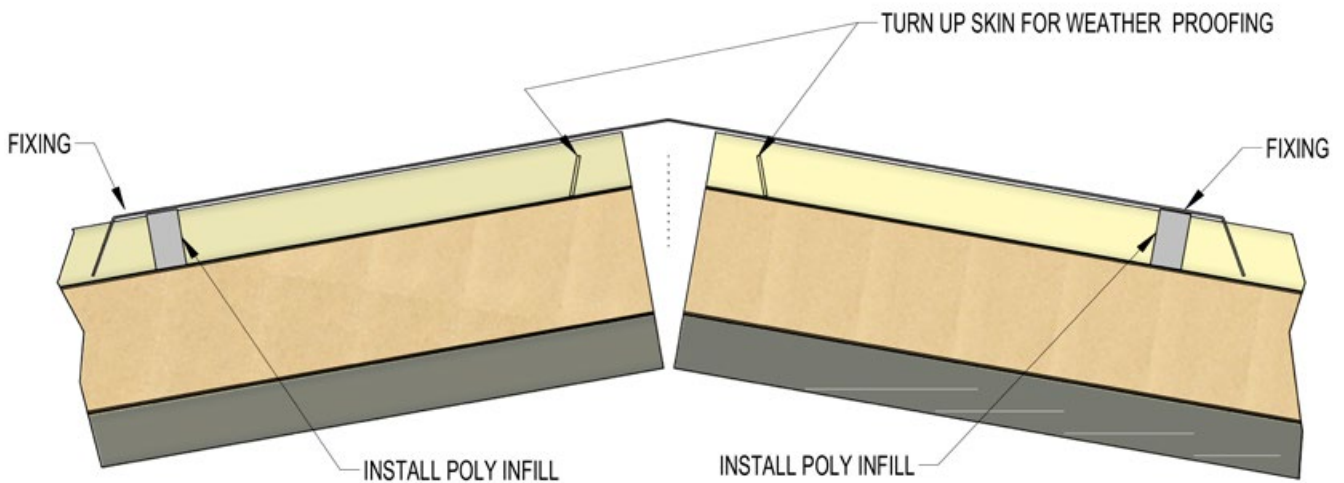
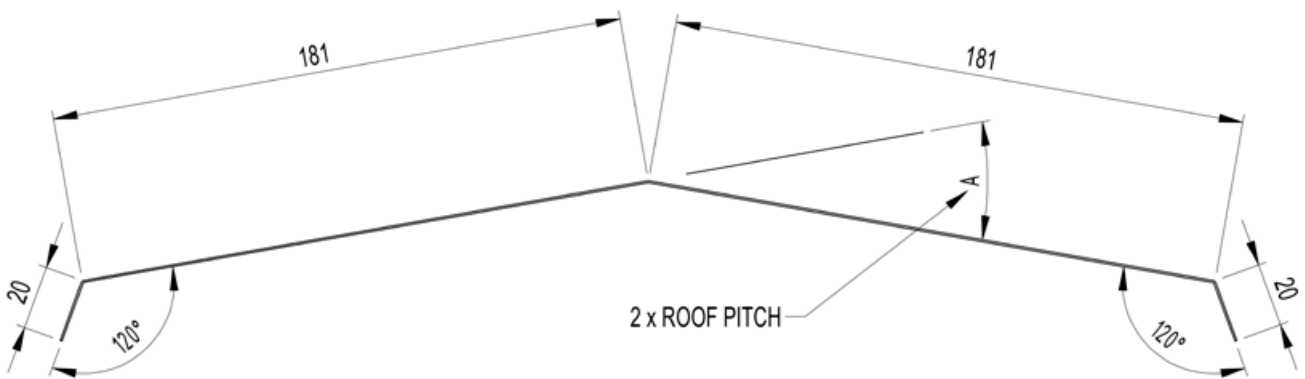

Ridge Cap Fixing Assembly Detail

15. INSTALLATION - FLASHINGS

DeltaCorroCorro™

DeltaCorroCorro Side Barge Capping

MATERIAL: 0.55mm G300

THICKNESS	D
75mm	78
100mm	103
125mm	128
150mm	153
175mm	178
200mm	203
225mm	228
250mm	253

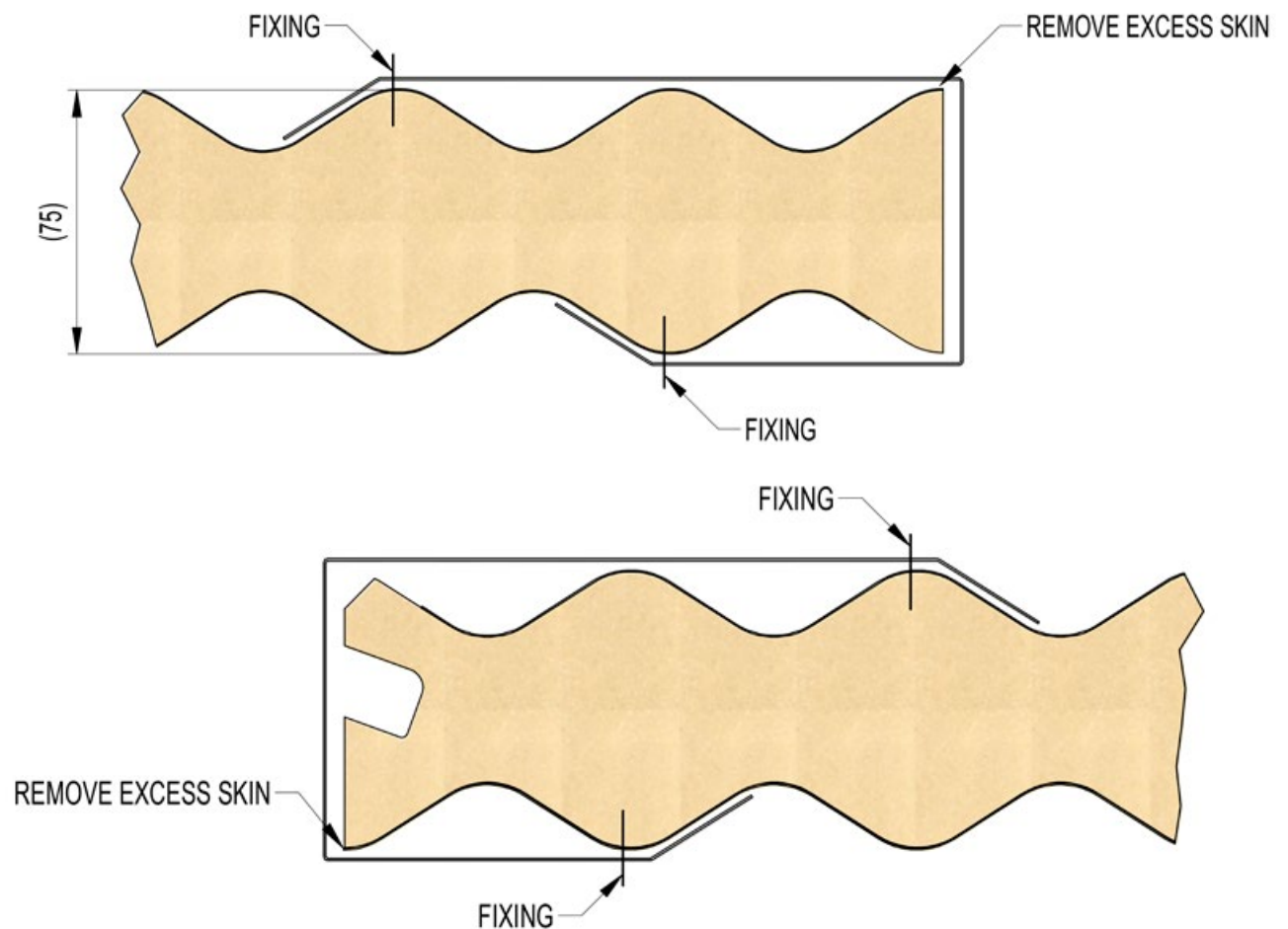
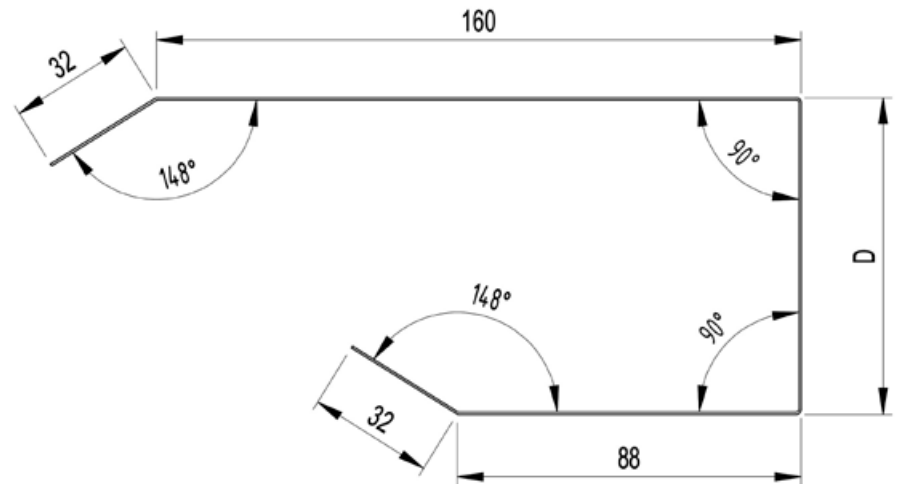

Side Barge Capping Assembly Detail

15. INSTALLATION - FLASHINGS

DeltaCorroCorro™

DeltaCorroCorro Side Barge Capping with Drip Guard

MATERIAL: 0.55mm G300

THICKNESS	D
75mm	103
100mm	128
125mm	153
150mm	178
175mm	203
200mm	228
225mm	253
250mm	278

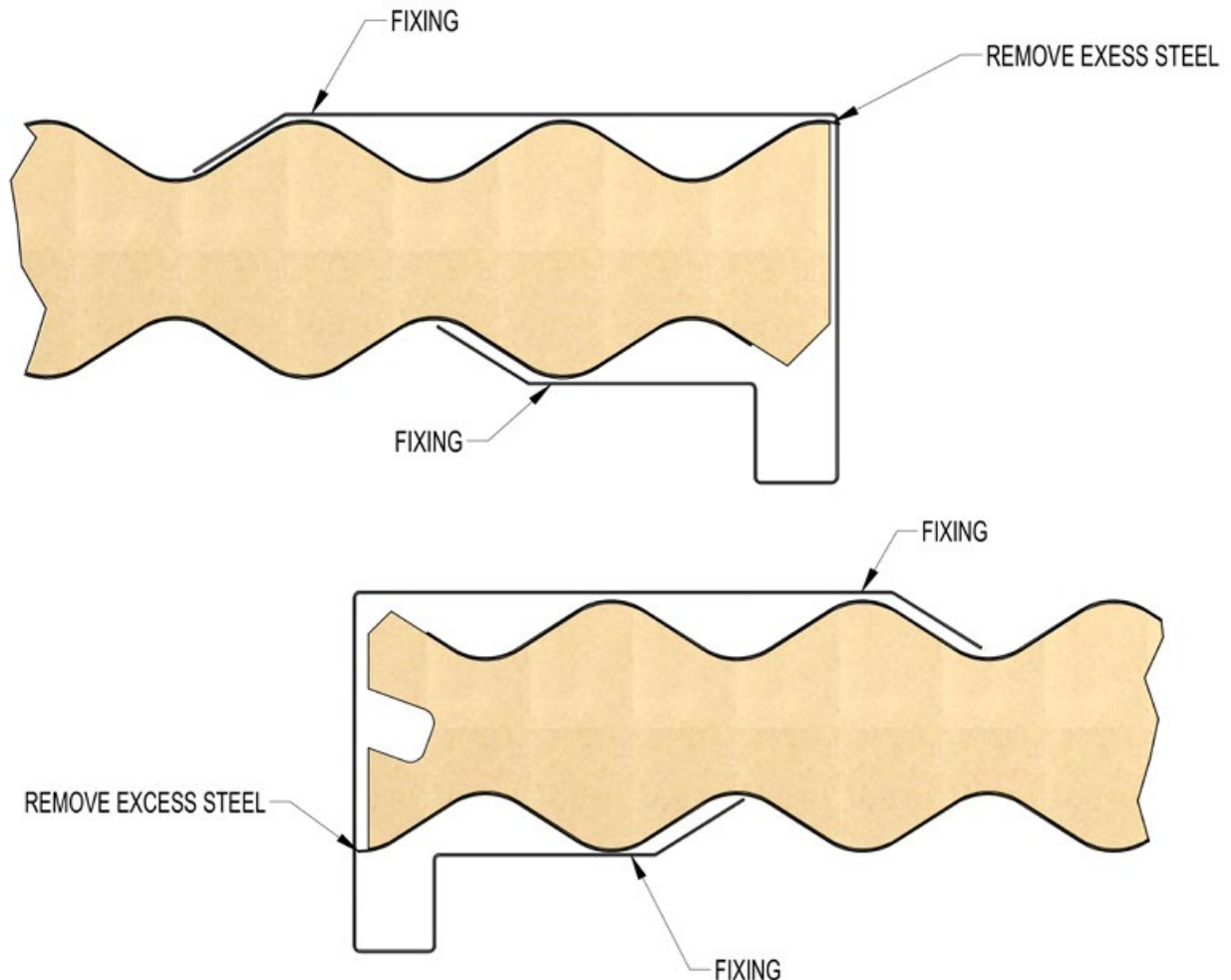
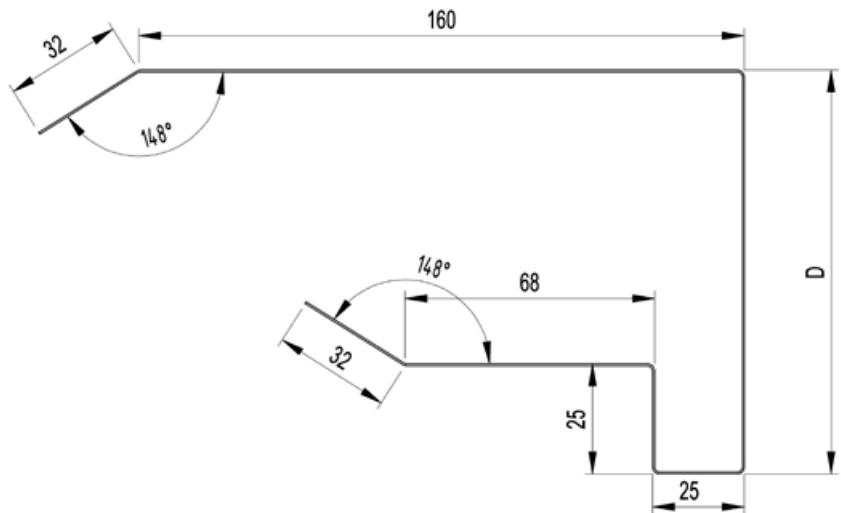

Side Barge Capping with Drip Guard Assembly Detail

15. INSTALLATION - FLASHINGS

DeltaCorroCorro™

DeltaCorroCorro Rear Barge Capping

MATERIAL: 0.55mm G300

THICKNESS	D
75mm	78
100mm	103
125mm	128
150mm	153
175mm	178
200mm	203
225mm	228
250mm	253

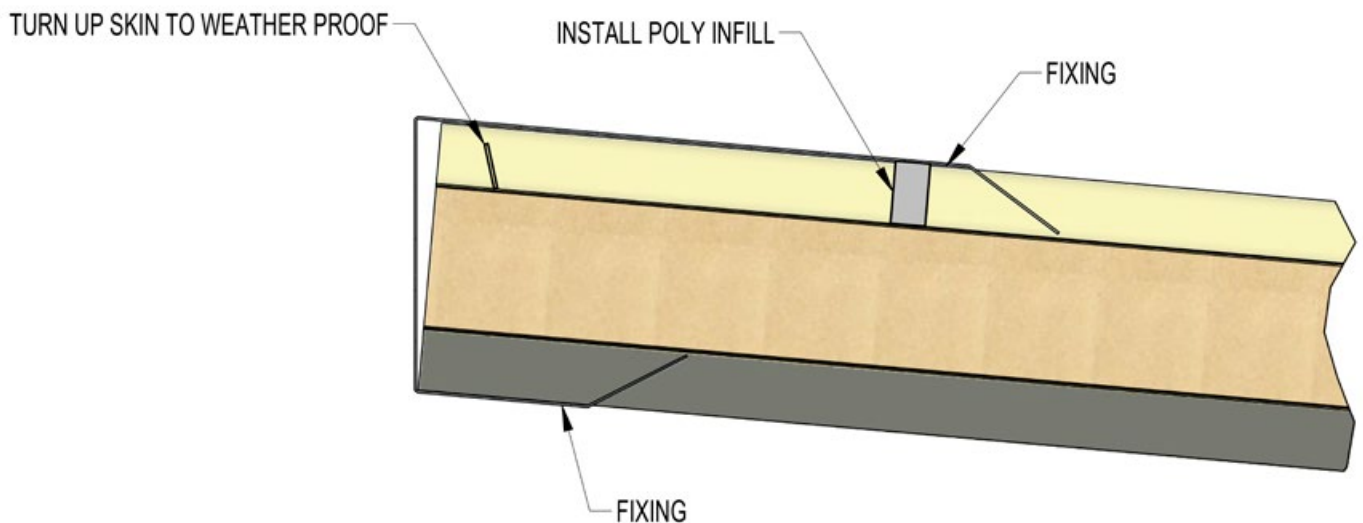
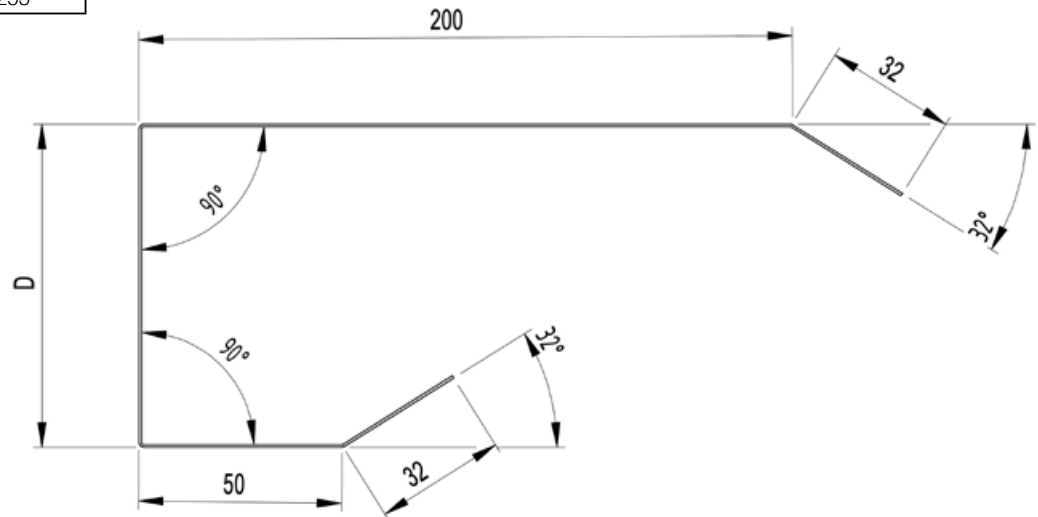

Rear Barge Capping Assembly Detail

15. INSTALLATION - FLASHINGS

DeltaCorroCorro™

DeltaCorroCorro Rear Barge Capping with Drip Guard

MATERIAL: 0.55mm G300

THICKNESS	D
75mm	103
100mm	128
125mm	153
150mm	178
175mm	203
200mm	228
225mm	253
250mm	278

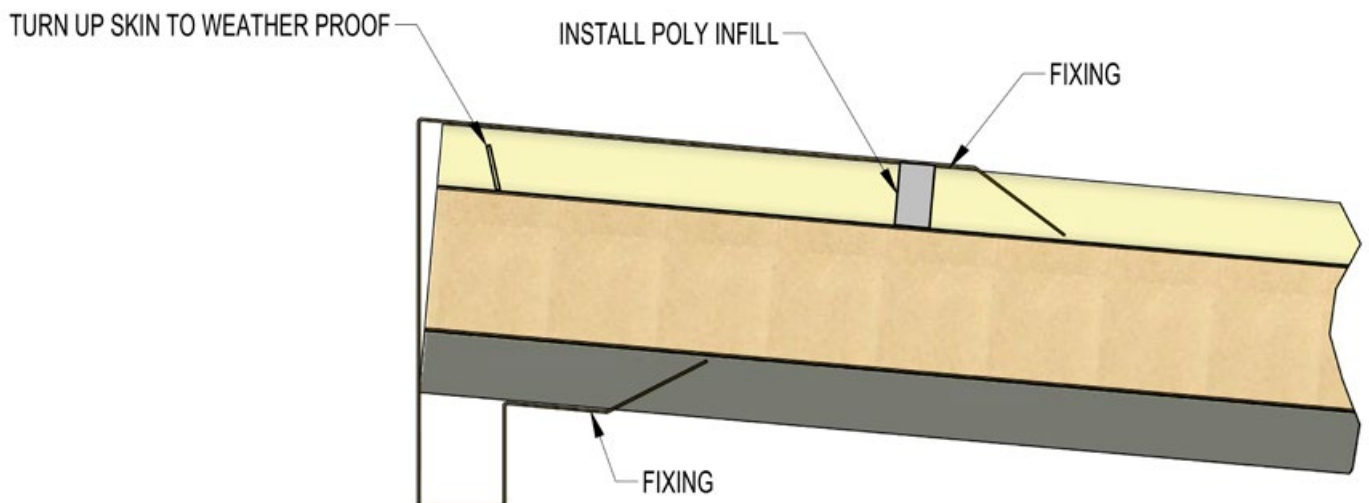
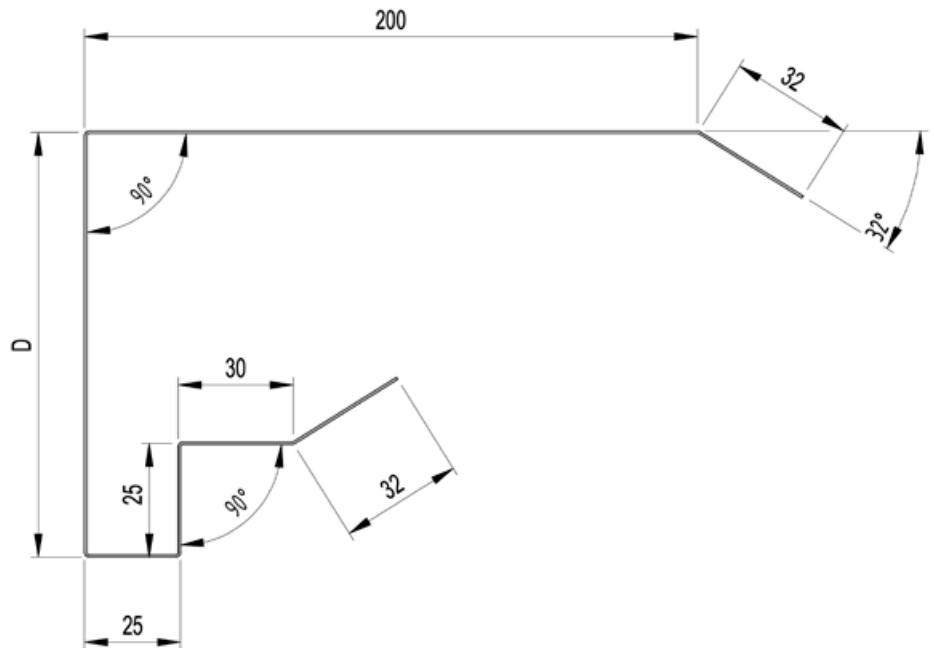

Rear Barge Capping Assembly Detail

15. INSTALLATION - FLASHINGS

DeltaCorroCorro™

DeltaCorroCorro Fascia Flashing

MATERIAL: 0.55mm G300

THICKNESS	D
75mm	82
100mm	107
125mm	132
150mm	157
175mm	182
200mm	207
225mm	232
250mm	257

ROOF PITCH FOR THIS ORDER		
ANGLE	STD	REQD
A	3°°

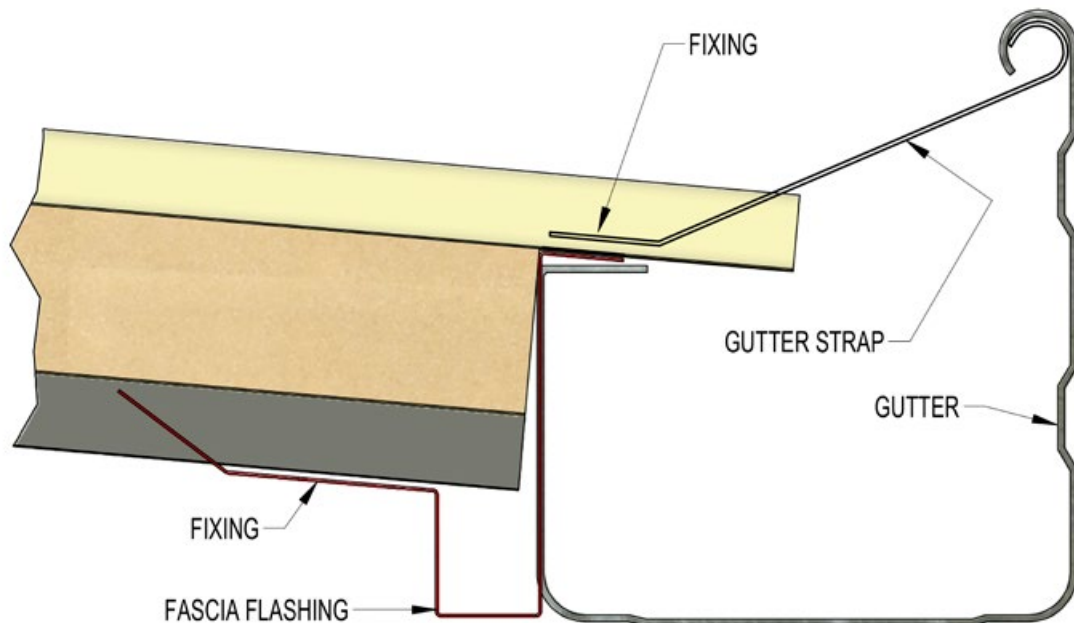
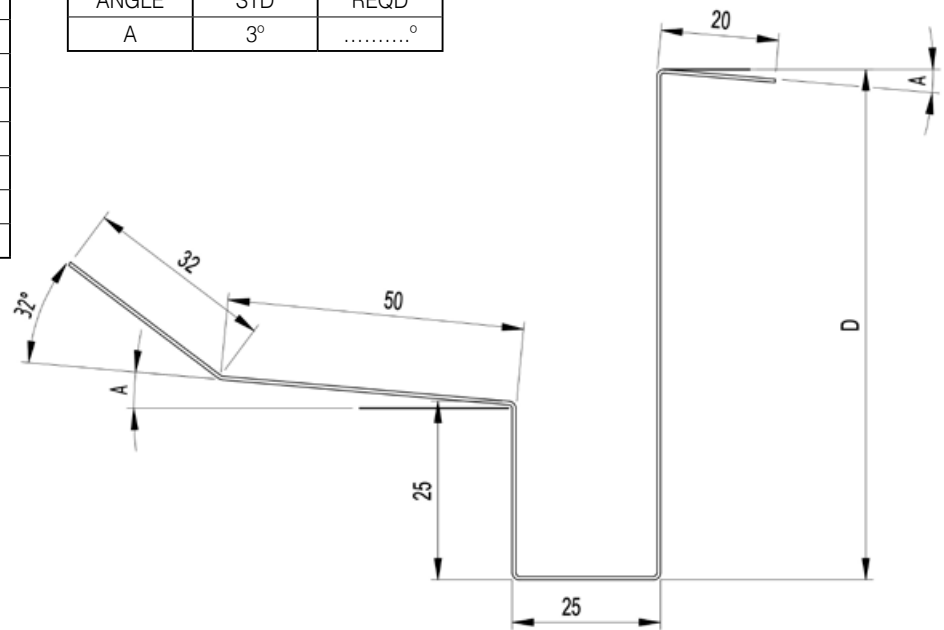

Fascia Flashing Assembly Detail

Flashing must be fitted in accordance with the relevant standard.

15. INSTALLATION - FLASHINGS

DeltaTrimTrim™

DeltaTrimTrim Receiver Channel

MATERIAL: 1.2mm BMT

THICKNESS	D
75mm	146
100mm	171
125mm	197
150mm	222
175mm	247
200mm	271

ROOF PITCH FOR THIS ORDER		
ANGLE	STD	REQD
A	2°°

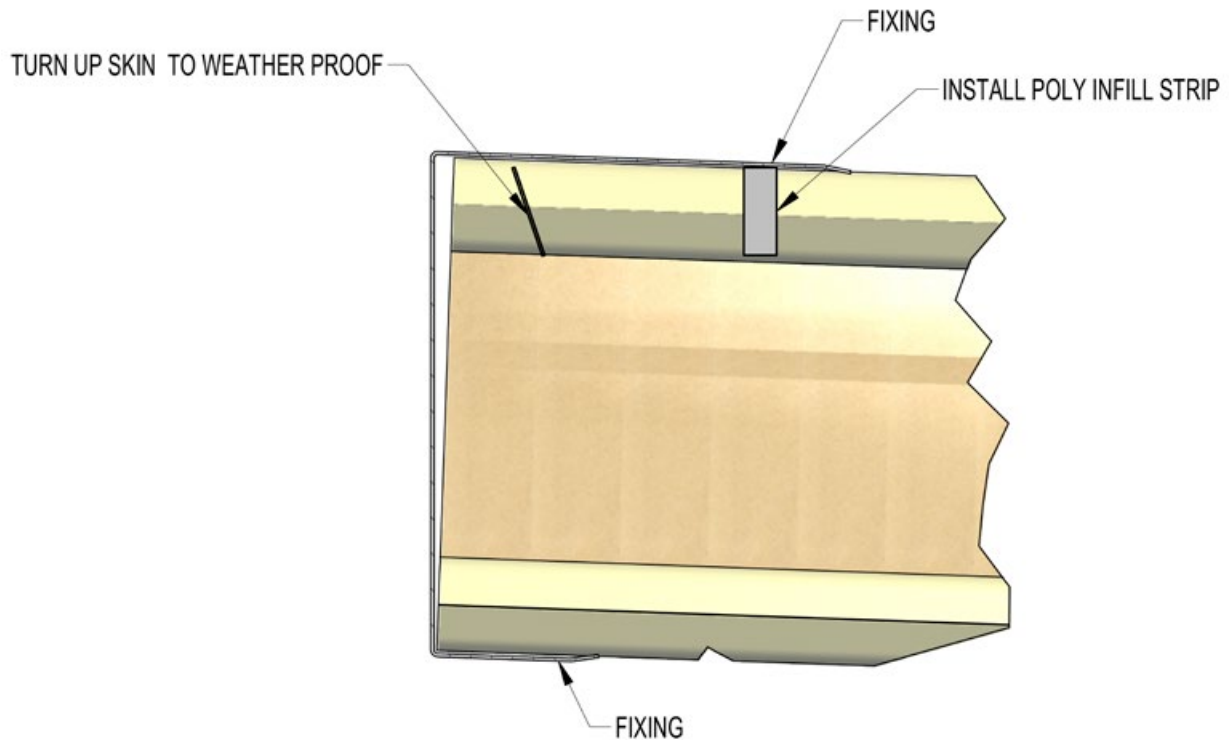
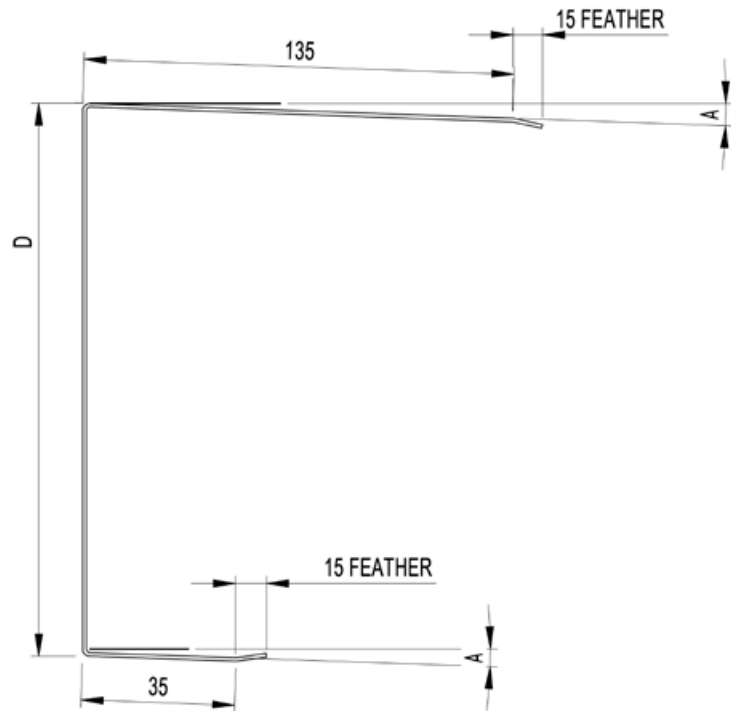

Receiver Channel Assembly Detail

Refer to Delta Insulated Patio Engineering & Construction Manual for Detail

15. INSTALLATION - FLASHINGS

DeltaTrimTrim™

DeltaTrimTrim Receiver Channel Flashing

MATERIAL: 0.55mm G300

$L = \text{NUMBER OF PANELS} + 50\text{mm}$

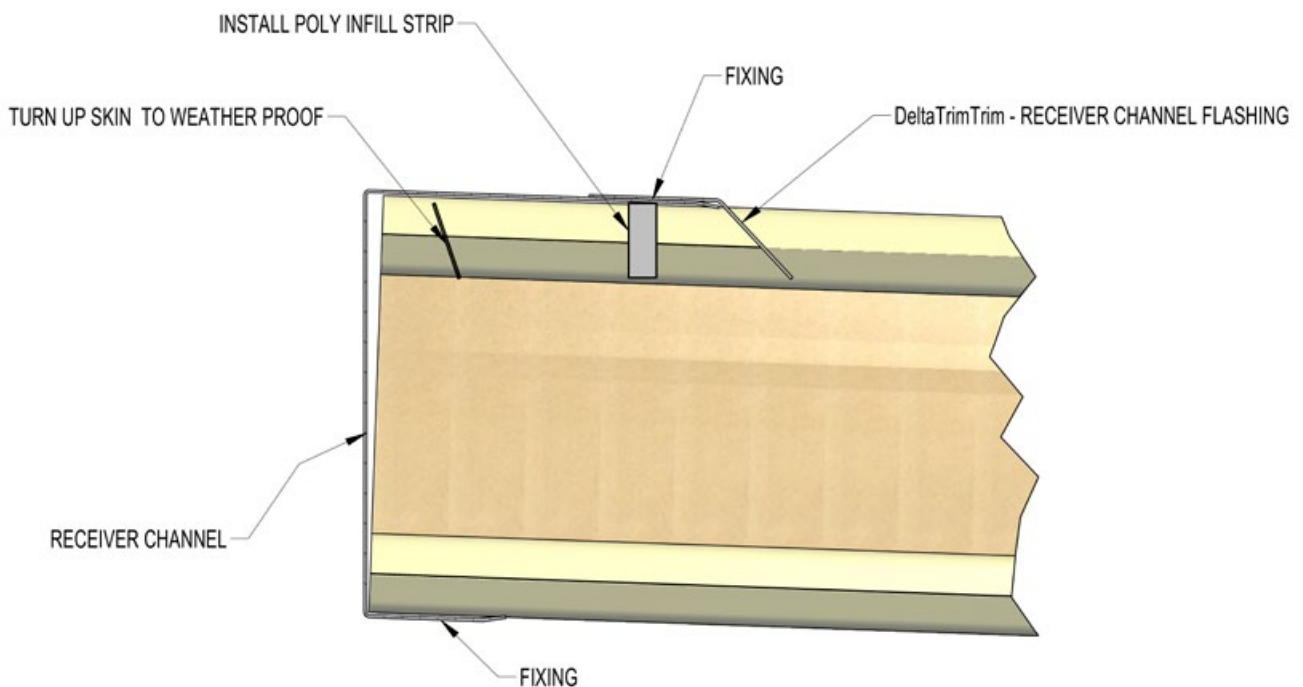
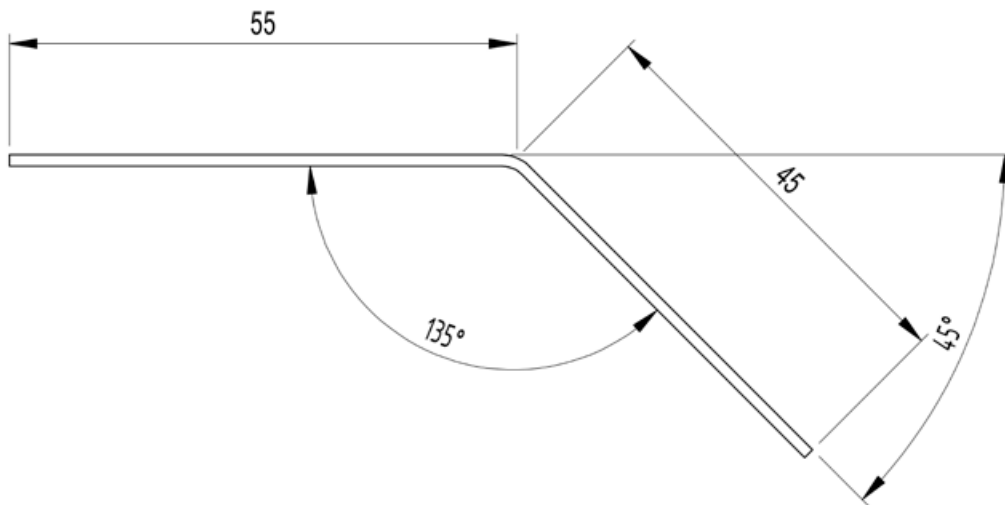

Apron Receiver Channel Flashing Assembly Detail

Flashing must be fitted in accordance with the relevant standard.

15. INSTALLATION - FLASHINGS

DeltaTrimTrim™

DeltaTrimTrim Apron Flashing

MATERIAL: 0.55mm G300

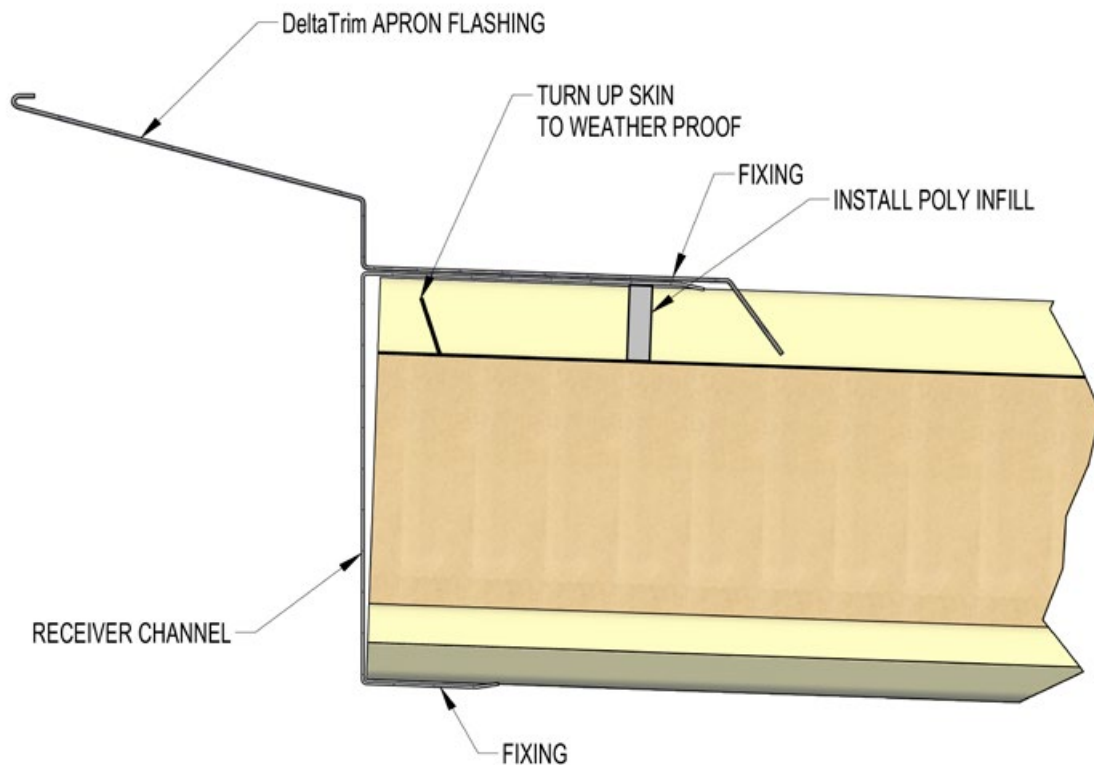
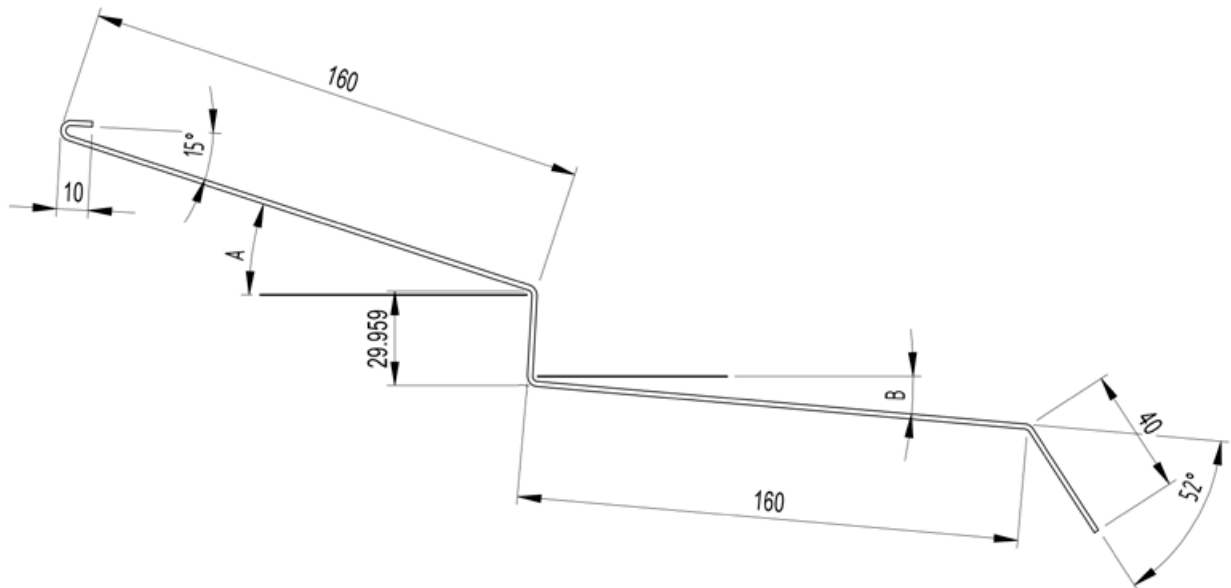

Apron Flashing Assembly Detail

Flashing must be fitted in accordance with the relevant standard.

15. INSTALLATION - FLASHINGS

DeltaTrimTrim™

DeltaTrimTrim Apron Flashing - B

MATERIAL: 0.55mm G300

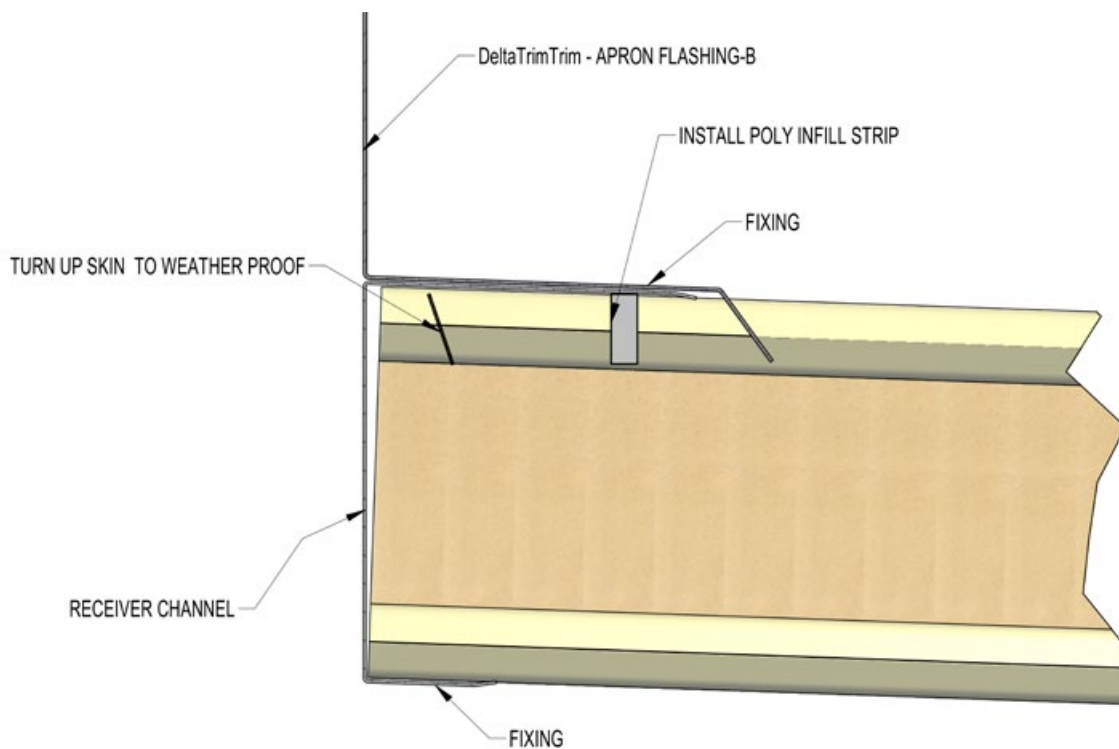
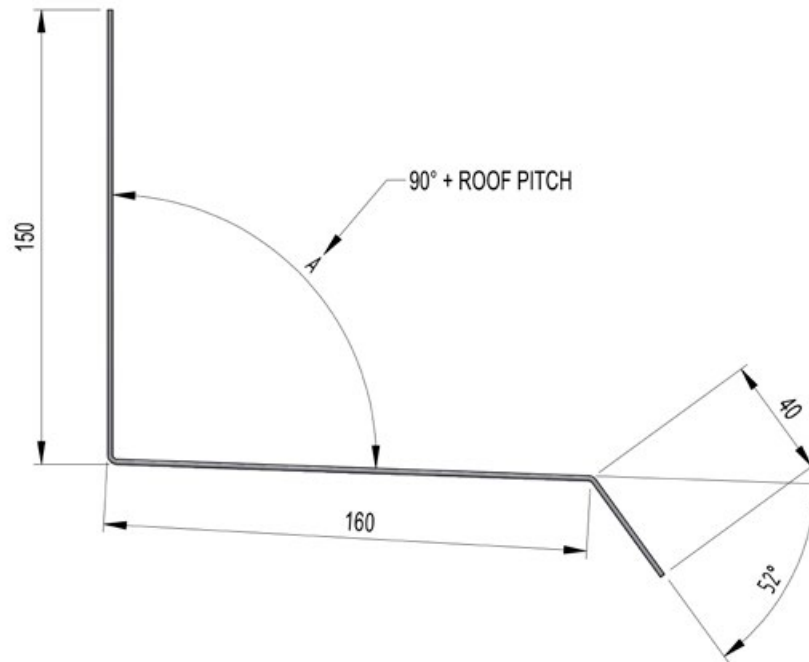

Apron Flashing Assembly Detail

Flashing must be fitted in accordance with the relevant standard.

15. INSTALLATION - FLASHINGS

DeltaTrimTrim™

DeltaTrimTrim Ridge Cap

MATERIAL: 0.55mm G300

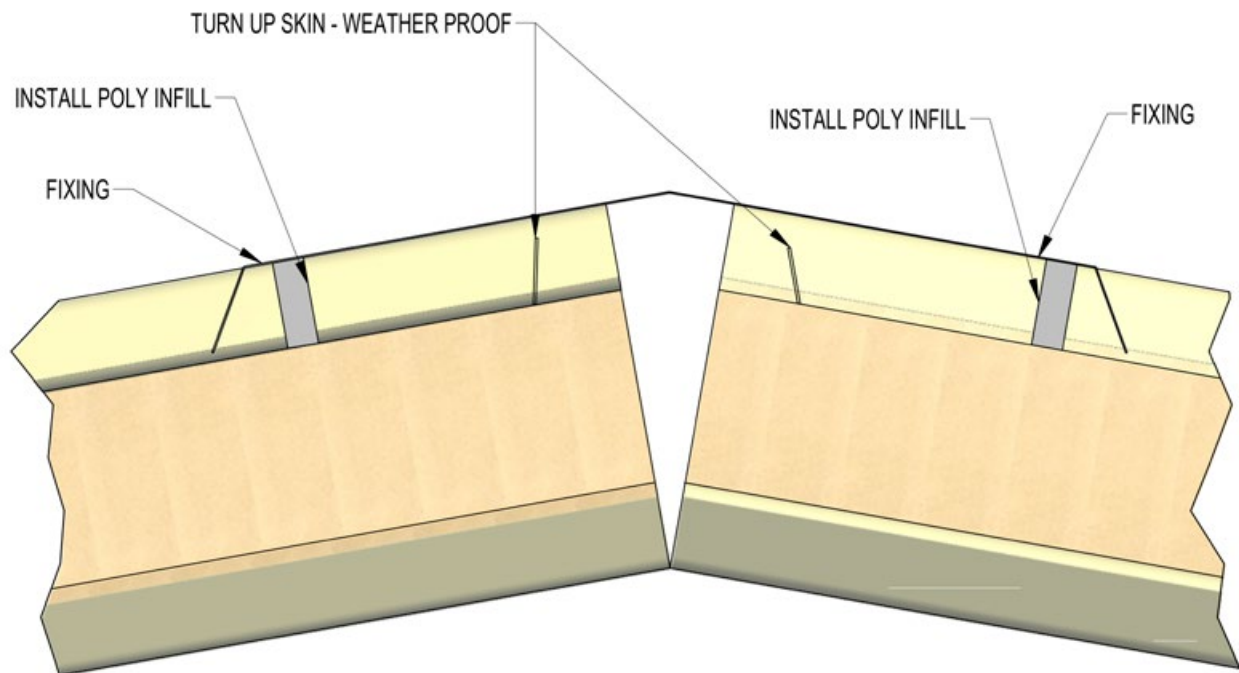
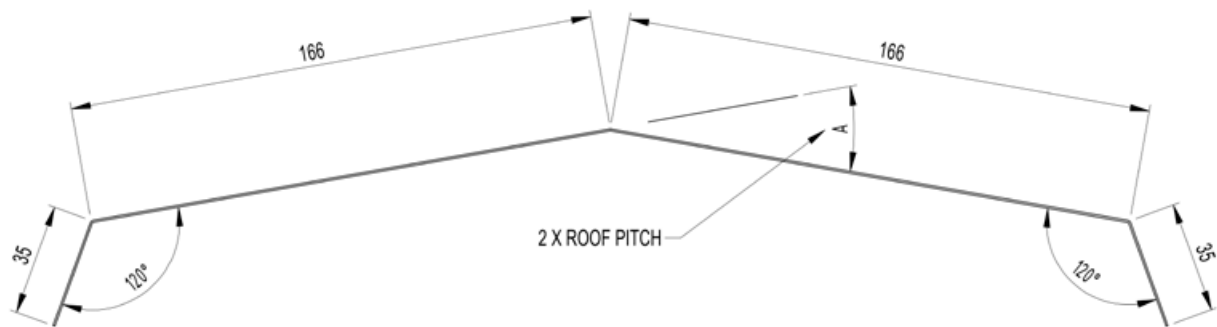

Ridge Cap Assembly Detail

Flashing must be fitted in accordance with the relevant standard.

15. INSTALLATION - FLASHINGS

DeltaTrimTrim™

DeltaTrimTrim Side Barge

MATERIAL: 0.55mm G300

THICKNESS	D
75mm	143
100mm	168
125mm	193
150mm	218
175mm	243
200mm	268

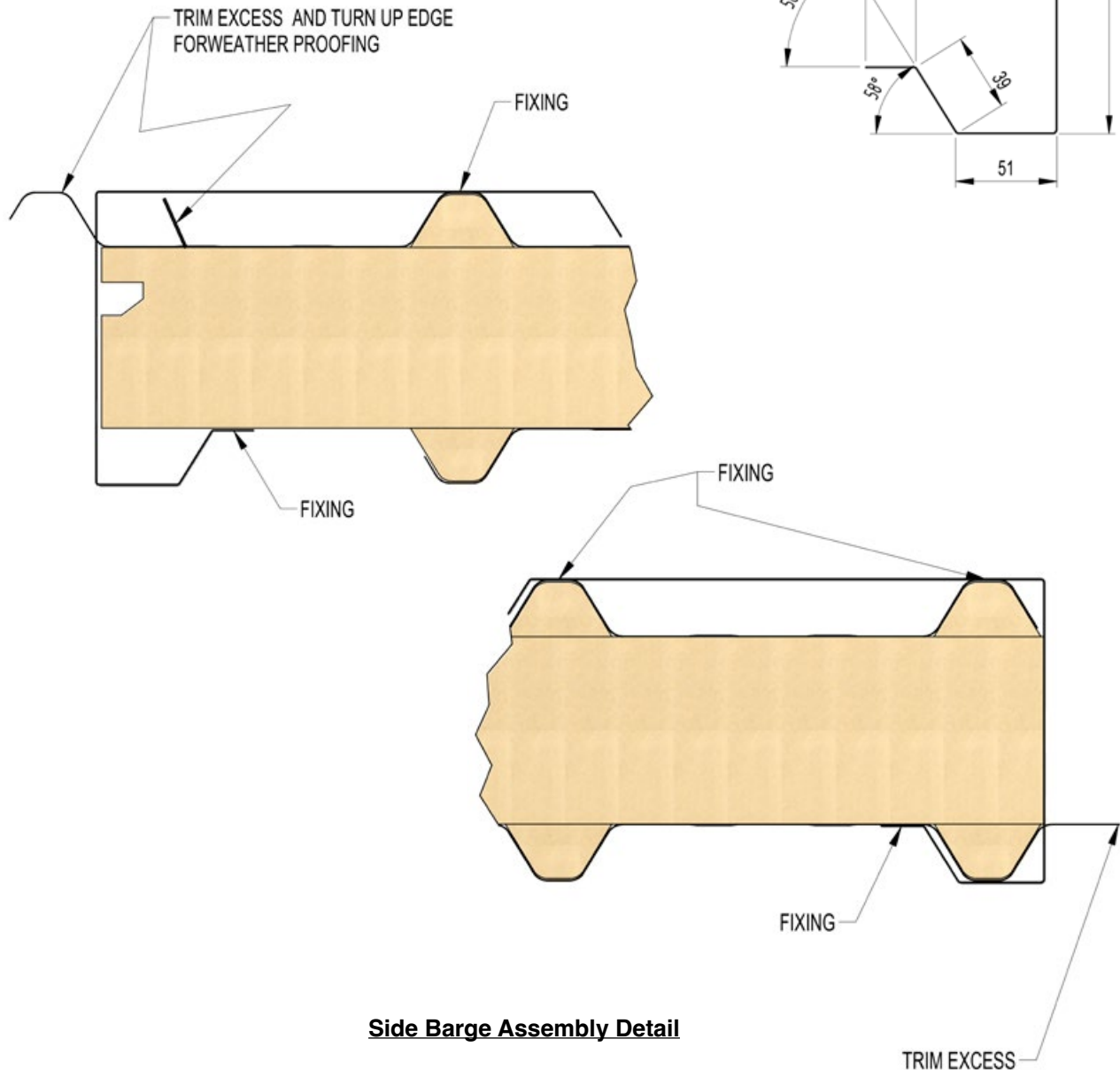
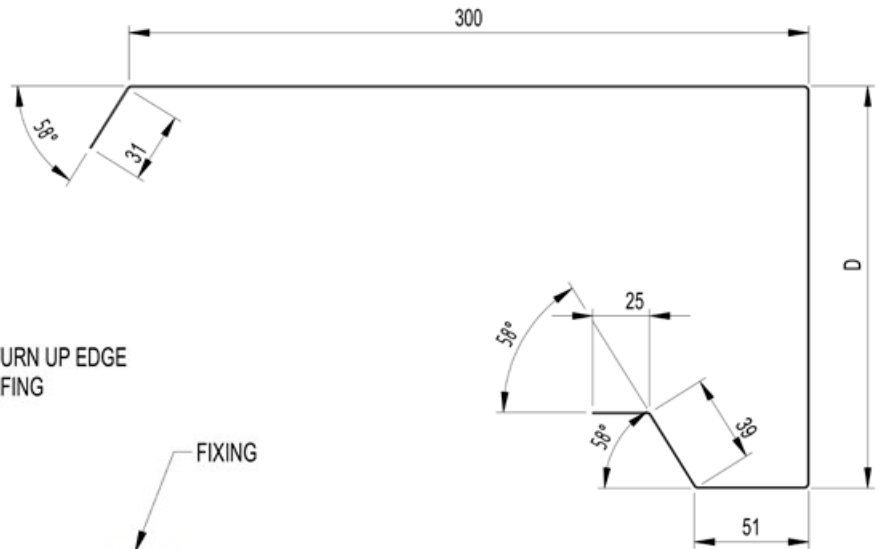

Side Barge Assembly Detail

Flashing must be fitted in accordance with the relevant standard.

15. INSTALLATION - FLASHINGS

DeltaTrimTrim™

DeltaTrimTrim Side Barge with Drip Guard

MATERIAL: 0.55mm G300

THICKNESS	D
75mm	161
100mm	186
125mm	211
150mm	236
175mm	261
200mm	286

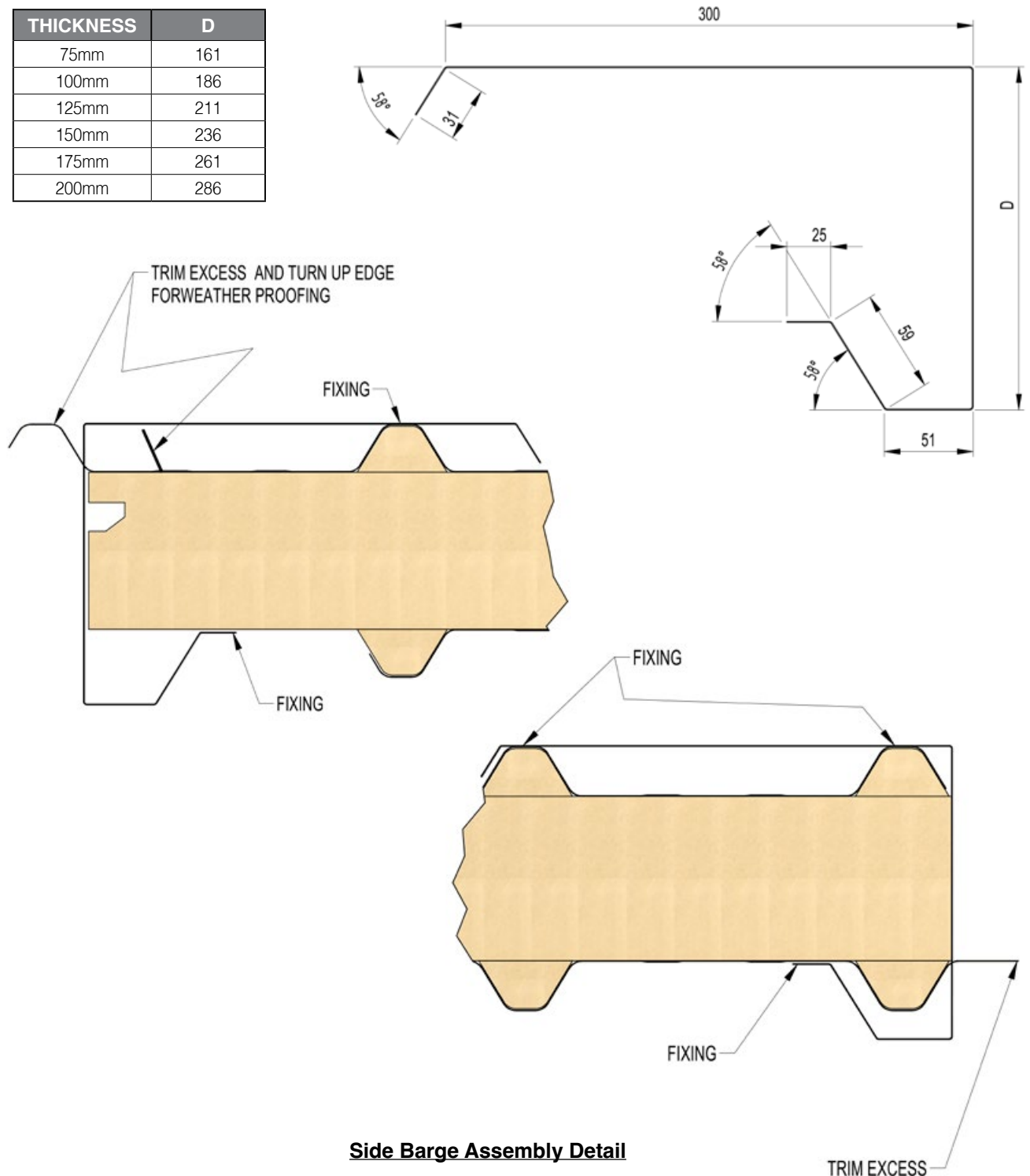

Side Barge Assembly Detail

Flashing must be fitted in accordance with the relevant standard.

15. INSTALLATION - FLASHINGS

DeltaTrimTrim™

DeltaTrimTrim Rear Barge Capping

MATERIAL: 0.55mm G300

THICKNESS	D
75mm	144
100mm	169
125mm	194
150mm	219
175mm	244
200mm	269

ROOF PITCH FOR THIS ORDER		
ANGLE	STD	REQD
A	2°°

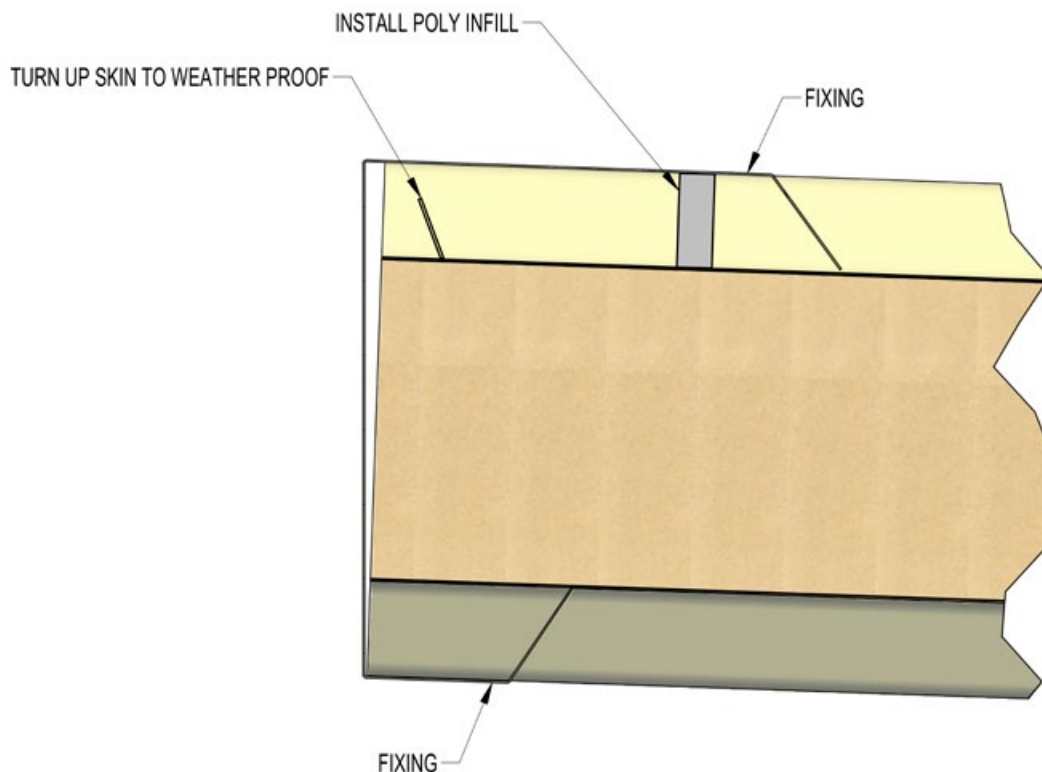
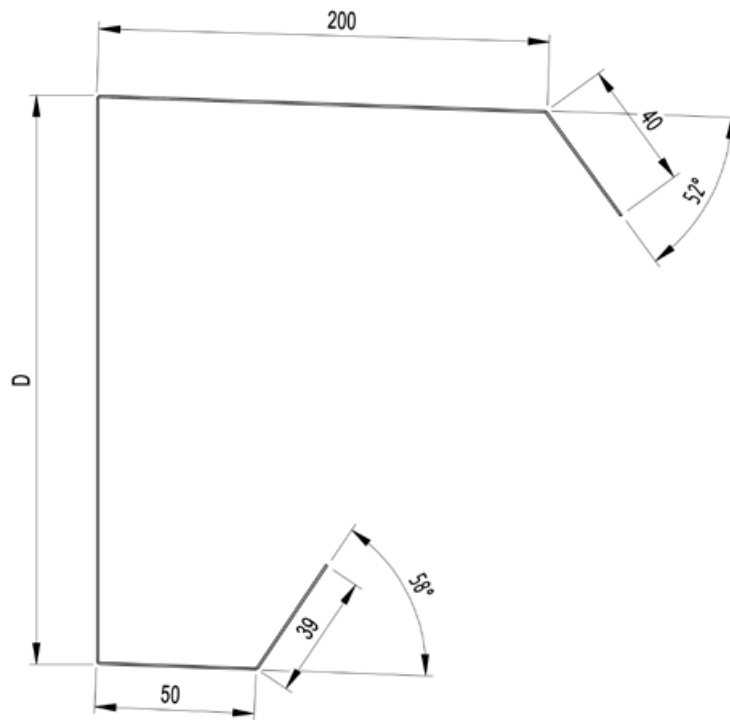

Rear Barge Capping Assembly Detail

15. INSTALLATION - FLASHINGS

DeltaTrimTrim™

DeltaTrimTrim Rear Barge Capping with Drip Guard

MATERIAL: 0.55mm G300

THICKNESS	D
75mm	161
100mm	186
125mm	211
150mm	236
175mm	261
200mm	286

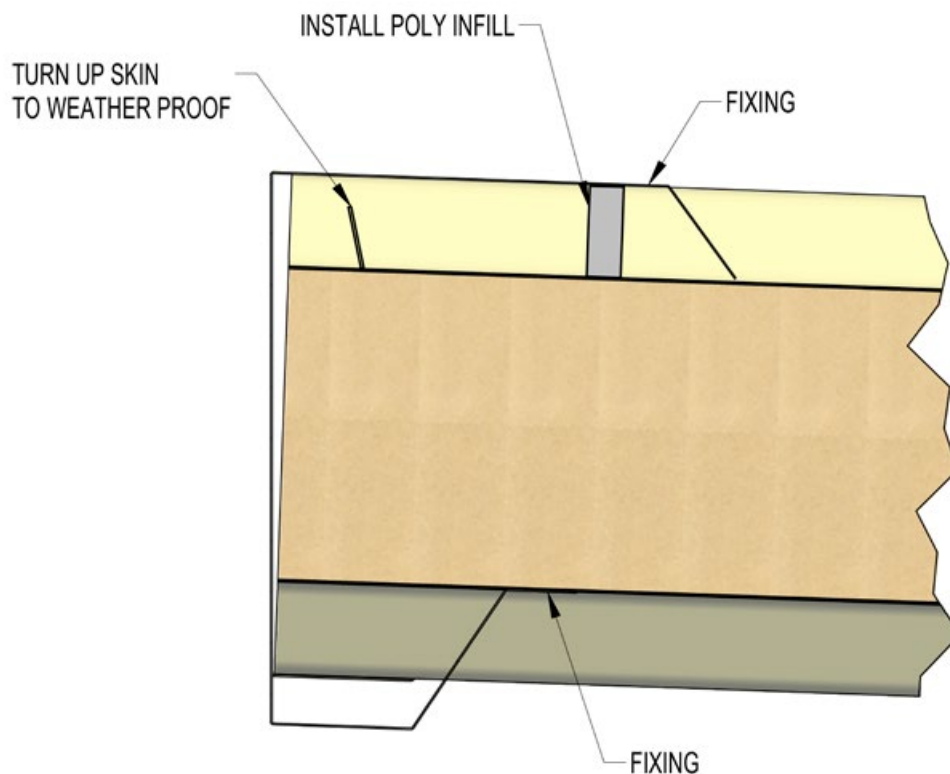
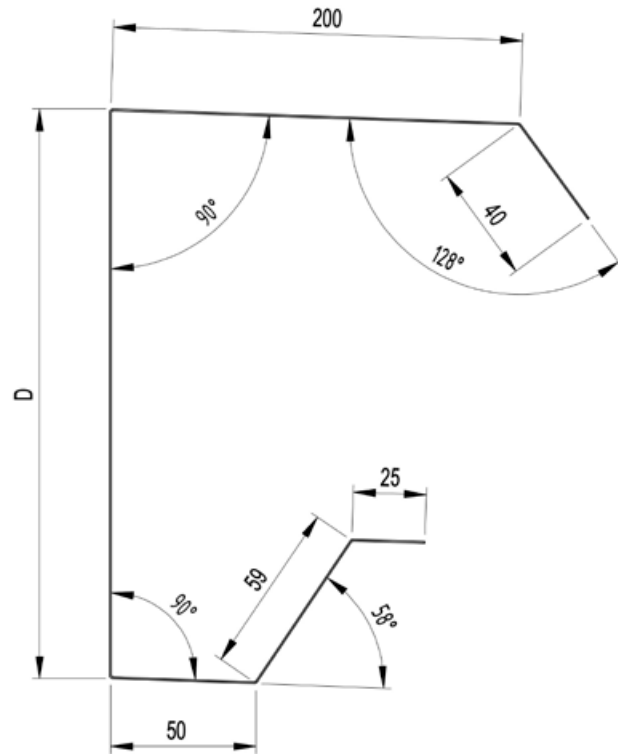

Rear Barge Capping Assembly Detail

15. INSTALLATION - FLASHINGS

DeltaTrimTrim™

DeltaTrimTrim Fascia Flashing

MATERIAL: 0.55mm G300

THICKNESS	D
75mm	107
100mm	132
125mm	157
150mm	182
175mm	207
200mm	232

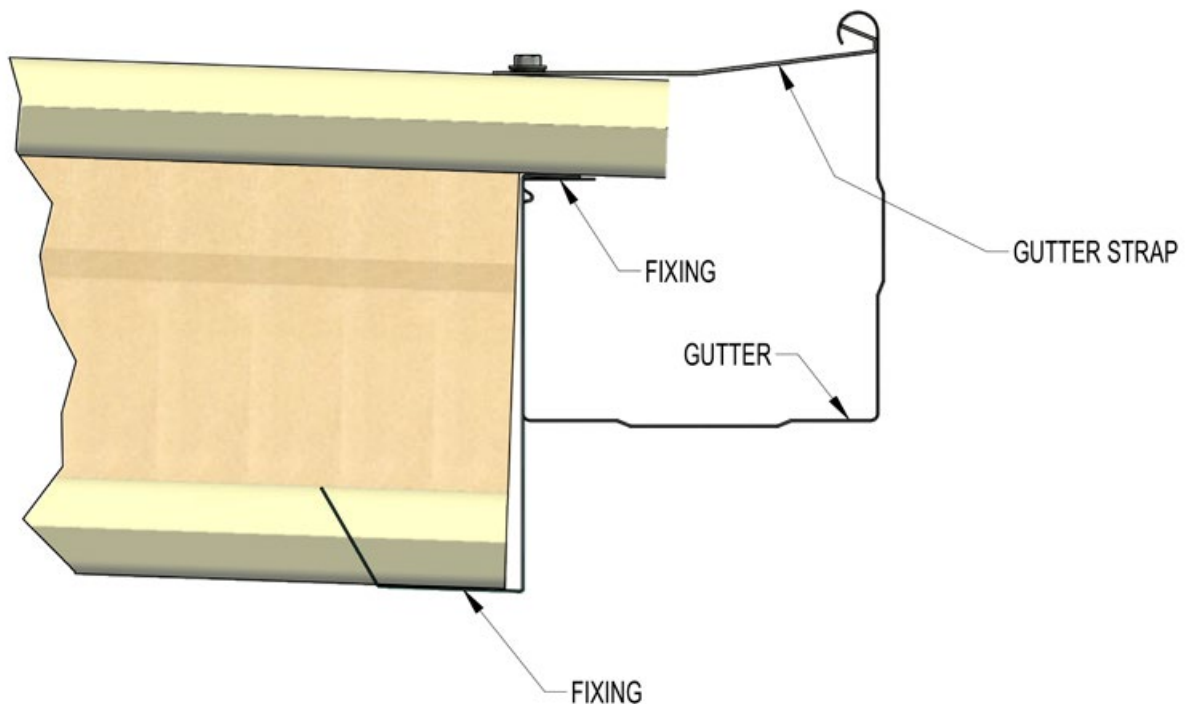
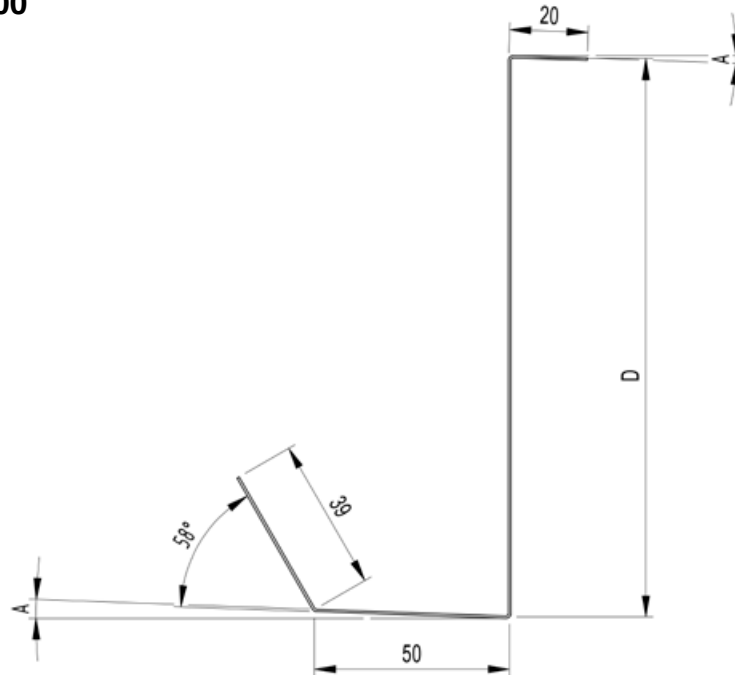

Fascia Flashing Assembly Detail

Flashing must be fitted in accordance with the relevant standard.

15. INSTALLATION - FLASHINGS

DeltaTrimTrim™

DeltaTrimTrim Fascia Flashing with Drip Guard

MATERIAL: 0.55mm G30C

THICKNESS	D
75mm	126
100mm	151
125mm	176
150mm	201
175mm	226
200mm	251

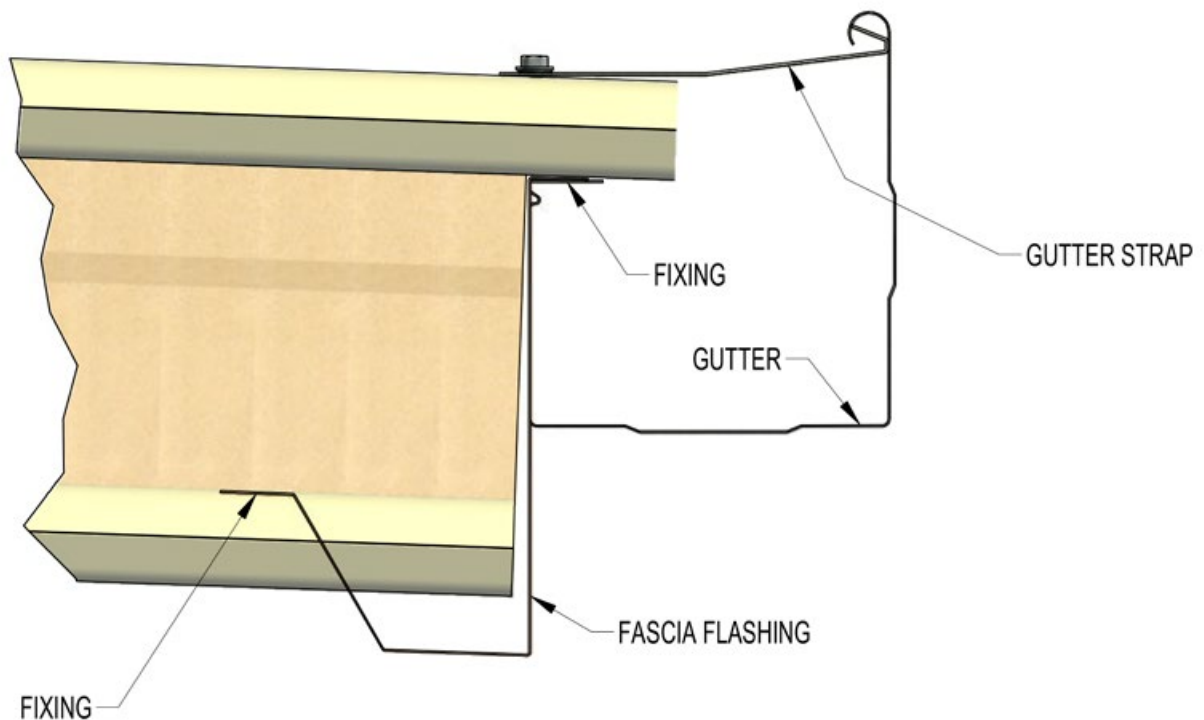
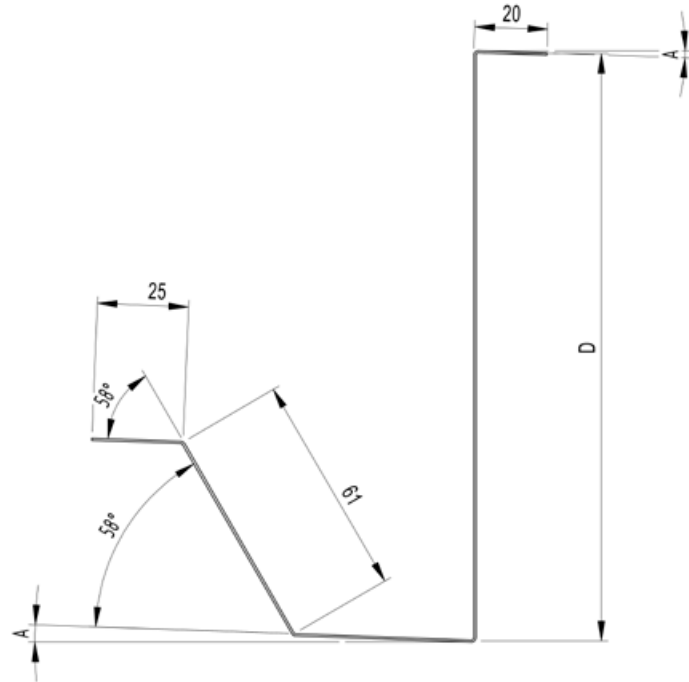

Fascia Flashing Assembly Detail

Flashing must be fitted in accordance with the relevant standard.

15. INSTALLATION - FLASHINGS

DeltaTrimCorro™

DeltaTrimCorro Receiver Channel

MATERIAL: 1.2mm BMT

THICKNESS	D
75mm	130
100mm	155
125mm	180
150mm	205
175mm	230
200mm	255

ROOF PITCH FOR THIS ORDER		
ANGLE	STD	REQD
A	3°°

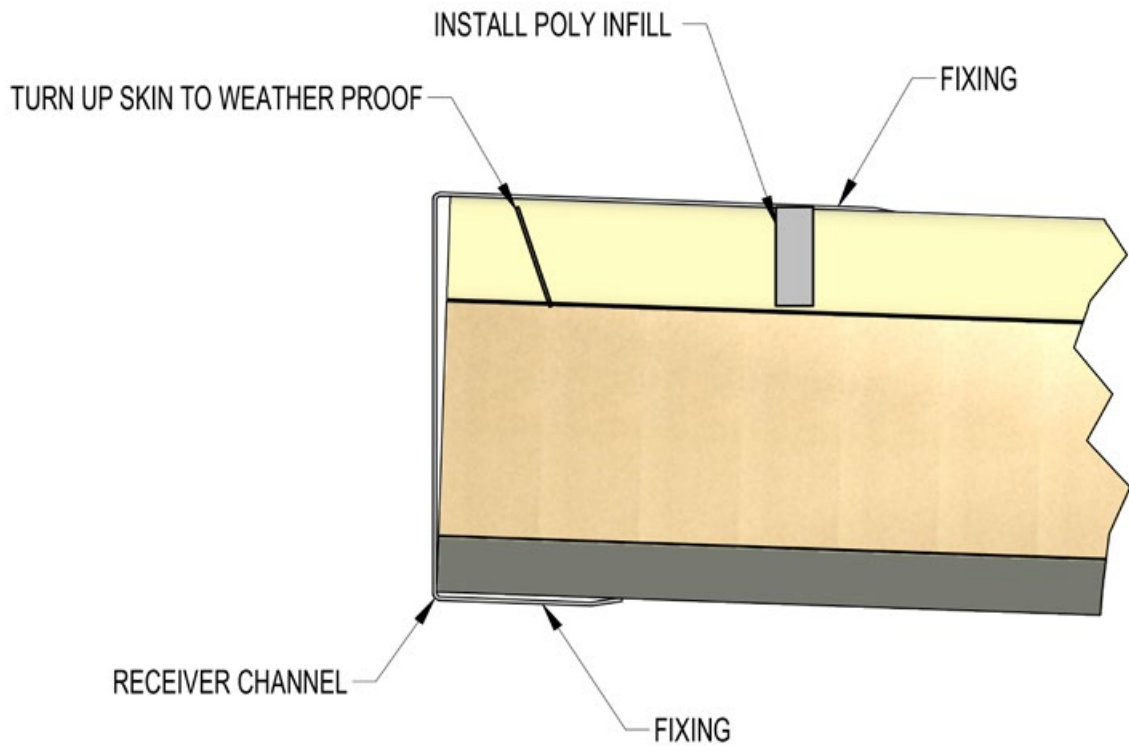
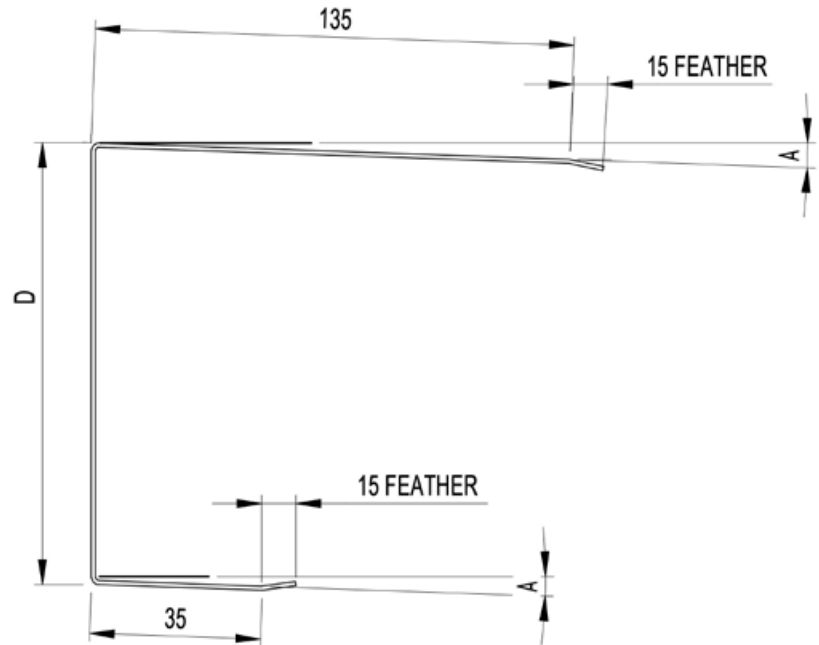

Receiver Channel Assembly Detail

Flashing must be fitted in accordance with the relevant standard.

15. INSTALLATION - FLASHINGS

DeltaTrimCorro™

DeltaTrimCorro Receiver Channel Flashing

MATERIAL: 0.55mm G300

$L = \text{NUMBER OF PANELS} + 50\text{mm}$

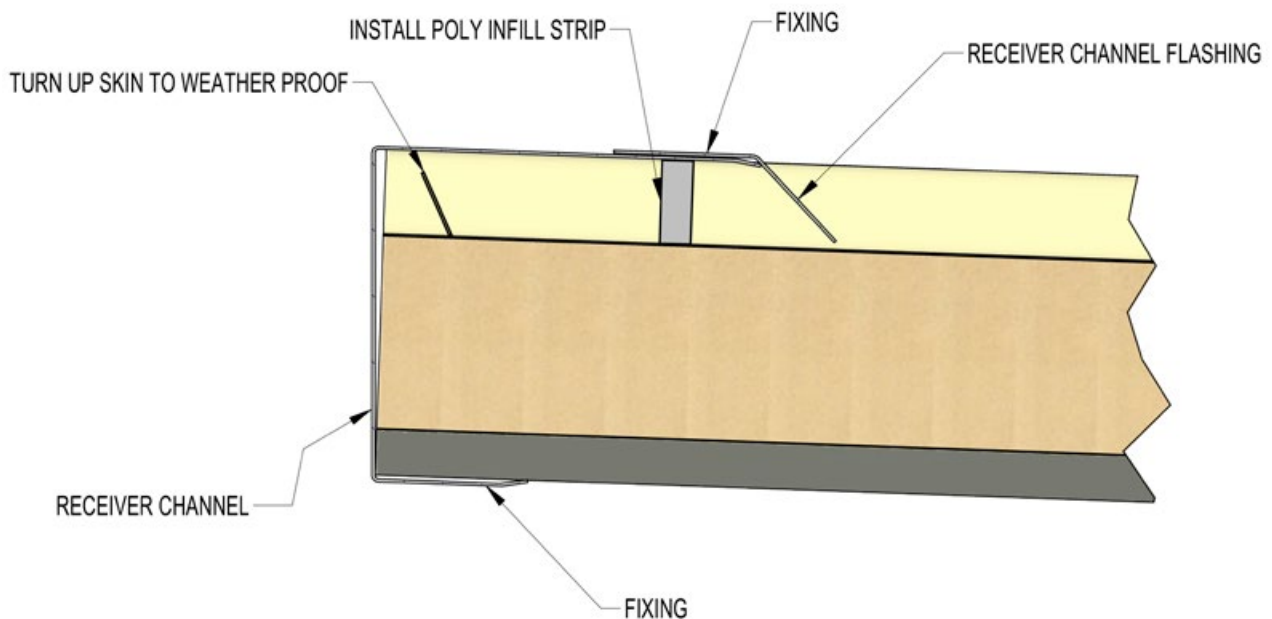
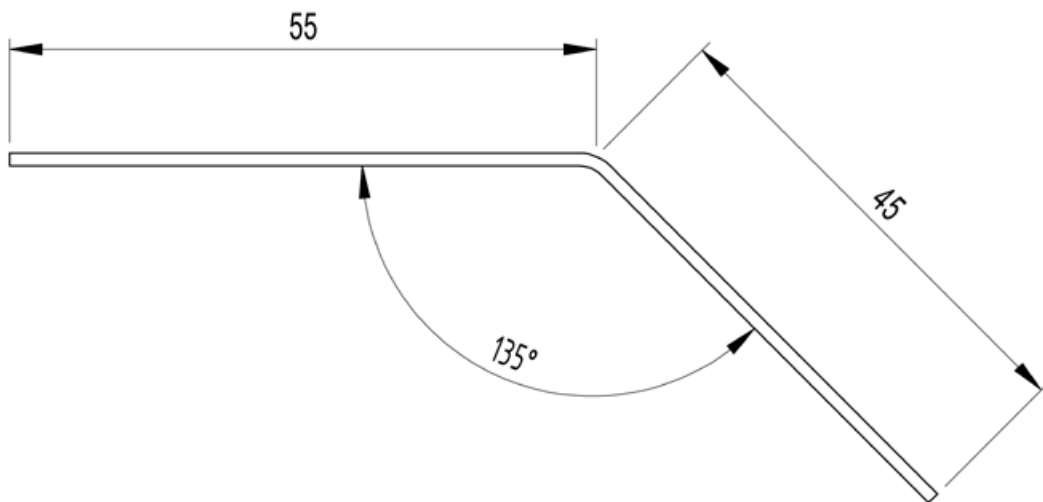

Receiver Channel Flashing Assembly Detail

Flashing must be fitted in accordance with the relevant standard.

15. INSTALLATION - FLASHINGS

DeltaTrimCorro™

DeltaTrimCorro Apron Flashing

MATERIAL: 0.55mm G300

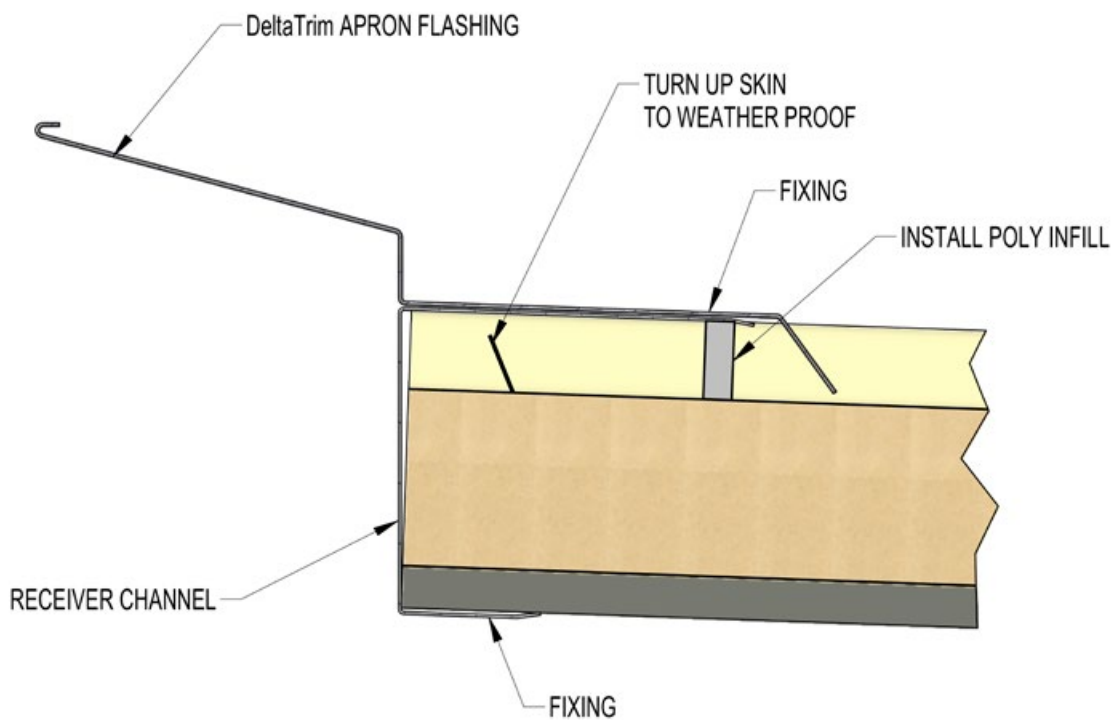
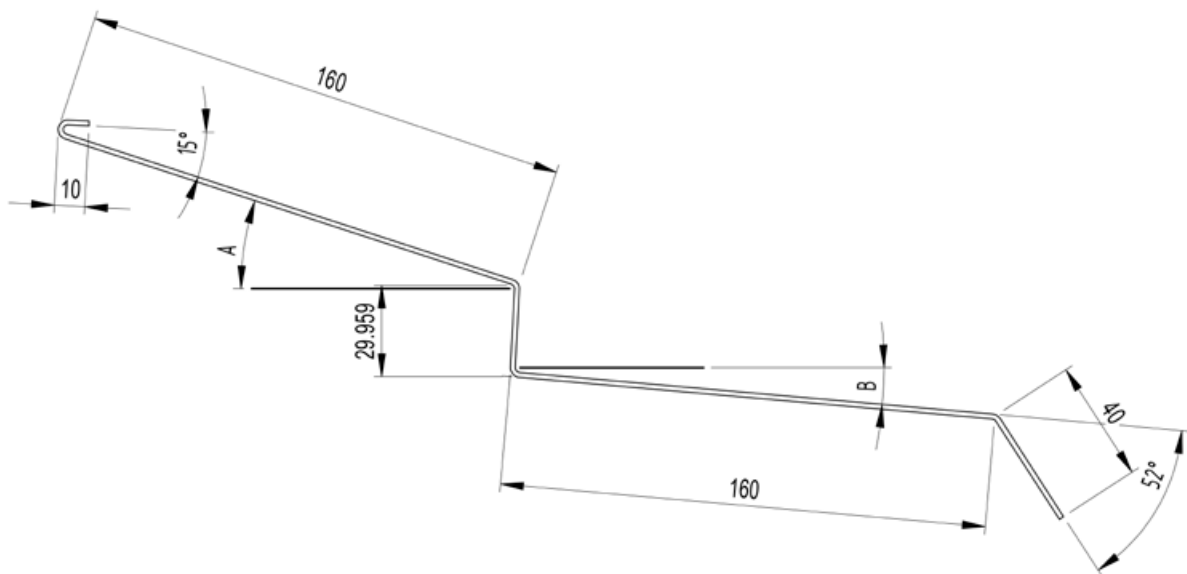

Apron Flashing Assembly Detail

Flashing must be fitted in accordance with the relevant standard.

15. INSTALLATION - FLASHINGS

DeltaTrimCorro™

DeltaTrimCorro Apron Flashing - B

MATERIAL: 0.55mm G300

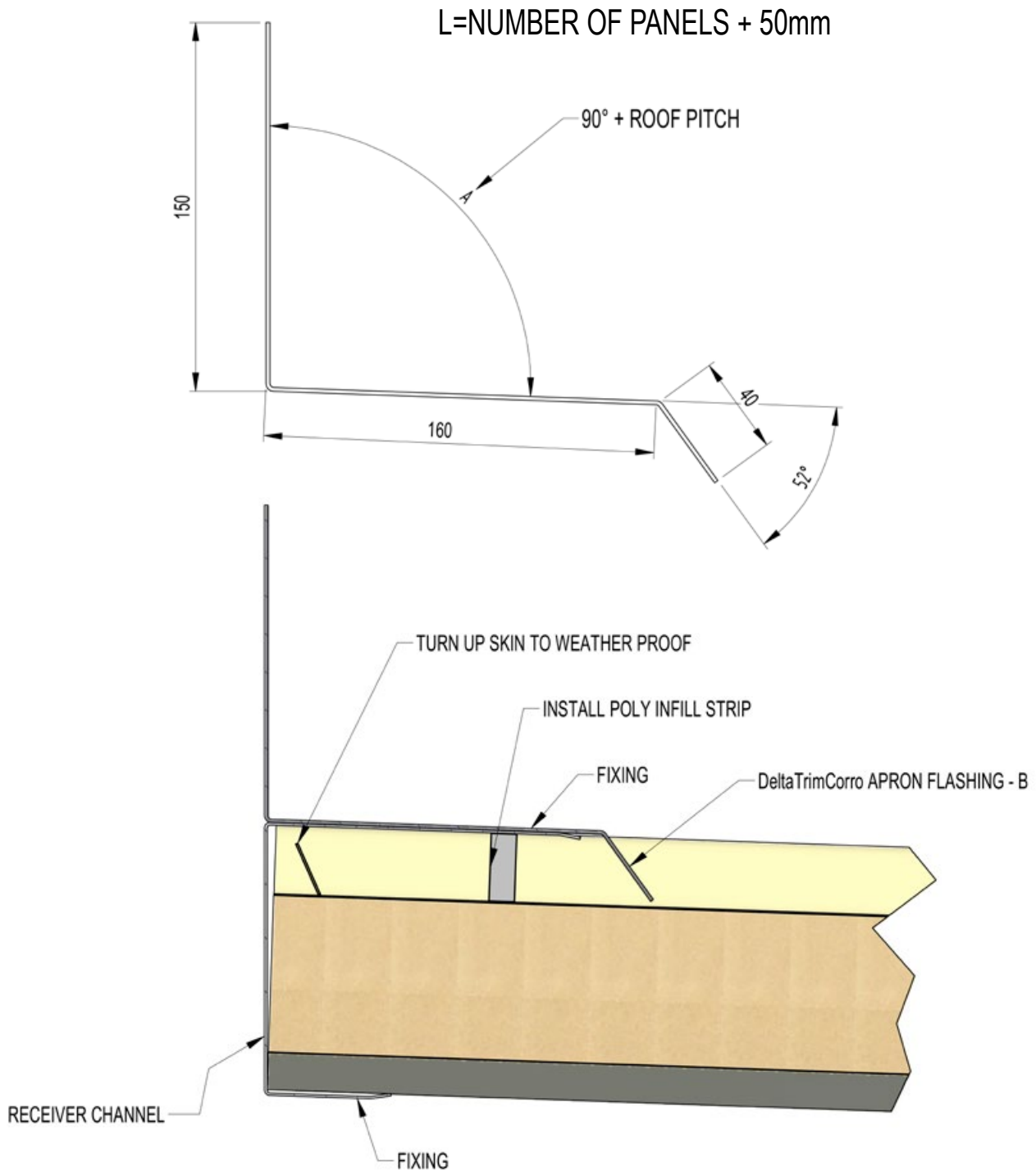

Apron Flashing Assembly Detail

Flashing must be fitted in accordance with the relevant standard.

15. INSTALLATION - FLASHINGS

DeltaTrimCorro™

DeltaTrimCorro Ridge Cap - Trim

MATERIAL: 0.55mm G300

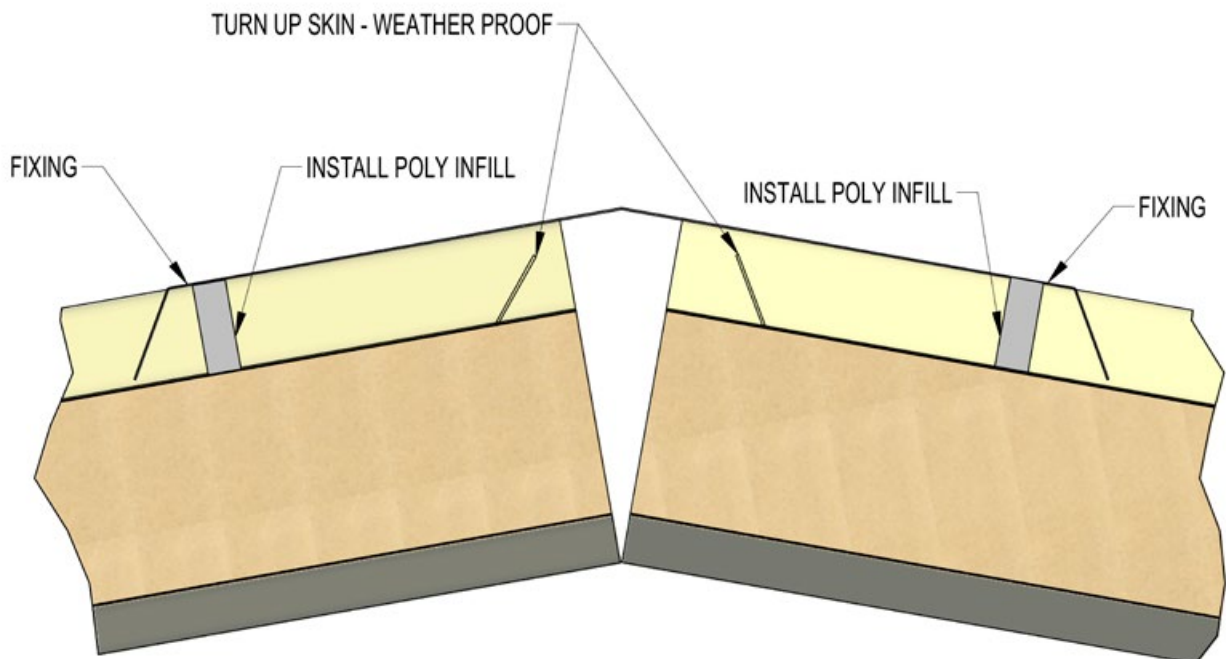
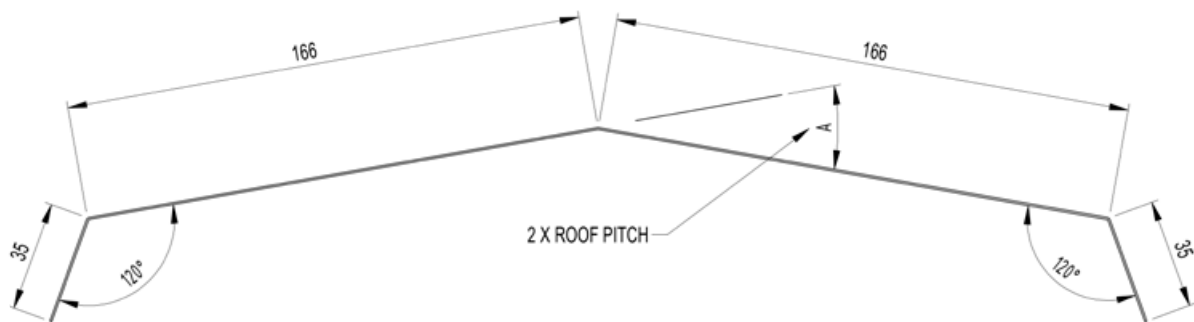

Ridge Cap - Trim Assembly Detail

Flashing must be fitted in accordance with the relevant standard.

15. INSTALLATION - FLASHINGS

DeltaTrimCorro™

DeltaTrimCorro Ridge Cap - Corro

MATERIAL: 0.55mm G300

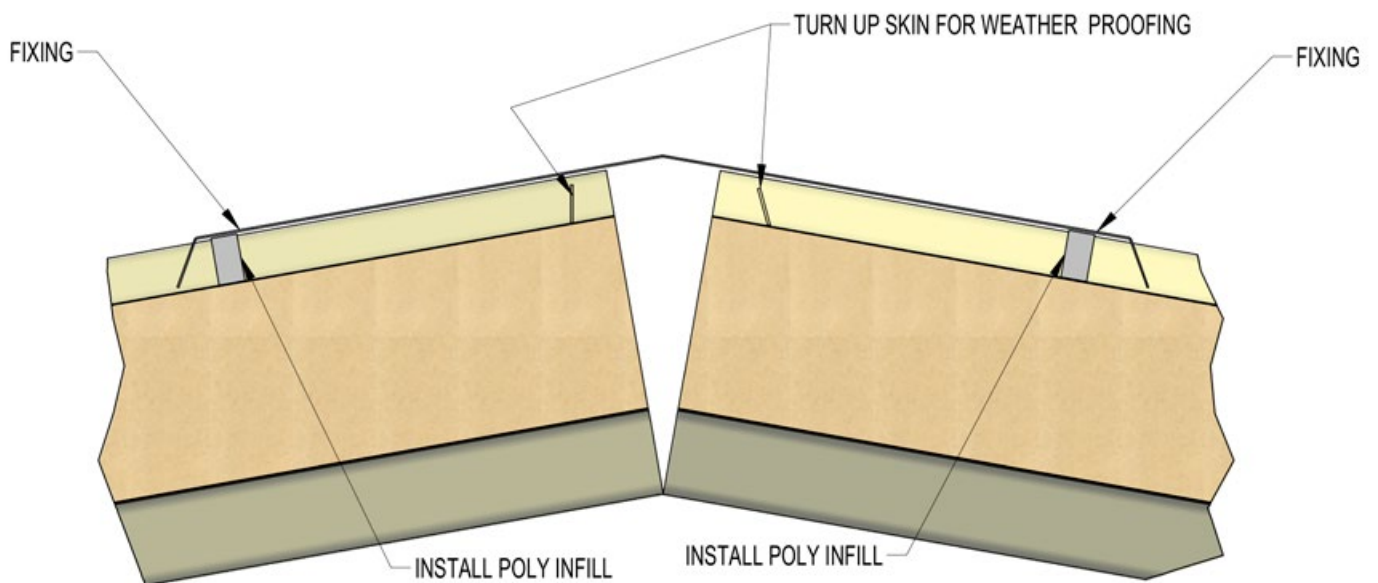
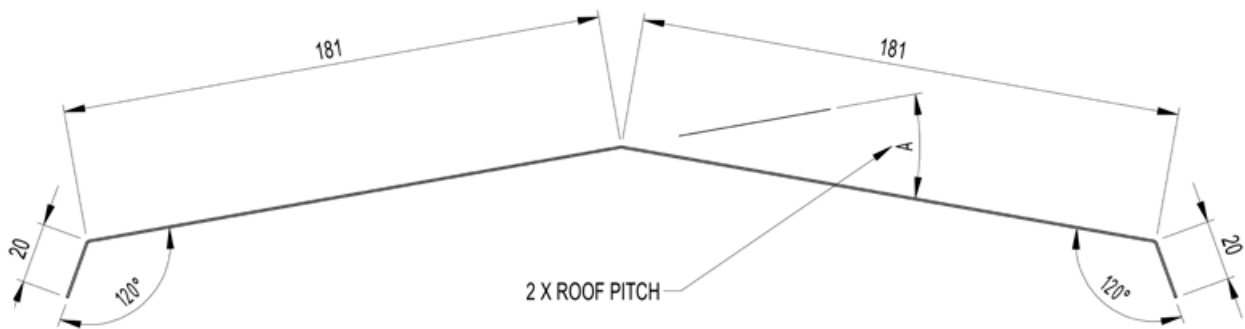

Ridge Cap - Corro Assembly Detail

Flashing must be fitted in accordance with the relevant standard.

15. INSTALLATION - FLASHINGS

DeltaTrimCorro™

DeltaTrimCorro Side Barge

MATERIAL: 0.55mm G300

THICKNESS	D
75mm	127
100mm	152
125mm	177
150mm	202
175mm	227
200mm	252

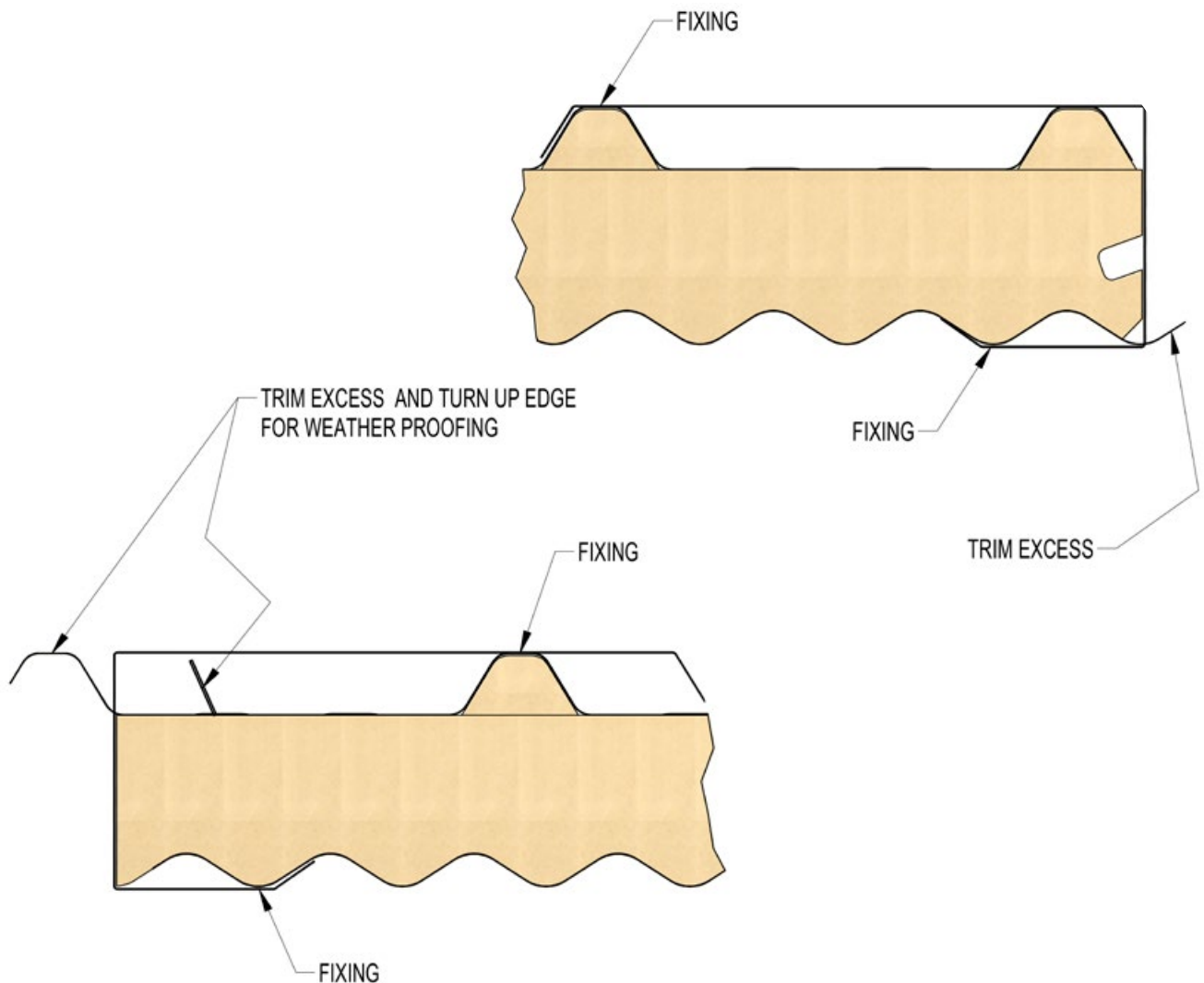
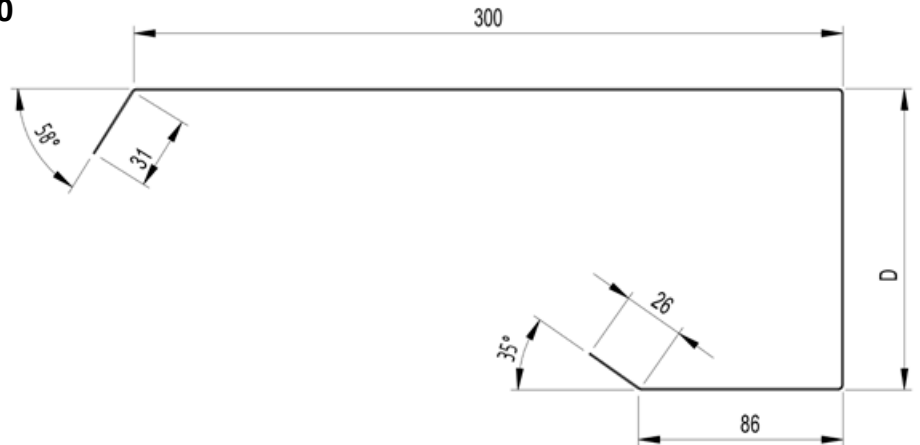

Side Barge Assembly Detail

Flashing must be fitted in accordance with the relevant standard.

15. INSTALLATION - FLASHINGS

DeltaTrimCorro™

DeltaTrimCorro Side Barge with Drip Guard

MATERIAL: 0.55mm G30ⁿ

THICKNESS	D
75mm	157
100mm	182
125mm	207
150mm	232
175mm	257
200mm	282

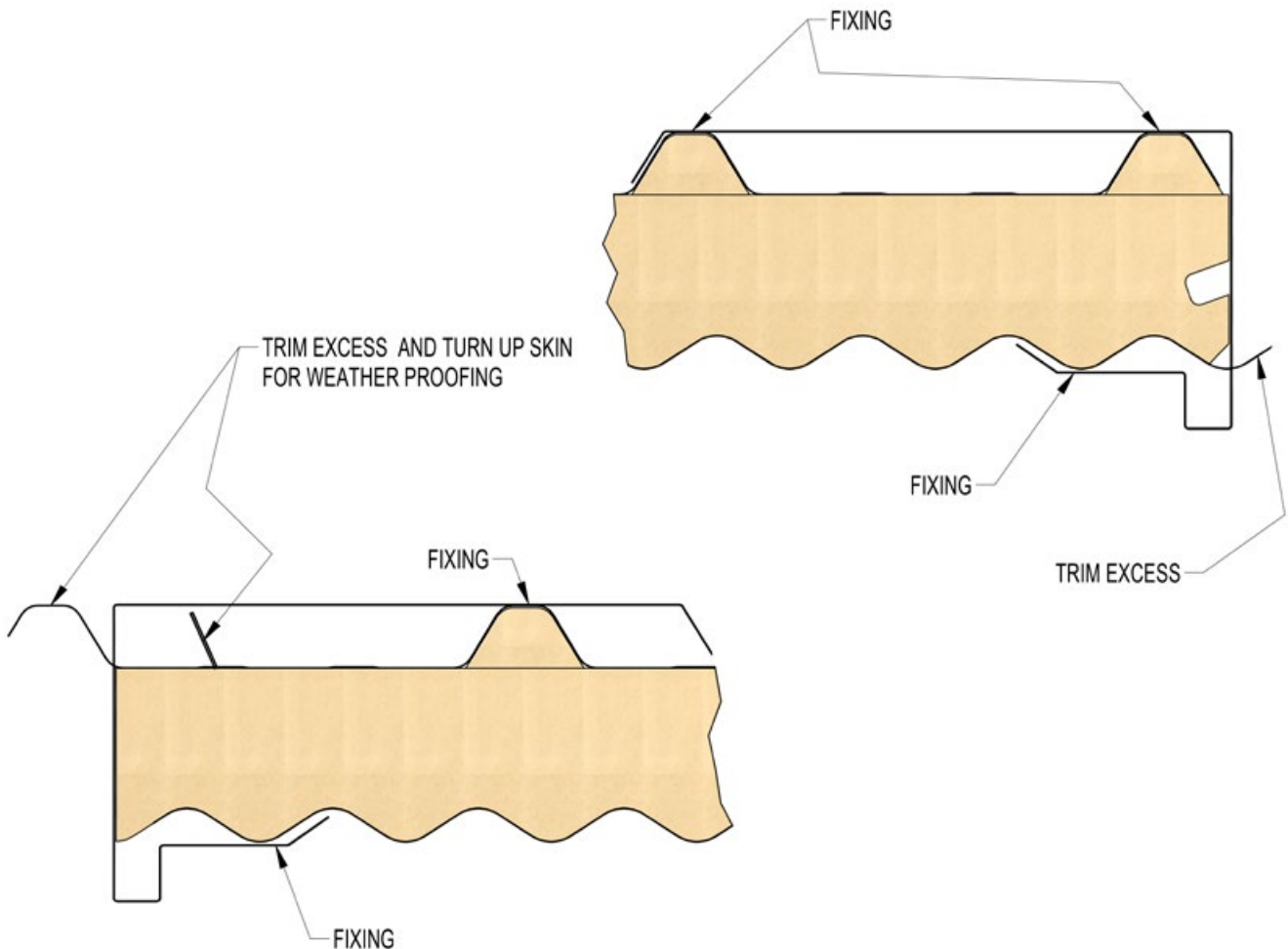
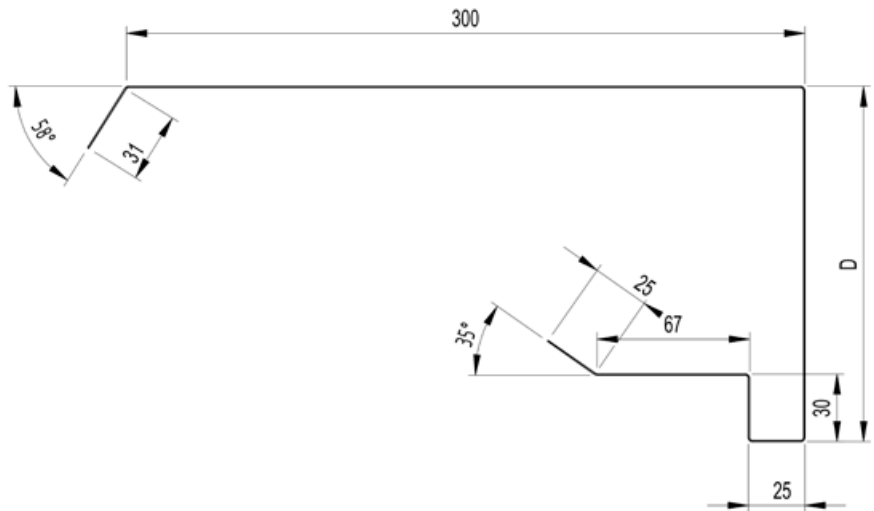

Side Barge Assembly Detail

Flashing must be fitted in accordance with the relevant standard.

15. INSTALLATION - FLASHINGS

DeltaTrimCorro™

DeltaTrimCorro Rear Barge Capping

MATERIAL: 0.55mm G300

THICKNESS	D
75mm	127
100mm	152
125mm	177
150mm	202
175mm	227
200mm	252

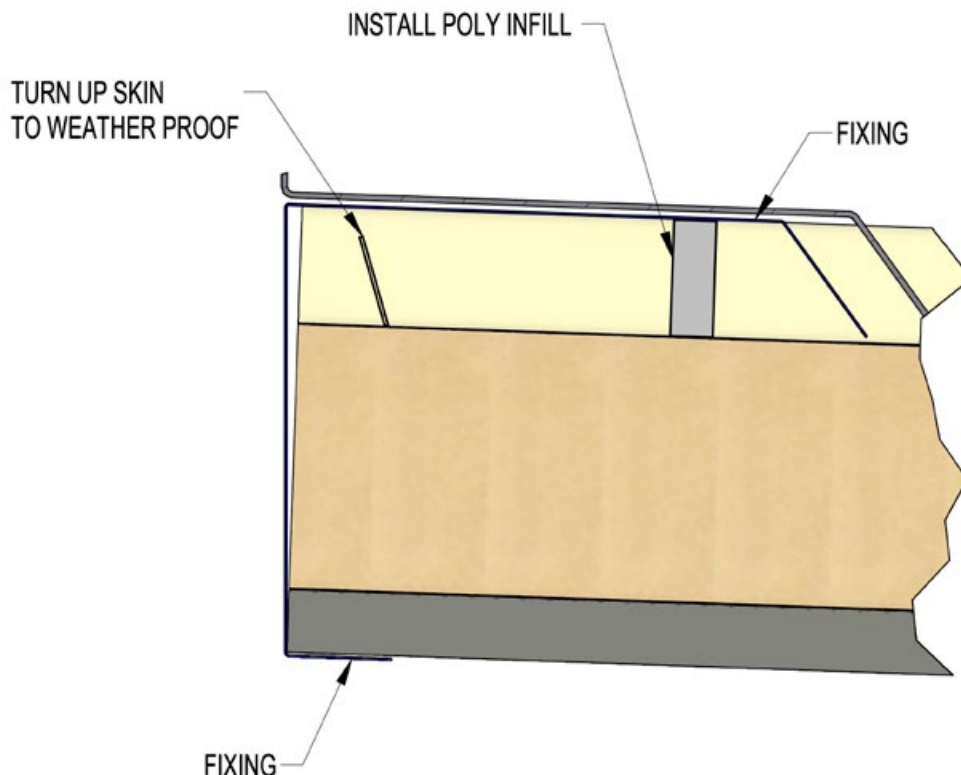
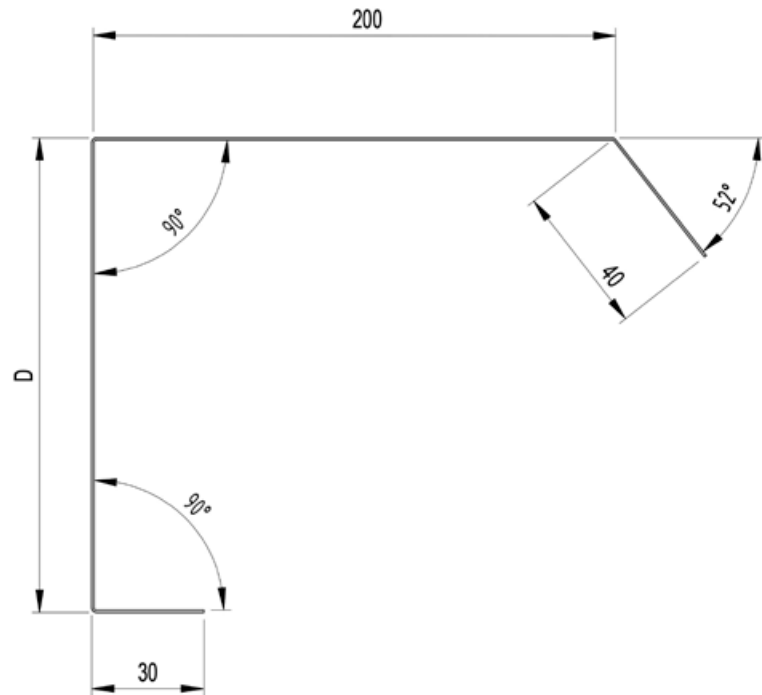

Rear Barge Capping Assembly Detail

15. INSTALLATION - FLASHINGS

DeltaTrimCorro™

DeltaTrimCorro Rear Barge Capping with Drip Guard

MATERIAL: 0.55mm G300

THICKNESS	D
75mm	152
100mm	177
125mm	202
150mm	227
175mm	252
200mm	277

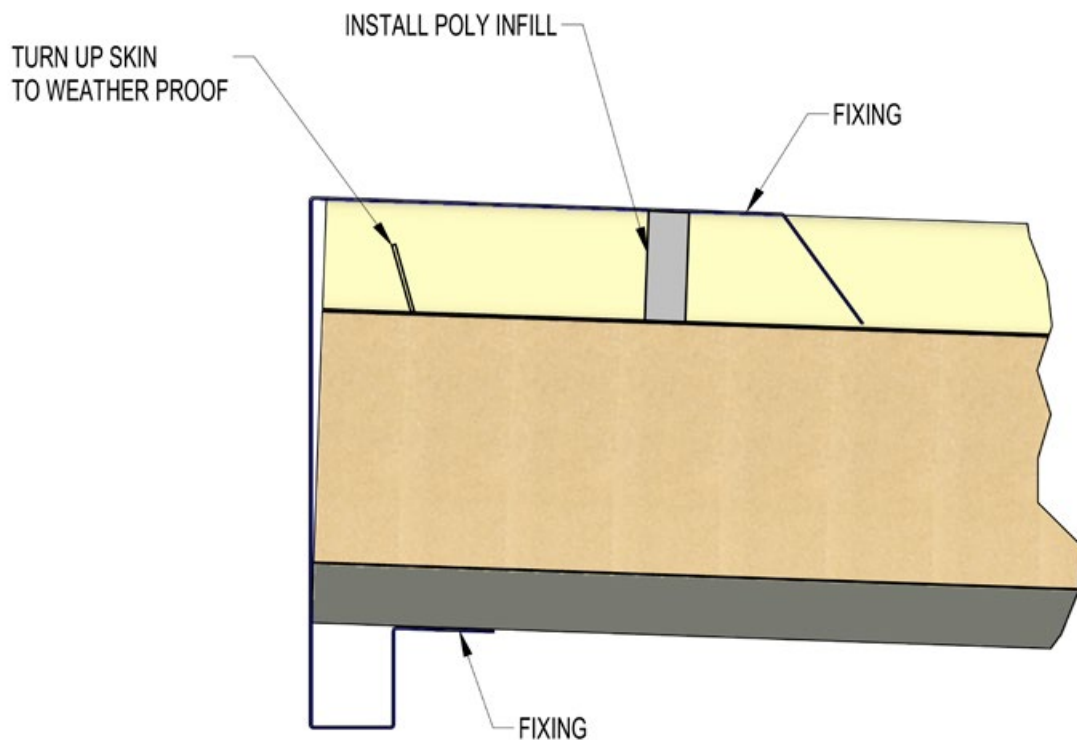
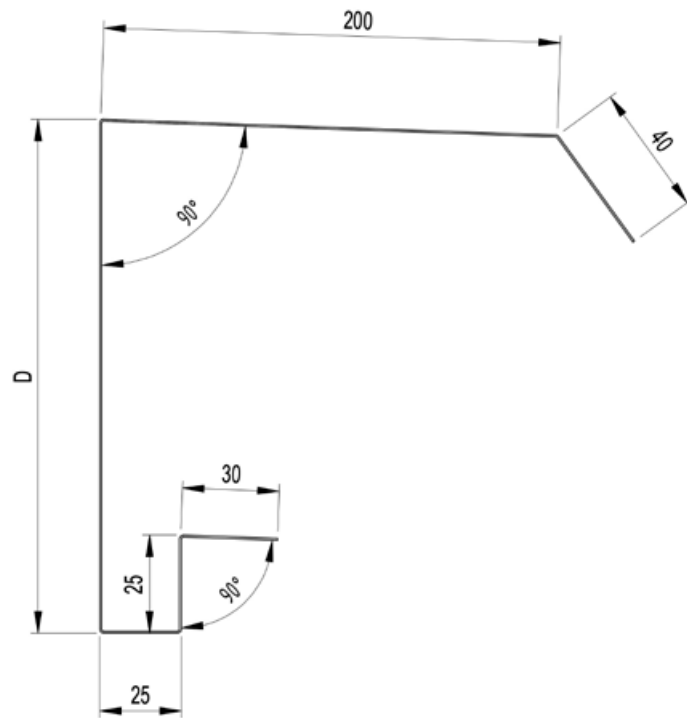

Rear Barge Capping Assembly Detail

15. INSTALLATION - FLASHINGS

DeltaTrimCorro™

DeltaTrimCorro Fascia Flashing

MATERIAL: 0.55mm G300

THICKNESS	D
75mm	92
100mm	117
125mm	142
150mm	167
175mm	192
200mm	217

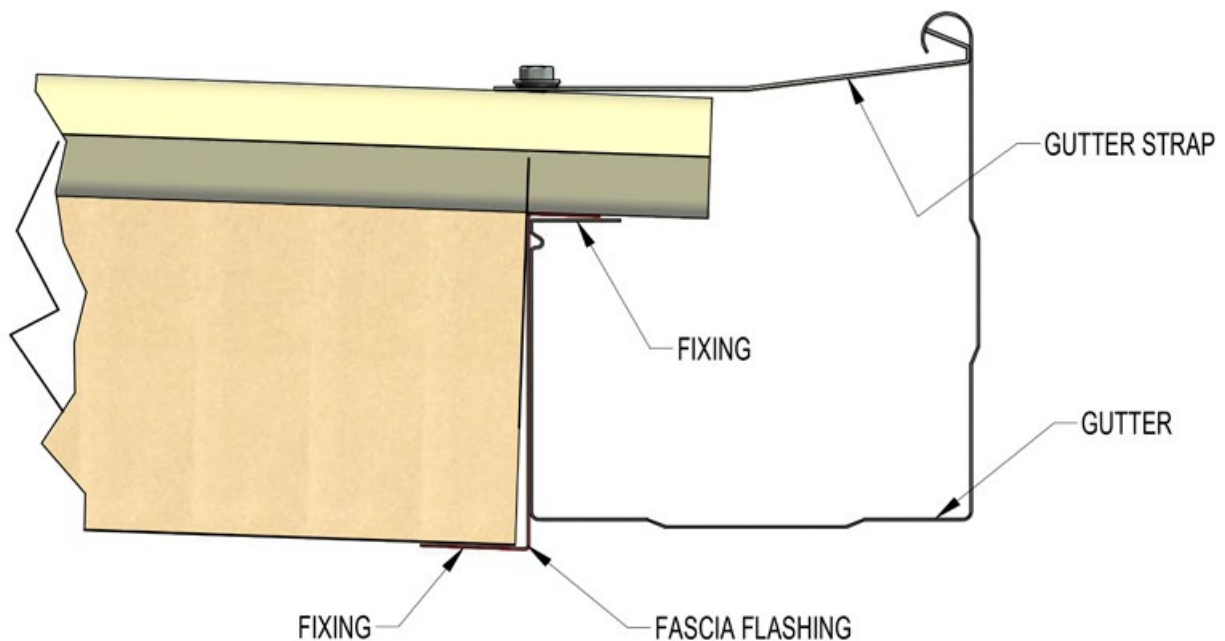
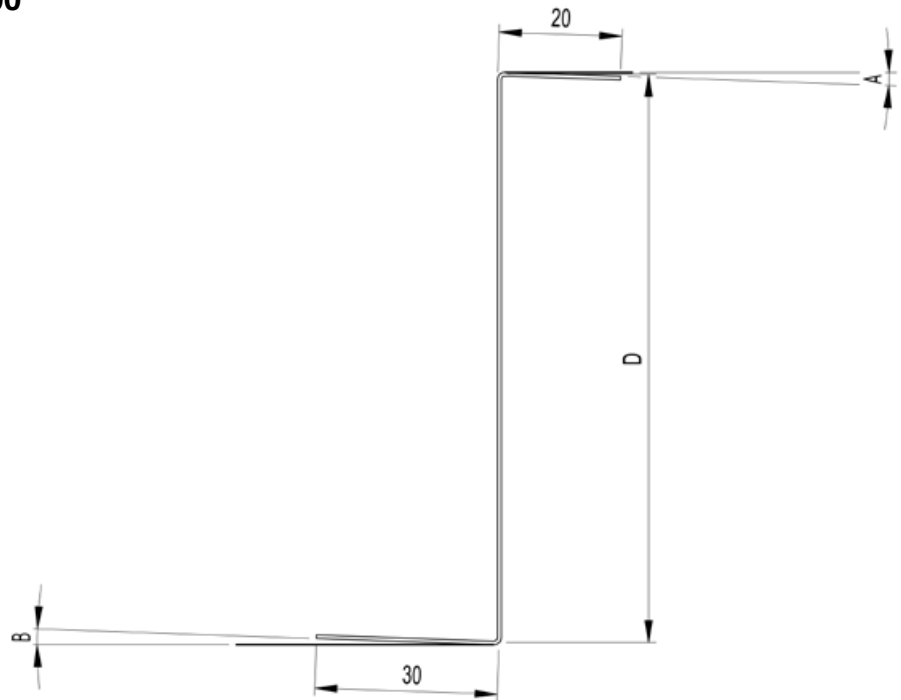

Fascia Flashing Assembly Detail

Flashing must be fitted in accordance with the relevant standard.

15. INSTALLATION - FLASHINGS

DeltaTrimCorro™

DeltaTrimCorro Fascia Flashing with Drip Guard

MATERIAL: 0.55mm G300

THICKNESS	D
75mm	123
100mm	148
125mm	173
150mm	198
175mm	223
200mm	248

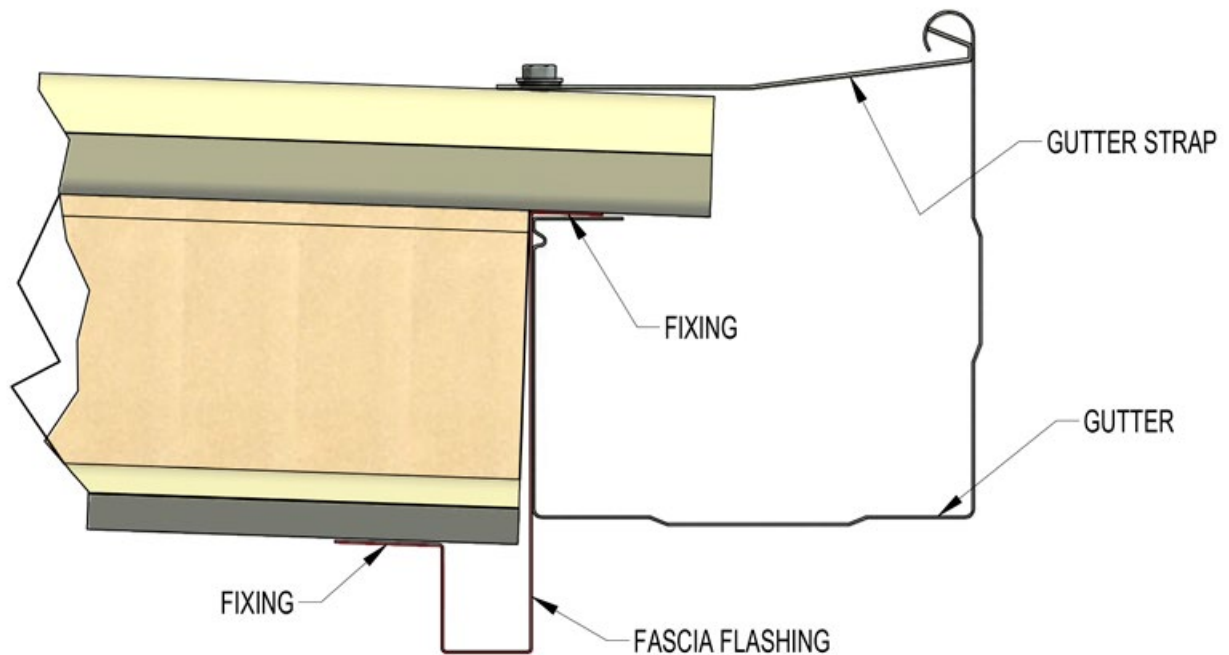
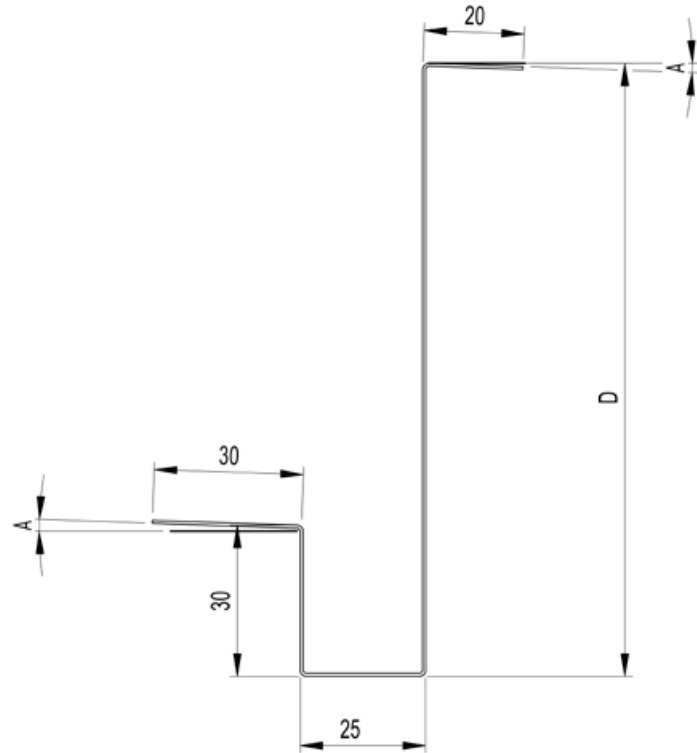

Fascia Flashing Assembly Detail

Flashing must be fitted in accordance with the relevant standard.

16. INSTALLATION OF SERVICES AND ACCESSORIES

Service Duct

All Delta Panels™ insulated building panels have a service duct profiled into the insulated core. The surface duct is designed to accept a conduit and is upward facing to ensure that the conduit does not roll out when the panel is being installed

It is recommended that all fixtures fitted to the underneath skin of the panel are located as close to a panel joint as possible.

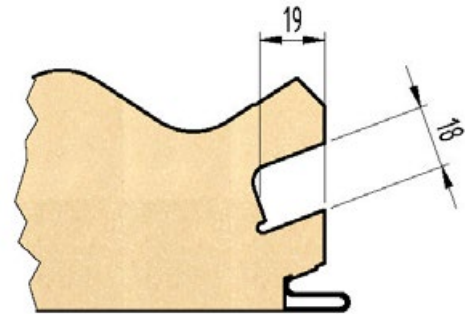

Recessed Lighting

Delta Panels™ have a range of low voltage LED recess lighting, DeltaLowProfile™ Light, specifically designed to be installed into insulated panels.

Recess cut-outs are required to be made into the underneath of the panel.

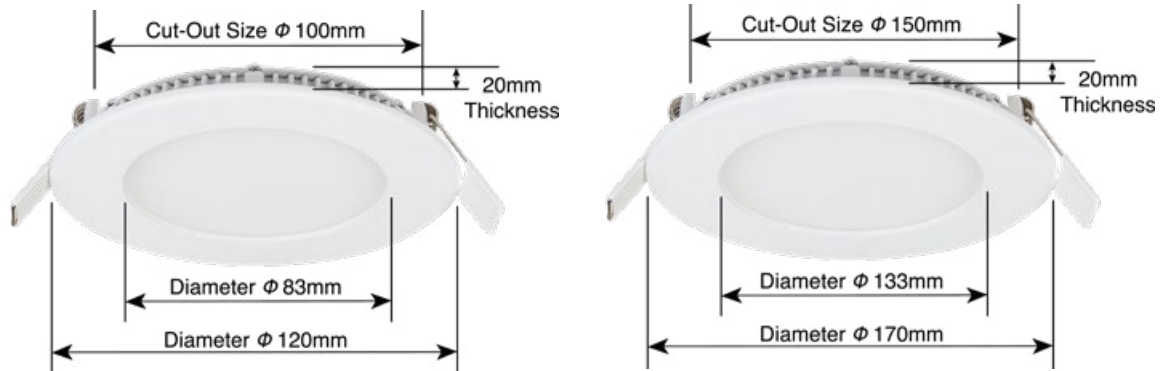

All electrical cabling is double insulated but the use of electrical conduit is still recommended

For ease of future access it is recommended to house the driver either behind the light fitting or in the eave/ridge capping.

A qualified electrician is required to install the GPO outlets for the low voltage lights.

Detailed procedures are outlined in the DeltaLowProfile™ Safety & Installation Manual, which is supplied with the lights and is also available online at www.deltapanel.com

16. INSTALLATION OF SERVICES AND ACCESSORIES

Panel Lighting

Delta Panels™ supply a range of low voltage LED panel lighting, DeltaPanelLight™, specifically designed to be installed into the underneath skin of insulated panels.

There is no requirement for cut-outs into the underneath of the panel, as frame is directly attached onto the underneath surface of the panel.

All electrical cabling is double insulated but the use of electrical conduit is still recommended

For ease of future access it is recommended to house the driver behind the light panel within the support frame.

A qualified electrician is required to install the GPO outlets for the low voltage LED panel lights.

Detailed procedures are outlined in the DeltaPanelLight™ Safety & Installation Manual, which is supplied with the lights and is also available online at www.deltapanel.com



16. INSTALLATION OF SERVICES AND ACCESSORIES

Ceiling Fans

To mount ceiling fans to insulated panels it is necessary to use a range of specifically designed brackets which ensure that the weight of the fan is spread over the whole of the top skin of the panel. Ridge fixing is highly recommended.

The brackets are designed to cater for a dead-load weight of 30 kgs, they're to be attached to the mounting brackets that come as part of the ceiling fan kit.

All electrical work must be carried out by a Licensed Electrician.

BRACKET INSTALLATION DETAILS - DELTAORB™

END VIEW

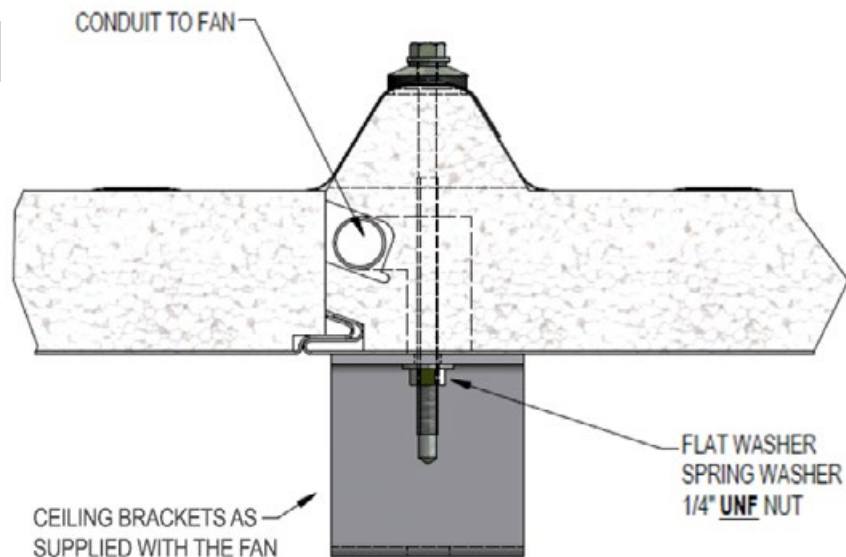

SIDE VIEW

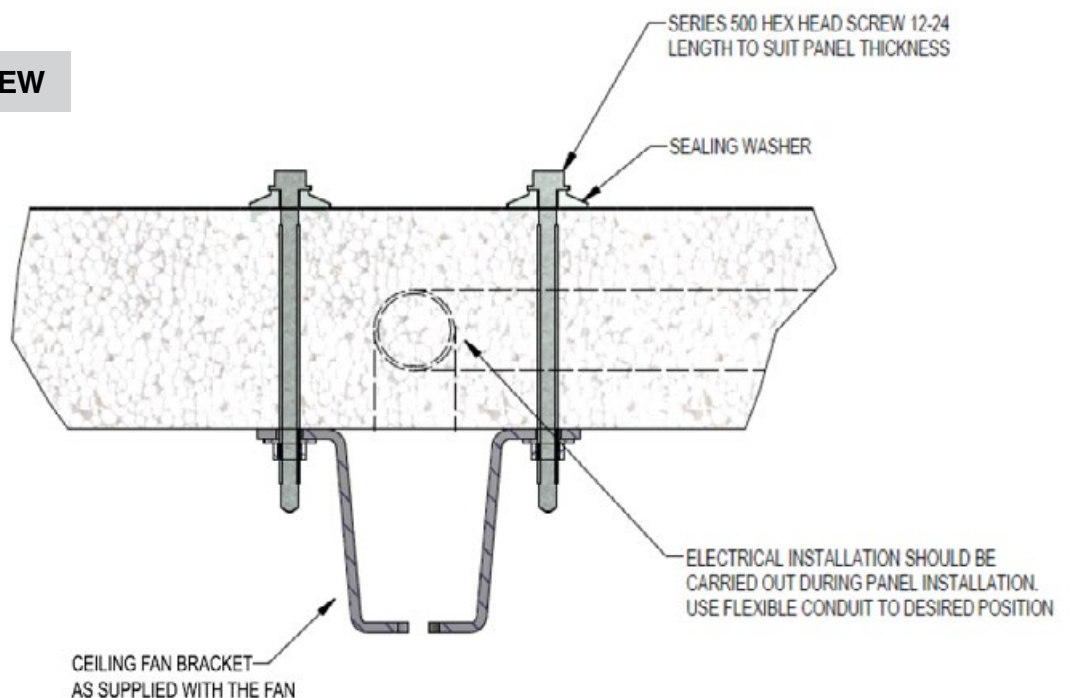

16. INSTALLATION OF SERVICES AND ACCESSORIES

BRACKET INSTALLATION DETAILS - DELTATRIM™

END VIEW

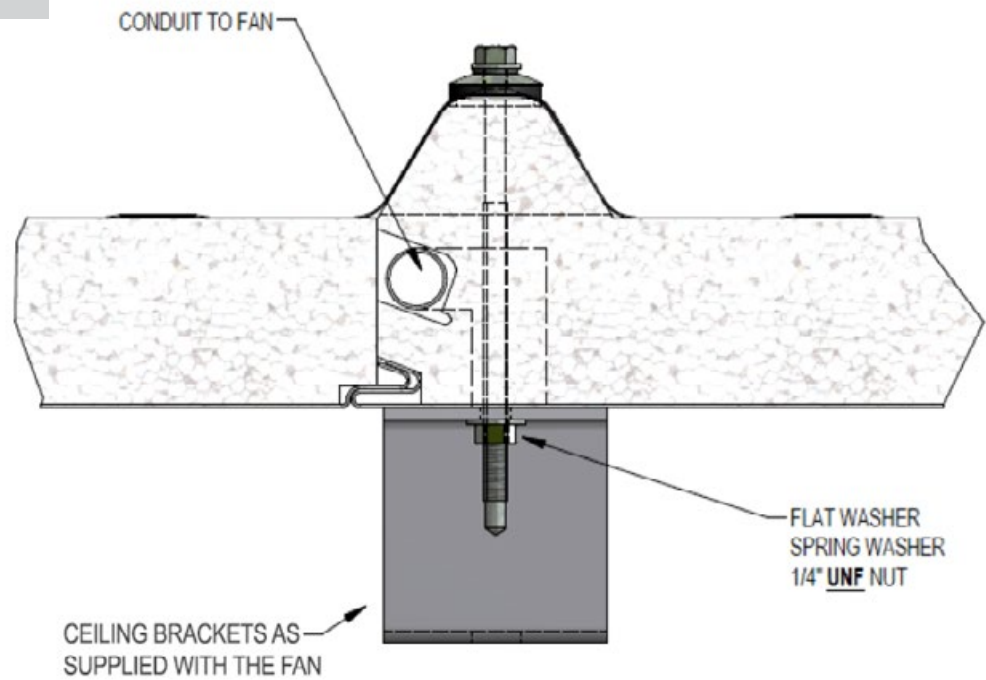

SIDE VIEW

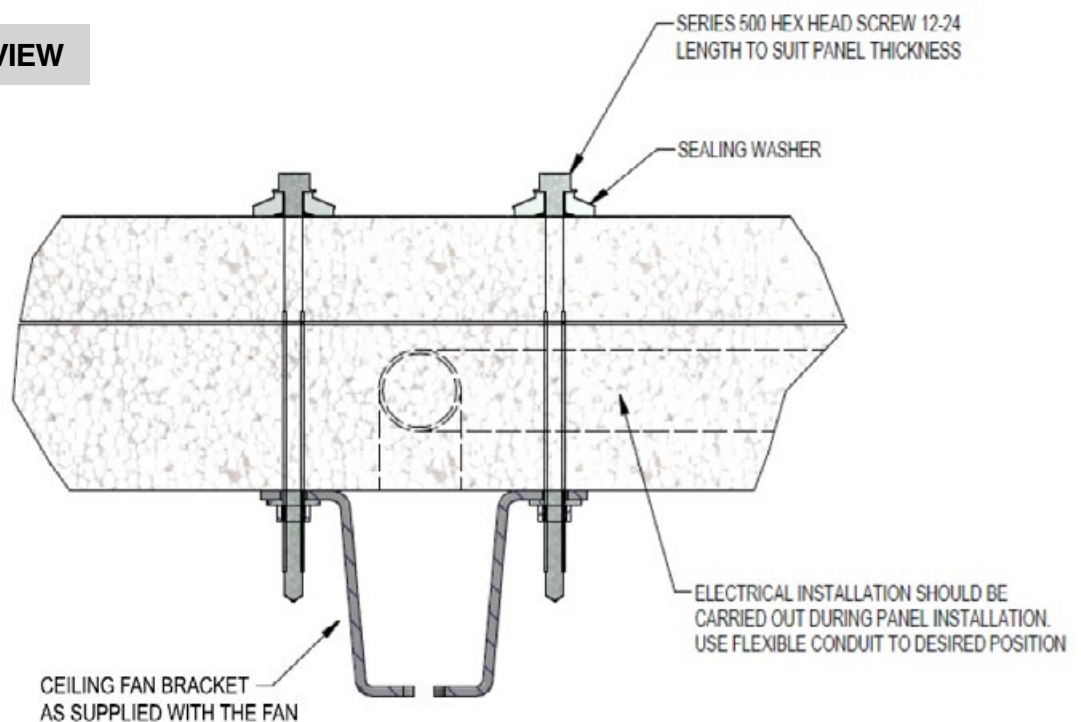

16. INSTALLATION OF SERVICES AND ACCESSORIES

All Purpose Service Support Bracket

To fix an all purpose support bracket to insulated panels it is necessary to ensure that the weight is spread over the whole of the top skin of the panel. Therefore a through-fastening arrangement is required. The all purpose service bracket is designed to cater for a dead-load weight of 30 kgs.

Ridge fixing as close as possible to the panel join is highly recommended.

ALL PURPOSE SERVICE SUPPORT BRACKET

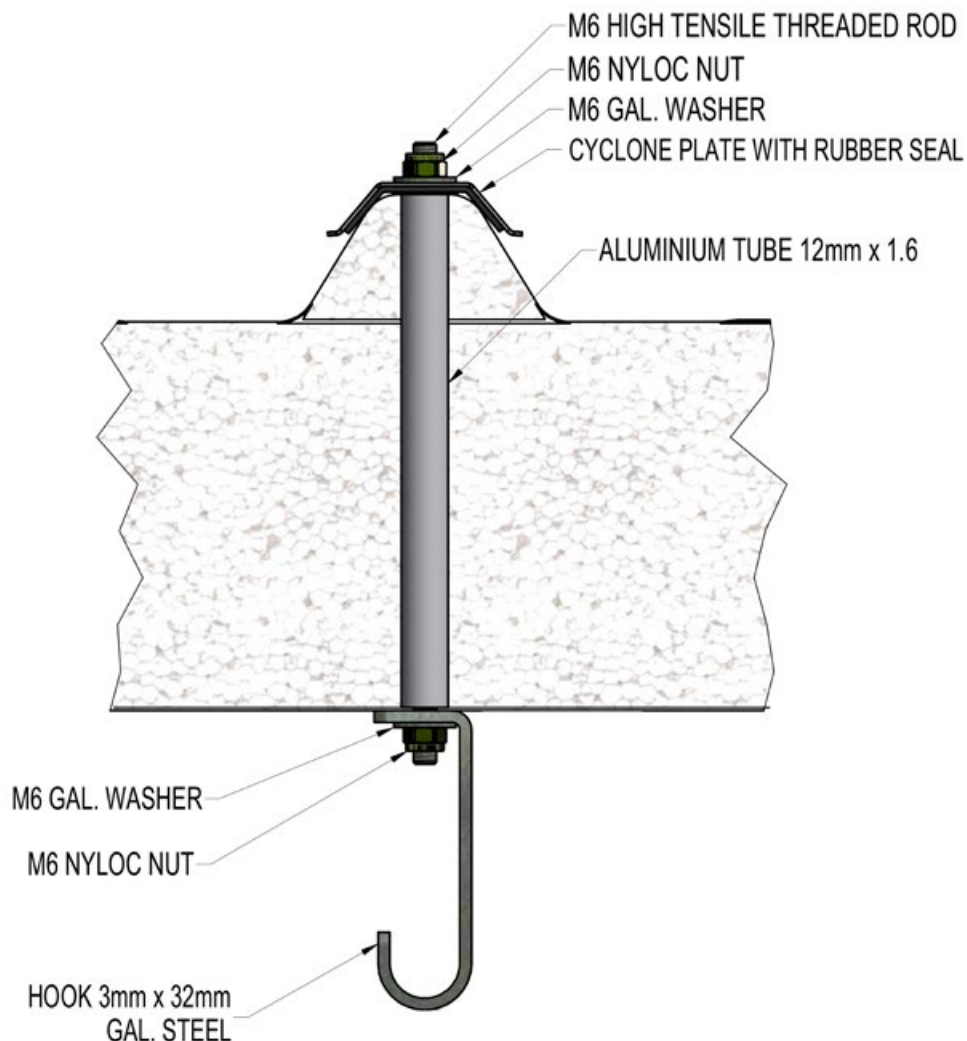

16. INSTALLATION OF SERVICES AND ACCESSORIES

PV Solar Panel Connection Brackets

Prior to the installation of PV Solar Panels to the roof please refer to the Dead Load Table to ensure that the roof, as installed, is designed for the additionally imposed load.

To mount PV Solar Panels fans to insulated panels it is necessary to use a range of specifically designed brackets which ensure that the weight of the solar panels is evenly spread over the whole roof area.

The mounting brackets are designed to be Ridge fixed and will accept the mounting plates that come with the PV Solar panels.

PV Solar Panels can be installed either in portrait or landscape orientation. The brackets are designed to cater for both of these options.

Detailed procedures are outlined in the Delta Panels™ Photovoltaic (PV) Solar Panels Manual, which is available online at www.deltapanel.com

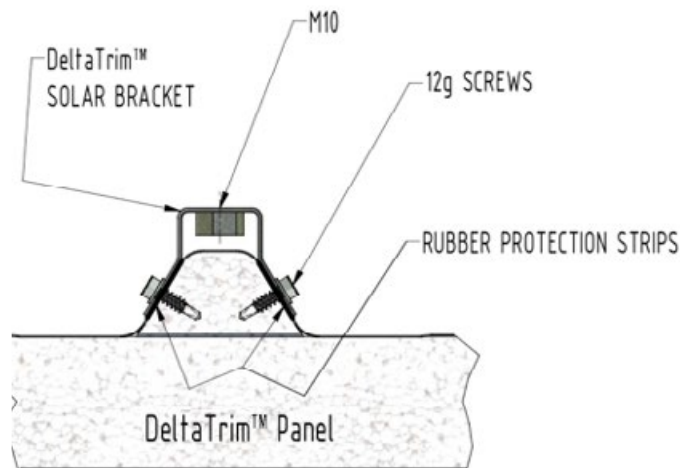

Bracket Fixing Details - DeltaTrim™ Panel

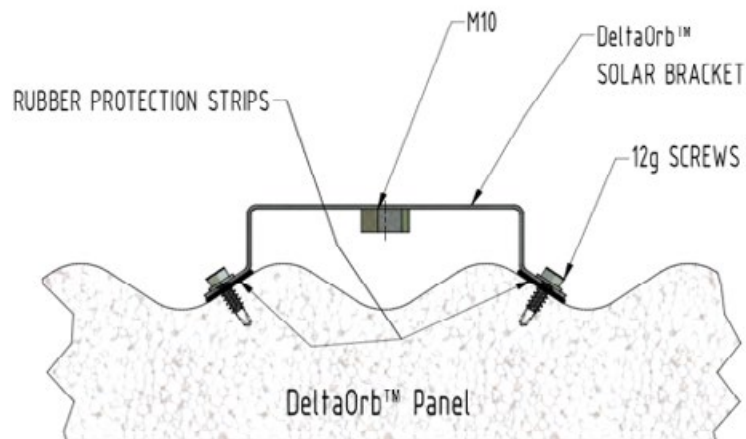

Bracket Fixing Details - DeltaOrb™ Panel

16. INSTALLATION OF SERVICES AND ACCESSORIES

Portrait Solar Panel Fixing Requirements

All brackets to be screwed with 12g class 4 screws with seal.

Wind Class	Limit State Design Pressure (kPa)	Brackets / Panel @ 250mm crs	Screws / Brackets @ 250mm crs	Brackets / Panel @ 500mm crs	Screws / Brackets @ 500mm crs
N2	2.16	6	4	4	4
N3	3.32	6	4	4	4
N4	4.97	6	4	4	4
N5	7.14	6	6	4	8
C1	3.79	6	4	4	4
C2	5.64	6	6	4	8
C3	8.11	6	6	4	10
C4	11.04	6	10	N/A	N/A

Landscape Solar Panel Fixing Requirements

All brackets to be screwed with 12g class 4 screws with seal.

Wind Class	Limit State Design Pressure (kPa)	Brackets / Panel @ 250mm crs	Screws / Brackets @ 250mm crs	Brackets / Panel @ 500mm crs	Screws / Brackets @ 500mm crs
N2	2.16	10	4	6	4
N3	3.32	10	4	6	4
N4	4.97	10	4	6	4
N5	7.14	10	4	6	4
C1	3.79	10	4	6	4
C2	5.64	10	4	6	4
C3	8.11	10	4	6	4
C4	11.04	10	4	6	6

Dead Load - Kgs/m²

Span (mm)	Panel Thickness						
	50mm	75mm	100mm	125mm	150mm	175mm	200mm
3000	15.00	17.50	20.00	22.50	25.00	27.50	30.00
6000		12.50	15.00	20.00	22.50	25.00	27.50
8000			10.00	12.50	18.50	20.00	25.00
10000					15.00	17.50	15.00
12000							10.00

1. Published figures are a maximum, for an evenly distributed load
2. No load allowed on the overhangs
3. For any loads and spans not shown in this table specific engineering will be required

16. INSTALLATION OF SERVICES AND ACCESSORIES

Plasterboard Attachment

The plasterboard attachment bracket is designed to carry a dead-load of 15kgs/m², so prior to the attachment of plasterboard to the underneath side of an insulated panel roof, it's essential that engineering calculations are carried out to ensure that the roof as installed is designed for the additional load that will be imposed by the additional equipment.

To mount plasterboard fixing brackets to insulated panels it is necessary to identify which way that the battens will run. As the battens can either run parallel to the panel join or across ways.

Insulated Roof Plasterboard Attachment

OPTION A

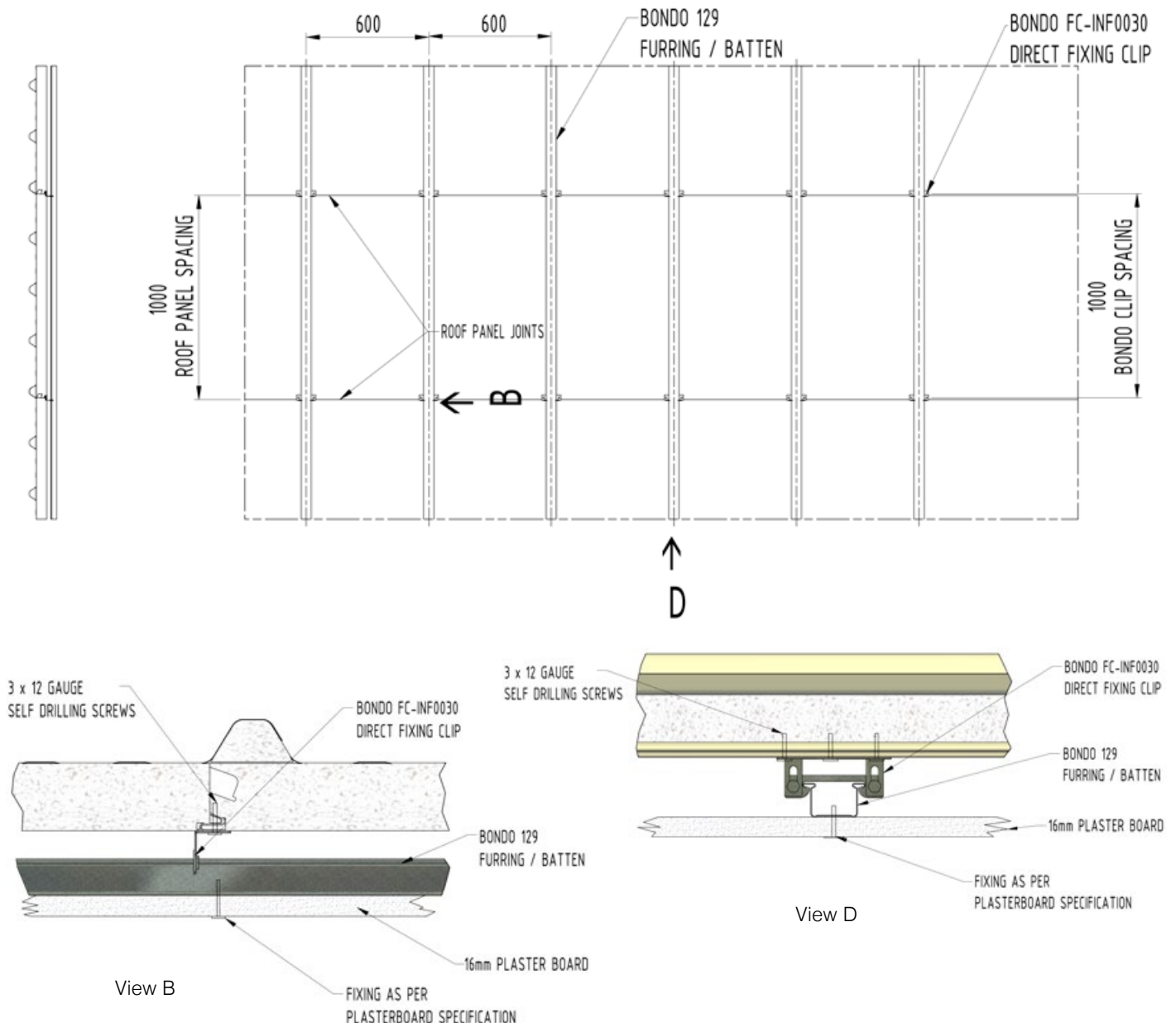

16. INSTALLATION OF SERVICES AND ACCESSORIES

Insulated Roof Plasterboard Attachment

OPTION B

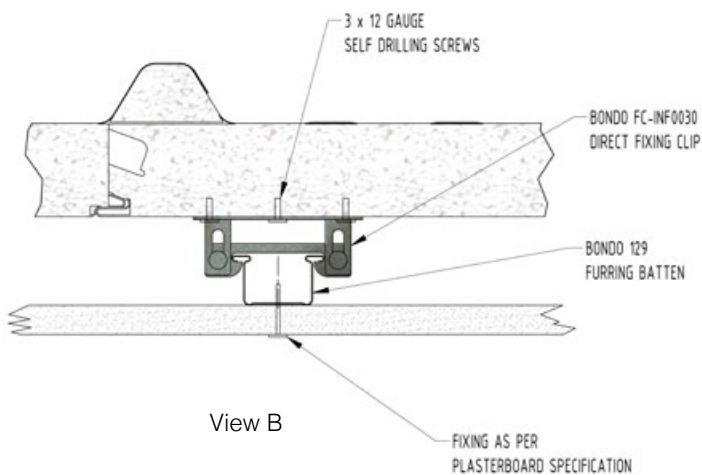
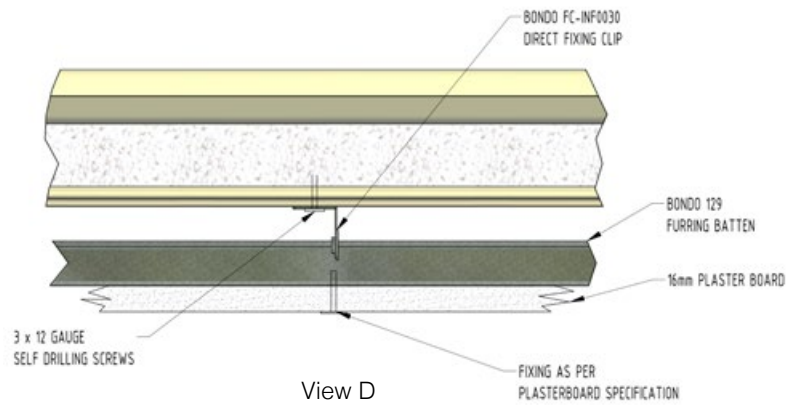
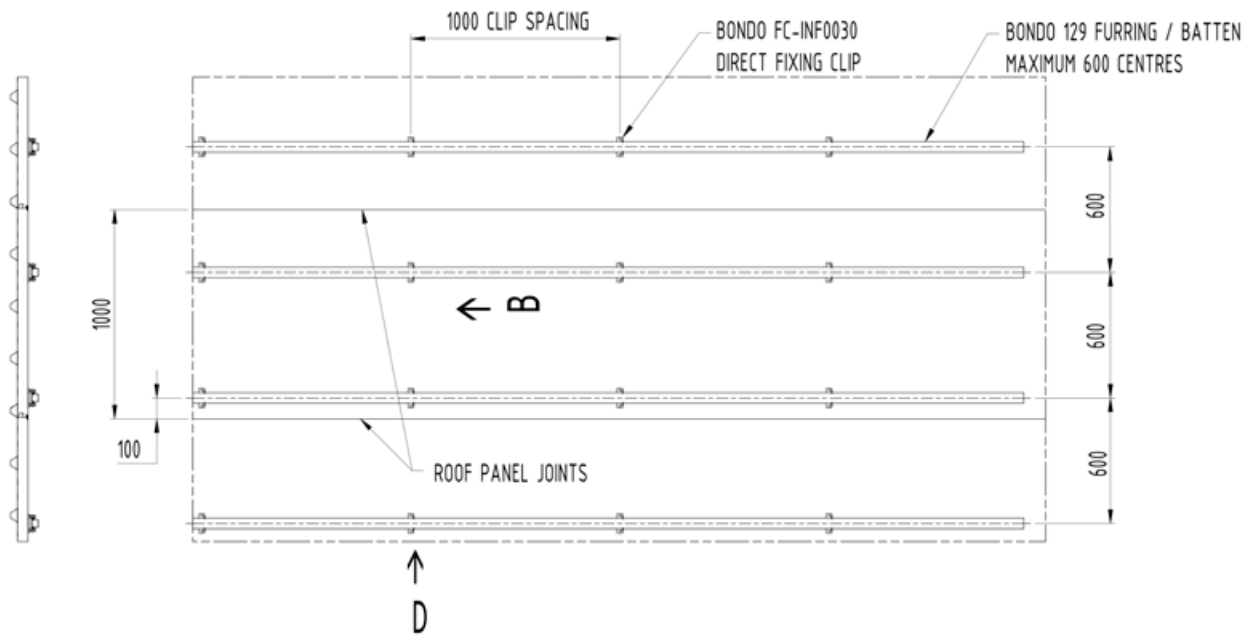

17. REFERENCE LIBRARY

Delta Panels™ Pty Ltd is committed to an ongoing programme of product research and development and reserves the right to update and amend information without prior notice. Reasonable care has been taken to ensure that all published information is correct and accurately reflects the properties of our products and their design applications at the time of publication. However these are a general guide only, it is the customers responsibility to ensure that all products and their stated applications are fit for purpose and complies with all relevant statutory requirements.

To ensure that you keep abreast of all updates in our product range, all current reference material are available on our web page for downloading.

- Acoustic Property Information
- CodeMark Australia Certificate – CM40309
- Core Material Comparisons
- Engineering Module A – Awnings, Patios & Carports Engineering & Construction Manual
- Engineering Module B – Awnings, Patios & Carports Pre-Engineered Kits
- Engineering Module C – Gable Roofing Engineering & Construction Manual
- Engineering – Walls
- Engineering –Bottom & Top Connections in Cyclonic Regions
- Engineering – Racking Tests
- Engineering – Non-Combustible Certification – Mineral Wool Panels
- Factory Mutual Certifications – FM4880, FM4881 & FM4471
- Fire Test - Expanded Polystyrene – Fire Retardant (EPS-FR) BAL 29/40 – Branz
- Fire Test - Polyisocyanurate (PIR) BAL 29/40 – Branz
- Fire Test - Polyisocyanurate (PIR) Group 1 – ISO 9705 - Branz
- Fire Test - Thermosetting Phenolic Composite (TPC) Group 1 – ISO 9705 - Branz
- Fire Test - Expanded Polystyrene – Fire Retardant (EPS-FR) -AS 1530.3-1999 - AWTA
- Fire Test - Polyisocyanurate (PIR) - AS 1530.3-1999 - AWTA
- Fire Test - Thermosetting Phenolic Composite (TPC) -AS 1530.3-1999 - AWTA
- Fire Test - Mineral Wool (MW)) - AS 1530.3-1999 - AWTA
- Fire Test - Mineral Wool (MW)) – FRL - Branz
- Flashings – Recommended installation
- Handling & Installation Manual – Roofing Systems
- Lighting – DeltaLowProfile™ – Installation Guideline
- Lighting – DeltaPanel Light™ – Installation Guideline
- Lighting – DeltaLum™ – Installation Guideline
- Product Catalogue – Delta Panels™
- Product Catalogue – DeltaFireX™
- Product Catalogue – DeltaMax™
- Product Catalogue – DeltaPanel™ Light
- Product Catalogue – DeltaLowProfile™
- Product Catalogue – DeltaLum™
- Product Catalogue – DeltaSingle™
- Product Catalogue – DeltaSkylights™
- Product Catalogue – DeltaXtremeBeam™
- Product Catalogue – Guide to PV Solar Panel installation
- Product Catalogue – Timber Posts & Beams
- Product Data Sheets – Expanded Polystyrene – Fire Retardant (EPS-FR) Roof & Wall Panels
- Product Data Sheets – Polyisocyanurate (PIR) Roof & Wall Panels
- Product Data Sheets – Thermosetting Phenolic Composite (TPC) Roof & Wall Panels
- Product Data Sheets – Mineral Wool (MW) Roof & Wall Panels
- Safety Data Sheets – EPS-FR, PIR, TPC & MW
- Warranty – Walls, Roof, Beams & Lighting Systems
- Wind Speed Calculation Guide

DeltaMax™, DeltaTrim™, DeltaOrb™, DeltaCorroCorro™, DeltaTrimTrim™, DeltaTrimCorro™, DeltaSingle™, DeltaBeam™, DeltaXtremeBeam™ & DeltaLowProfile™ are all trademarks of Delta Panels™ Pty Ltd





Delta Panels™ Pty Ltd is committed to an ongoing programme of product research and development and reserves the right to update and amend information without prior notice. Reasonable care has been taken to ensure that all published information is correct and accurately reflects the properties of our products and their design applications at the time of publication. However these are a general guide only, it is the customers responsibility to ensure that all products and their stated applications are fit for purpose and complies with all relevant statutory requirements. To ensure that you keep abreast of all updates in our product range, all current reference material are available on our web page for downloading.

All information contained within this document is subject to Copyright and may not be copied without the express permission of Delta Panels™ Pty Ltd.

Delta Panels™, DeltaSpan™, DeltaTrim™, DeltaOrb™, DeltaCorroCorro™, DeltaTrimTrim™, DeltaTrimCorro™, DeltaLowProfile™ & DeltaPanelLight™ are registered trademarks of Delta Panels™ Pty Ltd.